

Atlas Copco

Oil-injected rotary screw compressors

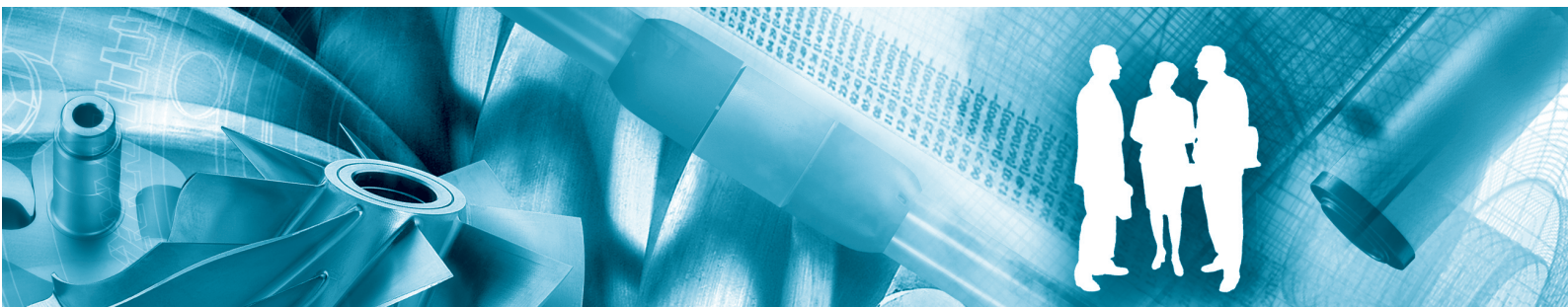

GA 15 VSD, GA 18 VSD, GA 22 VSD, GA 26 VSD, GA 30 VSD

Parts list



Atlas Copco

Oil-injected rotary screw compressors

GA 15 VSD, GA 18 VSD, GA 22 VSD, GA 26 VSD,
GA 30 VSD

From following serial No. onwards: API 427 000

Parts list

- Copyright, Atlas Copco Airpower n.v., Antwerp, Belgium.
Any unauthorized use or copying of the contents or any part thereof is prohibited.
This applies in particular to trademarks, model denominations, part numbers and drawings.
- **Use only authorized parts.** Any damage or malfunction caused by the use of unauthorized parts is not covered by Warranty or Product Liability.

2012 - 11

No. 2930 7080 13
Replaces No. 2930 7080 12

www.atlascopco.com



en - INSTRUCTIONS FOR USE

1 ORDERING PARTS

Always specify the part number, the name and quantity of the required items, as well as the type and serial number of the machine.

Pages marked with Service symbol -  contain parts of Service kit(s). For complete contents of the kit see chapter "1 - Service kits".

2 COLUMN INFORMATION

Ref. - Reference number: links a specific listed part to the drawing. Only parts with a reference number are shown in the drawing. Parts in the drawing without a reference number are simply there to illustrate the assembly.

Part number - Part number: if no part number is specified, the component is not available as a spare part. A line shown in bold is an assembly. A part of which the number is followed by a black dot is comprised in the bold printed assembly right above.

"<<< >>>" Directs to another list with the same title as the "Name".

When the part number of the specific parts is placed below the "Ref./Name" line a choice must be made upon the type/version of the machine.

Qty - Quantity: indicates the number of parts in connection with the corresponding reference number. „AR“ means „As required“: quantity or number to be determined.

Name - Part name: translations of the English names can be found in document "Glossary of part names".

Remarks - Extra information about the part.

A series of letters can indicate that a particular part has been certified by the specified authorized body, in accordance with the codes or rules of the list.

Measurements are given in millimeters.

bg - ИНСТРУКЦИИ ЗА ИЗПОЛЗВАНЕ

1 ЗАЯВЯВАНЕ НА РЕЗЕРВНИ ЧАСТИ

Винаги указвайте номера на частта, наименованието и необходимото количество от артикула, както и модела и серийния номер на машината.

Страниците, маркирани със символ за сервиз - , съдържат части от Сервизен комплект(и). За пълното съдържание на комплекта вж. глава "1 - Service kits" (1 - Сервизни комплекти).

2 ЗНАЧЕНИЕ НА КОЛОНИТЕ

Ref. - Цифрово обозначение: връзка с чертежа за определена част от спецификацията. На чертежа са показани само детайли с цифрово обозначение. Детайлите без цифрово обозначение в чертежа са показани само за прегледност на сглобената единица.

Part number - Номер на частта: ако не е указан такъв, детайлът не се предлага като резервна част. Удебелена линия означава сглобена единица. Част, чийто номер е последван от черна точка, се съдържа в сглобената единица, отпечатана точно отгоре с получер шрифт.

"<<< >>>" е указател към друга спецификация със същото наименование като "Name".

Когато номерът на частта на указания детайл е разположен под реда "Ref./Name", трябва да се направи избор съобразно модела/версията на машината.

Qty - Количество: указва броя детайли, свързани със съответното цифрово обозначение. "Заявка" означава "По заявка": количество или бройка за доуточняване.

Name - Наименование на частта: преводите на английските наименования могат да бъдат намерени в документа "Речник на наименованията на частите".

Remarks - Допълнителна информация за частта.

Поредица от букви може да указва, че определен детайл е сертифициран от посочения упълномощен орган за съответствие с параметрите или правилата в спецификацията.

Всички стойности са дадени в милиметри.

br - INSTRUÇÕES DE USO

1 ENCOMENDANDO PEÇAS

Sempre especifique o número da peça, o nome e a quantidade dos itens necessários, assim como o tipo e o número de série da máquina.

Páginas marcadas com o símbolo Serviço -  contém peças do(s) Kit(s) de serviço. Para conhecer o conteúdo completo do kit, consulte o capítulo "1 - Service kits" (1 - Kits de serviço).

2 INFORMAÇÕES SOBRE AS COLUNAS

Ref. - Número de referência: indica onde está uma peça específica listada no desenho. Somente peças com número de referência são mostradas no desenho. As peças no desenho que não têm um número de referência destinam-se simplesmente a ilustrar o conjunto.

Part number - Número da peça: se nenhum número de peça estiver especificado, o componente não está disponível como peça sobressalente. Uma linha mostrada em negrito é um conjunto. Uma peça cujo número seja seguido por um ponto preto faz parte do conjunto impresso em negrito imediatamente acima dela.

O símbolo "<<< >>>" direciona para outra lista com o mesmo título, como "Name" (Nome).

Quando o número de peça específico é colocado abaixo da linha "Ref./Name" (Ref. / Nome), é preciso escolher o tipo/versão da máquina.

Qty - Quantidade: indica o número de peças e os números de referência correspondentes. "AR" significa "As required" (Conforme solicitado): a quantidade ou o número a ser determinado.

Name - Nome da peça: as traduções dos nomes em inglês podem ser encontradas no documento "Glossary of part names" (Glossário de nomes de peças).

Remarks - Observações - Informações extras sobre a peça.

Uma série de letras pode indicar que uma determinada peça é certificada pelo órgão autorizado específico, de acordo com os códigos ou as regras da lista.

As medidas são fornecidas em milímetros.

cs - NÁVOD K POUŽITÍ

1 OBJEDNÁNÍ DÍLŮ

Vždy uveďte přesné číslo dílu, název a množství požadovaných položek, a také typ a sériové číslo stroje.

Stránky označené symbolem servisu -  obsahují součásti servisní sady (servisních sad). Kompletní obsah sady naleznete v kapitole "1 - Service kits" (1, Servisní sady).

2 INFORMACE VE SLOUPCÍCH

Ref. - Referenční číslo: odkazuje díl uvedený v seznamu k místu ve výkresu. Ve výkresu jsou uvedeny pouze díly s referenčním číslem. Díly bez referenčního čísla, které jsou ve výkresu uvedeny, slouží pouze jako ilustrace.

Part number - Číslo dílu: pokud není uvedeno číslo dílu, component se jako náhradní díl nedodává. Řádek tučně je sestava. Díl, jehož číslo je následováno černou tečkou, je součástí sestavy, jejíž název je vtištěn tučně výše.

"<<< >>>" vede na další seznam se stejným názvem, jaký je uveden v poli „Name“ (Název dílu).

Pokud je pod řádkem „Ref./Name“ umístěno číslo dílu konkrétního dílu, musí být proveden výběr typu/verze stroje.

Qty - Množství: uvádí počet dílů spojených s příslušným referenčním číslem. „AR“ znamená „As required“ (podle požadavků): množství nebo číslo, které má být určeno.

Name - Název dílu: překlad anglického názvu lze najít v dokumentu „Rejstřík názvů dílů“.

Remarks - Doplnkové informace k dílu.

Série písmen může označovat, že určitý díl byl certifikován autorizovanou osobou v souladu s kódy a pravidly seznamu.

Rozměry jsou uvedeny v milimetrech.

da - ANVENDELSESIKSTRUKTIONER

1 BESTILLING AF RESERVEDELE

Angiv altid reservedelsnummer, navn og antal for de dele, du ønsker, samt maskinens typebetegnelse og serienummer.

Sider markeret med servicesymbolet -  " indeholder dele af service-kittet(ene). For et samlet overblik over kittets indhold, se kapitel "1 - Service kits"(1 - Service kits).

2 FORKLARING TIL SPALTER

Ref. - Referencenummer: knytter en specifik del på listen til tegningen. På tegningen vises kun reservedele, som har et referencenummer. Reservedele på tegningen, som ikke har et referencenummer, er medtaget for illustrationens skyld.

Part number. - Reservedelsnummer: hvis der ikke er angivet noget reservedelsnummer, fås den pågældende komponent ikke som reservedel. En linje, som vises med fed skrift, er en samling af dele. En reservedel, hvor nummeret er efterfulgt af en sort prik, er en af de dele, der indgår i samlingen af dele, som vises med fed skrift ovenover. "<<< >>>" henviser til en anden liste med samme titel som "Name".

Når den specifikke reservedelsnummer placeres under linjen "Ref./Name", skal du vælge type/version for maskinen.

Qty - Antal: angiver antallet af reservedele, der indgår i det tilsvarende referencenummer. "AR" betyder "As required" (som krævet): mængde eller antal skal bestemmes.

Name - Reservedelsnavn: oversættelse af de engelske navne kan findes i dokumentet "Liste over reservedelsnavne".

Remarks - Ekstra information om reservedelen.

En bogstavrække kan angive, at en bestemt reservedel er blevet certificeret af det pågældende godkendende organ, i henhold til standarderne på listen.

Alle mål er angivet i millimeter.

de - BEDIENUNGSANWEISUNG

1 BESTELLEN VON TEILEN

Immer Teilenummer, Bezeichnung und Anzahl der erforderlichen Teile sowie Typ und Seriennummer der Maschine angeben.

Seiten mit dem Servicesymbol -  " enthalten Teile von Service-Kit(s). Informationen zum vollständigen Inhalt des Kits finden Sie im Kapitel „1 - Service kits“ (1 - Service-Kits).

2 ERLÄUTERUNG DER SPALTEN

Ref. - Referenznummer: Querverweis zwischen einem aufgeführten Teil und der Zeichnung. In der Zeichnung sind nur Teile mit einer Referenznummer abgebildet. Abgebildete Teile ohne Referenznummer dienen lediglich der Darstellung der Baugruppe.

Part number - Teilenummer: Falls keine Teilenummer angegeben ist, ist das Bauteil nicht als Ersatzteil lieferbar. Baugruppen sind fett hervorgehoben. Wenn sich hinter einer Teilenummer ein schwarzer Punkt befindet, gehört dieses Teil zur darüber stehenden Baugruppe.

"<<< >>>" bedeutet, daß Sie eine andere Liste nachschlagen müssen.

Steht die Teilnummer unter der Ref./Name Zeile, so muß eine Wahl gemacht werden je nach Typ/Ausführung der Maschine.

Qty - Anzahl: Gib die Anzahl der Teile in Bezug auf die entsprechende Referenznummer an. „AR“ steht für „As required“ (nach Bedarf), die gewünschte Anzahl muss angegeben werden.

Name - Teilebezeichnung: Eine Übersetzung der englischen Bezeichnungen finden Sie im Dokument "Glossary of part names" (Glossar Teilebezeichnungen).

Remarks - Zusätzliche Information zu dem Teil.

Eine Buchstabenfolge weist darauf hin, dass ein bestimmtes Teil durch die angegebene zuständige Stelle gemäß den aufgeführten Normen und Richtlinien zertifiziert wurde.

Abmessungen sind in Millimetern angegeben.

el - ΟΔΗΓΙΕΣ ΧΡΗΣΗΣ

1 ΠΑΡΑΓΓΕΛΙΑ ΑΝΤΑΛΛΑΚΤΙΚΩΝ

Να προσδιορίζετε πάντοτε τον κωδικό είδους, την περιγραφή και την ποσότητα των αιτούμενων ειδών καθώς, επίσης, και τον τύπο και τον αριθμό σειράς του μηχανήματος.

Οι σελίδες που επισημαίνονται με το σύμβολο Σέρβις-  περιέχουν μέρη από Πακέτα ανταλλακτικών συντήρησης. Για το πλήρες περιεχόμενο του πακέτου, ανατρέξτε στο κεφάλαιο "1 - Service kits" (1 - Πακέτα ανταλλακτικών συντήρησης).

2 ΠΛΗΡΟΦΟΡΙΕΣ ΓΙΑ ΤΗ ΣΥΜΠΛΗΡΩΣΗ ΤΩΝ ΣΤΗΛΩΝ

Ref. - Κωδικός αναφοράς: συνδέει ένα συγκεκριμένο λειτουργικό εξάρτημα του καταλόγου με το σχέδιο. Στο σχέδιο εμφανίζονται μόνο εξαρτήματα που διαθέτουν κωδικό αναφοράς. Τα εξαρτήματα του σχεδίου που δε διαθέτουν κωδικό αναφοράς απλώς εμφανίζονται για την πληρέστερη περιγραφή του συγκροτήματος.

Part number - Κωδικός είδους: εάν δεν προσδιορίζεται κωδικός είδους, το εξάρτημα δεν είναι διαθέσιμο ως ανταλλακτικό. Γραμμές που εμφανίζονται με έντονη γραφή αντιστοιχούν σε συγκροτήματα. Ένα εξάρτημα του οποίου ο κωδικός ακολουθείται από μαύρη τελεία περιλαμβάνεται στο αμέσως παραπάνω συγκρότημα που εμφανίζεται με έντονη γραφή.

Το "<<< >>>" αποτελεί αναφορά σε άλλο κατάλογο με τον τίτλο που αναγράφεται στην ένδειξη "Name".

Όταν ο κωδικός είδους του προσδιοριζόμενου εξαρτήματος βρίσκεται κάτω από τη γραμμή "Ref./Name", θα πρέπει να γίνει επιλογή του τύπου/έκδοσης του μηχανήματος.

Qty - Ποσότητα: υποδεικνύει το πλήθος των εξαρτημάτων που ζητούνται από τον αντίστοιχο κωδικό αναφοράς. "AR" σημαίνει "As required" (Σύμφωνα με τις απαιτήσεις): ποσότητα ή πλήθος προς προσδιορισμό.

Name - Περιγραφή είδους: μεταφράσεις των αγγλικών ονομασιών περιέχονται στο έντυπο "Γλωσσάριο εξαρτημάτων".

Remarks - Πρόσθετες πληροφορίες σχετικά με ένα ανταλλακτικό.

Η ύπαρξη μιας σειράς γραμμάτων υποδεικνύει ότι ένα συγκεκριμένο ανταλλακτικό διαθέτει έγκριση από τον αναφερόμενο εξουσιοδοτημένο φορέα, σύμφωνα με τους κώδικες ή τους κανονισμούς του καταλόγου.

Οι διαστάσεις αναφέρονται σε χιλιοστάμετρα.

es - INSTRUCCIONES DE USO

1 PEDIDO DE PIEZAS

Especifique siempre la designación, el nombre y la cantidad de las piezas deseadas, así como el tipo y el número de serie de la máquina.

Las páginas marcadas con el símbolo de Servicio -  " contienen piezas de kit(s) de servicio. Para el contenido completo del kit, vea el capítulo "1 - Service kits" (1 - Kits de servicio).

2 INFORMACIÓN DE LAS COLUMNAS

Ref. - Número de referencia: establece un vínculo entre una pieza específica de la lista y el dibujo. Sólo las piezas con número de referencia aparecen en el dibujo. Las piezas que aparecen sin número de referencia sólo se muestran en el dibujo para ilustrar el conjunto.

Part number - Designación: si no se indica ninguna designación, el componente no se encuentra disponible como pieza de repuesto. Los conjuntos aparecen con una línea en negrita. Las piezas con números seguidos por un punto negro, indican que forman parte del conjunto que aparece en negrita anteriormente.

"<<< >>>" dirige a otra lista con el mismo título que el "Name".

Cuando la designación de una pieza específica está situada debajo de la línea "Ref./Name" se debe elegir el tipo/version de la máquina.

Qty - Cantidad: indica la cantidad de piezas asociadas al número de referencia correspondiente. "AR" significa "As required" (según se requiera): debe determinarse la cantidad o el número.

Name - Nombre de la pieza: las traducciones de los nombres en inglés se encuentran en el documento "Glosario de nombres de piezas".

Remarks - Observaciones: información adicional sobre las piezas.

Una serie de letras puede indicar que una pieza específica ha sido certificada por la entidad autorizada indicada, conforme a los códigos o reglas especificados.

Las dimensiones se expresan en milímetros.

et - KASUTUSJUHISED

1 OSADE TELLIMINE

Määrake alati osa number, vajalike osade nimed ja kogused, samuti masina tüüp ja seerianumber.

Hooldussümboliga tähistatud leheküljed - "🔧" sisaldavad hoolduskomplekti(-de) osi. Komplekti täieliku sisu jaoks vt peatükki "1 - Service kits" (1 - Hoolduskomplektid).

2 VEERUTEAVE

Ref. viitenumber seostab konkreetse nimistus oleva osa vastava joonisega. Joonisel on toodud ainult viitenumbriga osad. Joonisel olevad viitenumbriga osad on mõeldud ainult illustratsioonidena.

Part number: osa number. Kui osa number pole määratud, siis pole see komponent varuosana saadaval. Rasvane joon tähistab seadet. Osa, millele järgneb must punkt, koosneb paremal üleval rasvaselt trükitud koostisest.

„<<< >>>“ viib teise loendini, millel on samasugune pealkiri kui „Nimi“.

Kui osa number või konkreetne osa on paigutatud „Viite“/„Nime“ joone alla, tuleb valida seadme tüüp/version.

Qty: kogus näitab vastava viitenumbriga tähistatud osade arvu. „AR“ tähendab „As required“ (Vastavalt vajadusele); määratletakse kas kogus või number.

Name ehk osa nimi: ingliskeelsete nimede tõlked leiata dokumentid „Osa nimede sõnastik“.

Remarks – osa kohta käiv lisateave.

Tähtede seeria võib näidata, et mingi osa on vastavalt nimekirja koodidele või reeglitele volitatud organist sertifitseeritud.

Mootmed on millimeetrites.

fi - KÄYTTÖOHJEET

1 OSIEN TILAAMINEN

Mainitse aina osan numero, haluttujen osien nimitykset ja määrät, sekä koneen malli ja valmistusnumero.

Huoltosymbolilla - "🔧" merkityillä sivuilla on huoltotarvikesarjojen osia. Katso sarjan täydellinen sisältö luvusta "1 - Service kits" (1 - Huoltotarvikesarjat).

2 SARAKKEIDEN SELITYKSET

Ref. - Viitenumber: Viittaa osaan luettelossa ja piirustuksessa. Vain osat, joilla on viitenumber, näkyvät piirustuksessa. Ilman viitenumeroa piirustuksessa olevien osien tarkoituksena on vain selkeyttää kokonaisuutta.

Part number - Osanumber: Jos osanumeroa ei ole ilmoitettu, osaa ei ole saatavana varaosana. Lihavoituna näkyvä rivi on kokonaisuus. Osa, jonka numeroa seuraa musta piste, sisältyy lähinnä ylhäällä lihavoidulla painettuun tarvikesarjaan.

“<<< >>>” kehottaa katsomaan toista luetteloa, jonka "Name"-otsikko on sama.

Kun tietyn osan osanumero on "Ref."/"Name"-viivan alapuolella, on valittava koneen tyyppi/version.

Qty - Määrä: Ilmoittaa viitenumberoon liittyvien osien määrän. "AR" tarkoittaa "As required" (tarpeen mukaan); irtotavaraa tai määrä on selvitettävä.

Name - Osanimi: englanninkielisten osanimien käännökset löytyvät painotuohteesta Osien nimien sanasto.

Remarks - Lisätietoa osasta.

Kirjainyhdistelmä voi ilmoittaa, että mainittu valtuutettu elin on hyväksynyt osan luettelon koodien tai sääntöjen mukaisesti.

Mitat on annettu millimetreinä.

fr - INSTRUCTIONS D'UTILISATION

1 COMMANDE DE PIÈCES DÉTACHÉES

Précisez toujours le numéro de pièce, la désignation et la quantité de composants souhaitée, ainsi que le type et le numéro de série de la machine.

Les pages sur lesquelles figure le symbole d'entretien - "🔧" traitent de pièces comprises dans un/des kit(s) d'entretien. Pour le contenu complet du kit, voir le chapitre "1 - Service kits" (1 - Kits d'entretien).

2 INFORMATIONS DISPONIBLES DANS LES COLONNES

Ref. - Numéro de référence : se réfère à une pièce particulière dans la liste et le schéma. Seules les pièces auxquelles un numéro de référence a été attribué sont représentées sur le schéma. Les pièces sans numéro de référence sur le schéma sont simplement destinées à compléter l'illustration.

Part number - Numéro de pièce détachée : si aucun numéro de pièce n'est spécifié, le composant n'est pas disponible en tant que pièce détachée. Une ligne qui apparaît en gras correspond à un ensemble. Une pièce dont le numéro est suivi d'un point noir est comprise dans l'ensemble apparaissant en gras juste au-dessus.

“<<< >>>” indique à consulter une autre liste.

Si le numéro de pièce d'une pièces spécifiques est placé au-dessous de la ligne de référence/nom, il faut choisir le type/version de la machine.

Qty - Quantité : indique le nombre de pièces avec le numéro de référence correspondant. « AR » signifie « As required » (comme requis) : il s'agit de la quantité ou du nombre à déterminer.

Name - Désignation de la pièce : la traduction des désignations anglaises est disponible dans le document "Glossary of part names" (Glossaire des désignations des pièces).

Remarks - Remarques : informations supplémentaires concernant la pièce.

Une série de lettres peut indiquer qu'une pièce spécifique a été certifiée par l'organisme autorisé mentionné, conformément aux codes et règlements de la liste.

Les dimensions sont indiquées en millimètres.

hu - HASZNÁLATI ÚTMUTATÓ

1 ALKATRÉSZRENDELÉS

Mindig adja meg a cikkszámot, a kért elemek nevét és mennyiségét, valamint a készülék típusát és gyári számát.

A Szerviz - "🔧" szimbólummal jelölt oldalak a szervizkészlet(ek) egyes alkatrészeire vonatkoznak. A készlet teljes tartalmát lásd az "1 - Service kits" (1 - Szervizkészletek) fejezetben.

2 A TÁBLÁZAT OSZLOPAI

Ref. - Hivatkozási szám: a felsorolt alkatrészt a megfelelő ábrához társítja. A rajzon csak hivatkozási számmal ellátott alkatrészek láthatók. Az ábra hivatkozási szám nélküli részei csak az összeszerelés módját illusztrálják.

Part number - ha nincs megadva cikkszám, az adott alkatrész nem kapható pótalkatrészként. A vastag vonal szerelvényt jelez. Ha a cikkszám után fekete pont áll, az alkatrész a jobbra fent vastaggal jelölt szerelvény része.

A „<<< >>>” jel átirányít egy másik listához, amely a „Name” elemmel azonos nevű.

Ha egy adott alkatrész cikkszámát a „Ref.”/„Name” oszlopba helyezik, ki kell választani a készülék típusát/verziószámát.

Qty - Mennyiség: az adott hivatkozási számhoz kapcsolódó alkatrészek számát jelöli. Az „AR” jelentése „As required” (igény szerint): itt megadhatja a mennyiséget vagy a számot.

Name - Az alkatrész neve: az angol nyelvű elnevezések fordításai az „Alkatrészek listája” c. dokumentumban található.

Remarks - Az alkatrésszel kapcsolatos többletinformáció.

Egy betűsor jelzi azt, hogy az adott alkatrészt az illetékes hatóság a lista kódjainak vagy szabályainak megfelelő tanúsítvánnyal látta el.

A mérési eredmények milliméterben értendők.

it - ISTRUZIONI PER L'USO

1 ORDINE DI PARTI DI RICAMBIO

Indicare sempre il numero categorico, il nome e la quantità delle parti richieste, come pure il tipo e il numero di serie della macchina.

Le pagine contrassegnate dal simbolo di assistenza - “” descrivono componenti appartenenti ai kit di manutenzione. Per informazioni sul contenuto completo del kit, consultare il capitolo “1 - Service kits” (1 - Kit di manutenzione).

2 INFORMAZIONI SULLE COLONNE

Ref. - Numero di riferimento: indica un componente specifico elencato nel disegno. Nel disegno sono presenti solo i componenti con un numero di riferimento. I componenti senza numero di riferimento sono presenti al solo scopo di illustrare il gruppo.

Part number - Numero categorico: se non è specificato nessun numero categorico, il componente non è disponibile come parte di ricambio. Una riga in grassetto indica un assemblaggio. Una parte il cui numero è seguito da un punto nero è compresa nell'assemblaggio stampato in grassetto in alto a destra.

“<<<<>>>>” indica di consultare un altro elenco di parti di ricambio.

Quando il numero di catalogo di una parte specifica è messo sotto la linea del riferimento/denominazione si deve fare una scelta in base al tipo/versione della macchina.

Qty - Quantità: indica il numero di componenti relativo al numero di riferimento. „AR“ significa „As required“ (Come richiesto): devono essere determinati la quantità o il numero.

Name - Nome parte: le traduzioni dei nomi inglesi dei componenti possono essere reperite nel “Glossary of part names” (Glossario dei nomi parti).

Remarks - Ulteriori informazioni sul componente.

Una serie di lettere possono indicare la certificazione di un componente da parte di un ente autorizzato specificato, in conformità alle normative riportate nell'elenco.

Le misure sono espresse in millimetri.

ja - 使用方法

1 部品の注文

部品番号、注文するアイテムの名称および数量、機器のタイプおよびシリアル番号を必ず指定してください。

サービスマーク “” のついたページにはサービスキットの部品が記載されています。キットの内容物については、第1章「サービスキット」を参照してください。

2 各列の説明

Ref. - 参照番号: リストの部品が図のどこにあるかを示します。参照番号がある部品のみが図に示されています。参照番号がない部品はアセンブリを表現するため便宜上表記されています。

Part number - 部品番号: 部品番号が示されていない部品は、スペア部品としては提供されていません。太字の行はアセンブリを示します。番号の後に黒い点が付いている部品は、すぐ上にある太字のアセンブリを構成しています。

“<<<<>>>>” は、“Name” と同じタイトルの別のリストを示します。

“Ref.” または “Name” 行の下に、特定の部品の部品番号が記載されている場合は、機器のタイプ/バージョンに応じて部品を選択してください。

Qty - 数量: 参照番号に対応する部品の数量を示します。 „AR” は「必要に応じて」を意味し、必要に応じて数量または番号を指定します。

Name - 部品名: 英語に対応する各言語の名称は「Glossary of part names」(部品名称対応表)に記載されています。

Remarks - 部品に関する追加情報です。

一連の文字列は特定の部品が指定認定団体によって承認されていることを示し、リストのコードまたは規定に準拠しています。

測定値はミリメートル単位で示されています。

lt - NAUDOJIMO INSTRUKCIJA

1 DETALIŲ UŽSAKYMAS

Visada nurodykite detalės numerį, pavadinimą ir reikiamą kiekį bei įrenginio tipą ir serijos numerį.

Puslapiuose, pažymetuose techninio aptarnavimo simboliu - “”, yra aptarnavimo reikmenų rinkinio (-ių) dalių. Norėdami gauti informacijos apie visą rinkinio turinį, žr. skyrių “1 - Service kits” (1 - Aptarnavimo reikmenų rinkiniai).

2 INFORMACIJA STULPELYJE

Ref. - Nuorodos numeris: susieja sąrašė nurodytą detalę ir brėžinį. Brėžinyje pavaizduotos tik detalės, turinčios nuorodos numerį. Brėžinio detalės, neturinčios nuorodos numerio, tik iliustruoja komplektinį bloką.

Part number - detalės numeris: jeigu detalės numeris nenurodytas, komponento kaip atsarginės detalės įsigyti negalima. Eilutėje, kuri parodyta paryškintu šriftu, yra agregatas.

Detalė, po kurios numerio eina juodas taškas, yra įmontuota paryškintu šriftu aukščiau išspausdintame agregate.

„<<<<>>>>“ nukreipia į kitą sąrašą, kurio pavadinimas toks pat, kaip „Name“ (detalės pavadinimas).

Kai specifinės detalės numeris yra nurodytas žemiau „Ref.“ (nuoroda) / „Name“ (detalės pavadinimas) eilutės, reikia apsispręsti dėl įrenginio tipo/versijos.

Qty - Kiekis: naudojamas su atitinkamu nuorodos numeriu ir nurodo detalių kiekį. “AR” reiškia „As required“ (prireikus): dar nežinomas kiekis ar skaičius.

Name - detalės pavadinimas: angliškų pavadinimų vertimus galima rasti dokumente “Įrangos dalių terminai”.

Remarks - Papildoma informacija apie detalę.

Raidžių derinys gali rodyti, kad konkrečiai detalei sertifikuotą išdavė įgaliota institucija pagal sąrašo nurodymus ir taisykles.

Matmenys pateikti milimetrais.

lv - INSTRUKCIJAS LIETOŠANAI

1. PASŪTĪŠANAS DETALĀS

Vienmēr norādiet nepieciešamās iekārtas detaļas numuru, nosaukumu un daudzumu, kā arī tipu un mašīnas seriālo numuru.

Lappuses, kas apzīmētas ar apkopes simbolu - "🔧" satur Apkopes komplekta(u) daļas. Pilnam komplekta satura pārskatam, skatiet nodaļu "1 - Service kits" (1 - Apkopes komplekti).

2. KOLONNAS INFORMĀCIJA

Ats. - Inventāra numurs: savieno atbilstošās saraksta daļas ar attēlu. Tikai detaļas ar inventāra numuru ir parādītas attēlā. Detaļas attēlā bez inventāra numura ir montāžai, vienkārši paskaidrotas attēlā.

Part number – detaļas numurs: ja nav norādīts detaļas numurs, komponents nav pieejams kā rezerves detaļa. Treknrakstā parādītā līnija ir montāža. Detaļa, aiz kuras numura seko melns punkts, ir ietverta tieši augšpusē treknrakstā drukātajā montāžā.

"<<< >>>" novirza uz citu sarakstu, kuram ir tāds pats nosaukums kā "Nosaukums".

Kad kādas noteiktas detaļas numurs ir novietots zem līnijas "Ats."/"Nosaukums" ir jāizvēlas iekārtas veids/versija.

Qty – daudzums: norāda detaļas daudzumu savienojumā ar attiecīgo inventāra numuru. "AR" nozīmē "As required" (pēc vajadzības): daudzums vai numurs, kuru jānosaka.

Name – detaļas nosaukums: angļu nosaukumu tulkojumus var atrast dokumentā "Detaļu nosaukumu vārdnīca".

Remarks – speciāla informācija par detaļu.

Burtu rindīņa, saskaņā ar saraksta noteikumiem un kodiem, var norādīt, ka šo detaļu ir sertificējusi autorizēta organizācija.

Izmēri ir norādīti milimetros.

nl - INSTRUCTIES VOOR HET GEBRUIK

1 BESTELLEN VAN ONDERDELEN

Vermeld altijd het onderdeelnummer, de benaming en de hoeveelheid van de gewenste onderdelen, alsmede het type en het serienummer van de machine.

Pagina's gemarkeerd met het servicesymbool - "🔧" bevatten onderdelen uit servicekits. Voor de complete inhoud van de kit, zie paragraaf "1 - Service kits" (1 - Servicekits).

2 KOLOM INFORMATIE

Ref. - Referentienummer: koppelt een specifiek onderdeel in de lijst aan de desbetreffende tekening. Alleen onderdelen met een referentienummer zijn in de tekening afgebeeld.

Onderdelen zonder referentienummer die op de tekening voorkomen, worden slechts getoond om het samenstel te illustreren.

Part number - Onderdeelnummer: indien geen onderdeelnummer is aangegeven, is de betreffende component niet als reserveonderdeel verkrijgbaar. Een regel in een vet lettertype is een samenstel. Een onderdeel waarvan het nummer gevolgd wordt door een zwart rondje, maakt deel uit van het vet afgedrukte samenstel direct erboven.

"<<< >>>" verwijst naar een andere lijst met dezelfde titel als de "Name" (benaming).

Als het onderdeelnummer van het desbetreffende onderdeel onder de regel "Ref."/"Name" (Ref./Benaming) staat vermeld, moet er een keuze met betrekking tot het machinetype en de machineversie worden gemaakt.

Qty - Aantal: geeft het aantal onderdelen aan in samenhang met het overeenkomstige referentienummer. "AR" betekent "As required" (benodigde hoeveelheid): de hoeveelheid of het aantal moet nader worden bepaald.

Name - Naam van het onderdeel: vertalingen van de Engelse benamingen zijn te vinden in het document "Glossary of part names" (Woordenlijst van onderdelen).

Remarks - Extra informatie over het onderdeel.

Een reeks letters kan aangeven dat een bepaald onderdeel gecertificeerd is door het opgegeven bevoegde orgaan, in overeenstemming met de codes of voorschriften in de lijst.

Afmetingen zijn in millimeters vermeld.

no - BRUKSANVISNING

1 BESTILLING AV DELER

Angi alltid delenummeret, navnet og antallet deler samt type- og serienummeret for maskinen.

Sidene som er merket med Service-symbolet - "🔧", omtaler deler av servicesettene. Du finner informasjon om hele innholdet i settet i kapittel "1 - Service kits" (1 - Servicesett).

2 FORKLARING TIL KOLONNENE

Ref. – Referansenummer: knytter en bestemt del i listen til tegningen. Deler uten referansenummer vises ikke på tegningen. Delene på tegningen som ikke har referansenummer, er tatt med for å illustrere monteringen.

Part number – Delenummer: Hvis det ikke er angitt noe delenummer, kan ikke delen bestilles som reservedel. En fet linje er en montering. En del som har et nummer som er et-terfulgt av en svart prikk, er omfattet i monteringen med fet skrift ovenfor.

"<<< >>>" henviser til en annen liste som heter det samme som "Navn".

Når delenummeret til en bestemt del plasseres under linjen "Ref."/"Name" må man velge hva slags type/versjon maskinen er.

Qty – Antall: angir hvor mange deler som er knyttet til referansenummeret. "AR" står for "As required" ("etter behov"): Antall eller nummer må spesifiseres.

Name – Delenavn: Oversettelsene av de engelske navnene finner du i dokumentet Ordliste med delnavn.

Remarks – Anmerkninger: tilleggsinformasjon om delene.

Bokstaver kan indikere at en bestemt del er sertifisert i henhold til det autoriserte organet som er angitt, i samsvar med kodene eller reglene for listen.

Mål er angitt i millimeter.

pl - INSTRUKCJA UŻYTKOWANIA

1 ZAMAWIANIE CZĘŚCI

Zawsze podawać numer części, nazwę i ilość potrzebnych elementów, a także typ i numer seryjny urządzenia.

Strony oznaczone symbolem - "🔧" zawierają części zestawów serwisowych. Pełną zawartość zestawów można znaleźć w rozdziale "1 - Service kits" (1 - Zestawy serwisowe).

2 OBJAŚNIENIA KOLUMN

Ref. - Numer referencyjny: łączy konkretną część z listy ze schematem. Na schemacie prezentowane są wyłącznie części posiadające numer referencyjny. Części na schemacie nie mające numeru referencyjnego umieszczono w celu zilustrowania montażu.

Part number - Numer części: jeśli nie podano numeru części, dany element nie jest dostępny jako część zapasowa. Tekst wytłuszczony oznacza zespół. Część, po numerze której występuje czarna kropka, wchodzi w skład wytłuszczonego zespołu wskazanego powyżej po prawej stronie.

„<<< >>>” służą do przechodzenia do innej listy o tym samym tytule, co w kolumnie „Name” (Nazwa).

Jeśli numer dla konkretnej części jest umieszczony poniżej wiersza „Ref.”/„Name”, należy wybrać typ/wersję maszyny.

Qty - Ilość: oznacza liczbę części w odniesieniu do odpowiadającego im numeru referencyjnego. „AR” oznacza „As required” (Wg zapotrzebowania): ilość zostanie uzgodniona.

Name - Nazwa części: tłumaczenie nazw angielskich można znaleźć w dokumencie „Glossary of part names” (Słownik części).

Remarks - Informacje dodatkowe o danej części.

Ciąg liter może informować, że dana część uzyskała certyfikat określonej, upoważnionej organizacji, zgodnie z kodami lub zasadami z listy.

Wymiary zostały podane w milimetrach.

pt - INSTRUÇÕES PARA UTILIZAÇÃO

1 ENCOMENDA DE PEÇAS

Especificar sempre a referência da peça, o nome e a quantidade de itens necessários, bem como o tipo e o número de série da máquina.

Páginas marcadas com o símbolo de assistência -  contêm peças de kits de assistência. Para ver todos os conteúdos do kit consultar o capítulo "1 - Service kits" (1 - Kits de assistência).

2 INFORMAÇÃO SOBRE AS COLUNAS

Ref. - Número de referência: estabelece a ligação entre uma peça específica listada e o desenho. No desenho, apenas são mostradas peças com um número de referência. As peças mostradas no desenho que não apresentem um número de referência servem apenas para ilustrar o conjunto.

Part number - Referência da peça: se não for indicada a referência da peça, o componente não está disponível como peça sobresselente. Uma linha em negrito representa um conjunto. Uma peça cujo número esteja seguido de um ponto preto está incluída no conjunto impresso em negrito, imediatamente acima.

"<<< >>>" conduz a outra lista com o mesmo título de "Name".

Quando a referência da peça específica se encontra por baixo da linha "Ref./"Name", é preciso escolher o tipo/versão da máquina.

Qty - Quantidade: indica o número de peças relacionadas com o número de referência correspondente. "AR" significa "As required" (consoante requerido): quantidade ou número a determinar.

Name - Nome da peça: é possível encontrar traduções dos nomes ingleses das peças no documento "Glossário de designações de peças".

Remarks - Informação extra sobre a peça.

Uma série de letras pode indicar que uma determinada peça foi certificada pela entidade autorizada referida, de acordo com os códigos ou as normas da lista.

As medidas são indicadas em milímetros.

ro - INSTRUCȚIUNI DE UTILIZARE

1 COMANDAREA PIESELOR

Specificați întotdeauna numărul de reper, numele și cantitatea articolelor necesare și tipul și numărul de serie ale mașinii.

Paginile marcate cu simbolul Service -  conțin componente din kituri de service. Pentru conținutul complet al acestui kit consultați capitolul "1 - Service kits" (1 - Kituri de service).

2 INFORMAȚIILE DIN COLOANE

Ref. - Numărul de referință: corelează piesa respectivă din listă cu desenul. În desen sunt prezentate numai piesele care au numere de referință. Piesele din desen care nu au niciun număr de referință se află acolo numai pentru a ilustra ansamblul.

Part number - Număr de reper: dacă nu este specificat niciun număr de reper, componenta nu este disponibilă ca piesă de schimb. O linie îngroșată reprezintă un ansamblu. Un reper al cărui număr este urmat de un punct negru este cuprins în ansamblul tipărit îngroșat de deasupra sa.

"<<< >>>" direcționează către o altă listă care are titlul identic cu "Nume".

Când numărul de reper al piesei respective este plasat sub linia "Referință"/"Nume", este obligatorie selectarea unui tip sau a unei versiuni a mașinii.

Qty - cantitate: indică numărul de piese corespunzătoare numărului de referință respectiv. "AR" înseamnă "Conform necesar": cantitate sau număr care urmează a fi determinat.

Name - Nume reper: traducerea numelor englezești pot fi găsite în documentul "Glosar de nume de repere".

Remarks - Informații suplimentare despre piese.

O serie de litere poate indica faptul că o anumită piesă a fost certificată de organismul de autorizare specificat, în conformitate cu regulile sau codurile listei.

Dimensiunile sunt date în milimetri.

ru - Правила пользования

1 ЗАКАЗ ДЕТАЛЕЙ

Всегда указывайте номер по каталогу, наименование и количество требуемых позиций, а также тип и серийный номер машины. Страницы, помеченные символом Service - , содержат информацию о сервисном(ых) наборе(ах). Полное содержание сервисного набора приведено в главе "1 - Service kits" (1 - Сервисные наборы).

2 ИНФОРМАЦИЯ О СТОЛБЦЕ

Ref. - Справочный номер: связывает деталь, указанную в списке, с чертежом. На чертеже показаны только детали, имеющие справочные номера. Детали на чертеже без справочных номеров показаны только для иллюстрации сборки.

Partnumber - Каталогный номер: если каталожный номер не указан, то данный компонент нельзя заказать как запчасть. Жирным шрифтом показаны сборочные единицы. Деталь, после номера которой следует черная точка, входит в состав сборочной единицы, набранной жирным шрифтом непосредственно над ней. Кавычки "<<< >>>" ссылаются на другой список того же наименования, что и "Name" (Наименование детали).

Если каталожный номер находится под линией "Ref./"Name", это означает, что необходимо сделать выбор в соответствии с типом/исполнением машины.

Qty - Количество: указывает количество деталей в соответствии с их справочным номером. "AR" означает "As required" (По требованию): количество или номер необходимо определить.

Name - Наименование детали: перевод английских наименований находится в "Glossary of Part Names" (Словаре наименований деталей).

Remarks - Примечания - дополнительная информация о детали. Ряд букв может означать, что конкретная деталь сертифицирована указанным уполномоченным лицом, в соответствии с кодами или правилами в перечне. Размеры даны в миллиметрах.

sk - NÁVOD NA POUŽITIE

1 OBJEDNÁVANIE SÚČASTÍ

Vždy zadajte číslo súčasti, názov a množstvo požadovaných položiek a takisto typ a výrobné číslo zariadenia.

Strany označené servisným symbolom -  obsahujú časti servisnej súpravy/servisných súprav. Úplný zoznam príslušnej súpravy nájdete v kapitole "1 - Service kits" (1 - Servisné súpravy).

2 INFORMÁCIE V STĹPCOCH

Ref. - Referenčné číslo: slúži na prepojenie konkrétnej uvedenej súčasti k príslušnému výkresu. Na výkrese sú zobrazené len súčasti s referenčným číslom. Súčasti bez referenčného čísla na výkrese slúžia len na ilustráciu montážnej skupiny.

Part number - Číslo súčasti: ak nie je určené žiadne číslo súčasti, daný komponent nie je k dispozícii ako náhradná súčiastka. Riadok uvedený tučným písmom predstavuje montážnu skupinu. Súčasť, za ktorej číslom nasleduje čierna bodka, je zahnutá vo vyššie uvedenej hrube vytlačenej zostave vpravo.

„<<< >>>“ smeruje na ďalší zoznam s rovnakým názvom ako v položke „Name“.

Keď sa číslo určitej súčasti nachádza pod riadkom „Ref./"Name“, je potrebné vybrať typ/verziu zariadenia.

Qty - Množstvo: označuje počet súčastí vzhľadom na príslušné referenčné číslo. Skratka „AR“ znamená „As required“ (podľa potreby): množstvo alebo číslo bude stanovené.

Name - Názov súčastky: preklady anglických názvov môžete nájsť v dokumente „Register názvov súčastí“.

Remarks - Ďalšie informácie o danej súčasti.

Postupnosť písmen môže určovať, že určitá súčasť bola certifikovaná stanovenou oprávnenou inštitúciou podľa kódov alebo pravidiel v danom zozname.

Rozmery sú uvedené v milimetroch.

sl - NAVODILA ZA UPORABO

1 NAROČANJE DELOV

Vedno navedite številko dela, ime in količino zahtevanih predmetov ter tip in serijsko številko stroja.

Strani, označene s simbolom za servis "🔧", vsebujejo dele servisnih kompletov. Za celotno vsebino kompleta si oglejte poglavje "1 - Service kits" (1 - Servisni kompleti).

2 INFORMACIJE O STOLPCU

Ref. - Referenčna številka: povezuje določen navedeni del z risbo. Na risbi so prikazani samo deli z referenčno številko. Deli na risbi, ki nimajo referenčne številke, so namenjeni samo prikazu sklopa.

Part number - Številka dela: če številka dela ni navedena, komponenta ni na voljo kot rezervni del. Vrstica z odebeljenim tiskom predstavlja sklop. Del, katerega številki sledi črna pika, spada v sklop, natisnjen z odebeljenim tiskom neposredno nad njim.

"<<< >>>" vas usmeri na drug seznam z enakim nazivom kot "Name (Ime)".

Če je pod vrstico "Ref."/"Name" navedena številka dela za določeni del, mora izbrati temeljiti na tipu/različici stroja.

Qty - Količina: določa število delov v povezavi z ustrežno referenčno številko. "AR" pomeni "As required" (kot je zahtevano): količina ali število za določitev.

Name - Ime dela: prevodi angleških imen se nahajajo v dokumentu "Pojmovnik z imeni delov".

Remarks - Dodatne informacije o delu.

Zaporedje črk lahko pomeni, da je bil določen del certificiran s strani navedenega pooblaščenega organa, v skladu z zakoni ali pravili seznama.

Mere so podane v milimetrih.

sv - INSTRUKTIONER FÖR ANVÄNDNING

1 BESTÄLLA DELAR

Ange alltid reservdelsnummer, namn och antal delar som önskas, samt typbeteckning och tillverkningsnummer på maskinen.

Sidor markerade med servicesymbolen - "🔧" innehåller delar av servicesatser. Hela innehållet i satsen redovisas i kapitlet "1 - Service kits" (1 - Servicesatser).

2 SPALTINFORMATION

Ref. - Referensnummer: kopplar ihop en viss reservdel i förteckningen med ritningen. Endast reservdelar med referensnummer visas i ritningen. Reservdelar som saknar referensnummer i ritningen finns med för att illustrera själva monteringen.

Part number - Reservdelsnummer: om reservdelsnummer saknas finns komponenten inte som reservdel. Monteringsanvisningar visas med fet stil. En reservdel vars nummer följs av en svart punkt finns med i den fetstilta monteringsanvisningen direkt ovanför.

"<<< >>>" hänvisar till en annan lista med samma titel som "namnet".

När reservdelsnumret för den specifika delen är placerad nedanför "Ref."/"Namn"-raden måste ett val göras utifrån maskinens typ/version.

Qty - Antal: anger hur många delar som är kopplade till motsvarande referensnummer. "AR" betyder "As required" (som erfordras): antal eller nummer bestäms senare.

Name - Reservdelsbeteckningar: översättningar av de engelska beteckningarna återfinns i dokumentet "Glossary of part names" (Ordlista med reservdelsbeteckningar).

Remarks - Extrainformation om reservdelen.

En uppsättning bokstäver kan ange att en viss reservdel har certifierats av det befulldäktiga organet, enligt koderna eller reglerna i förteckningen.

Mått anges i millimeter.

tr - KULLANIM TALİMATLARI

1 PARÇA SİPARİŞİ

Gerekli öğelerin parça numaraları, ad ve miktarının yanı sıra makinenin tip ve seri numarasını da mutlaka belirtin.

Servis simgesi - "🔧" taşıyan sayfalarda Servis kiti (kitleri) parçaları bulunmaktadır. Kitle ilgili tüm bilgilere ulaşmak için "1 - Service kits" (1 - Servis kitleri) bölümüne başvurun.

2 KOLON BİLGİLERİ

Ref. - Referans numarası: özel olarak listelenmiş bir parça için çizimden bağlantı sağlar. Sadece referans numarası olan parçalar çizimde gösterilir. Çizimde referans numarası bulunmayan parçalar sadece montaj işlemlerini göstermek için verilmiştir.

Part number - Parça numarası: parça numarası belirtilmemişse, bileşen yedek parça olarak bulunmamaktadır. Koyu harflerle gösterilen satır montajdır. Numarasından sonra siyah bir nokta gelen parça, yukarıda koyu harflerle basılmış montaja dahildir.

"<<< >>>", "Name" (Ad) ile aynı başlıkta bir başka listeye yönlendirir.

Belirli bir parçanın parça numarası "Ref."/"Name" (Ref./Ad) satırının altına yerleştirildiğinde, makine tipi/modeli konusunda seçim yapılmalıdır.

Qty - Miktar: uygun referans numarasıyla bağlantılı olarak parça sayısını gösterir. "AR", "As required" (Gerektiği gibi) anlamına gelmektedir: belirlenecek olan miktar veya sayı.

Name - Parça adı: İngilizce adların çevirileri, "Parça adları sözlüğü"nde bulunabilir.

Remarks - Açıklamalar: Parça hakkında ek bilgiler.

Bir dizi harf, belirli bir parçanın yasalara veya liste kurallarına uygun olarak özel yetkili bir makam tarafından sertifikalandırıldığını gösterebilir.

Ölçümler milimetre cinsinden verilmiştir.

zh - 使用说明

1 订购零件

订购零件时必需指定零件号、零件名称、零件数量以及机器的类型和系列号。

在标有维修标记 "🔧" 的页面上有维修组件的部分内容。该组件的完整内容请参见章节 "1 - 维修组件" "1 - Service kits"。

2 每列内容的说明

Ref. - 图示编号：将零件清单中列出的零件与示意图中的该零件相关联。零件清单中仅显示有图示编号的零件。示意图中没有标注图示编号的零件仅用来在图中帮助示意。

Part number - 零件号：如果某项没有零件号，则该项不可作为零备件供应。以粗体印刷的零件号表示这是一个装置。编号后面有一个黑点的零件包含在其上面以粗体印刷的装置中。

"<<< >>>" 表示该装置的零件清单在手册中以同一名称另外分章单列。

如果指定的零件号位于 "Ref." (图示编号) "Name" (零件名称) 列上，则订购零件时必须指明机器的类型/版本。

Qty - 数量：显示相应的图示编号的零件个数。"AR" 表示 "As required"：即根据需要确定数量。

Name - 零件名称：在文件 "零件名称对照表" 中可以找到对应的英文名称。

Remarks - 零件的附注。

一连串的字母表示某一特定零件依照标准或规定的要求已获得指定授权机构的认证。

Table of contents

1	Service kits	15
2	Drive arrangement.....	19
3	Air system - Air inlet	21
4	Air system - Air outlet and drains - Pack	23
5	Air system - Air outlet and drains - Full Feature - GA 15 VSD.....	27
6	Air system - Air outlet and drains - Full Feature - GA 18 VSD, GA 22 VSD, GA 26 VSD, GA 30 VSD	29
7	Air system - Air dryer - Full Feature - GA 15 VSD	31
8	Air system - Air dryer - Full Feature - GA 18 VSD, GA 22 VSD, GA 26 VSD, GA 30 VSD.....	35
9	Oil system - Oil separator module	43
10	Oil system - Air receiver/Oil vessel.....	45
11	Oil system - Cooler connections.....	47
12	Cubicle - IEC/UL-cUL	49
13	Bodywork.....	67
14	Standard option - Heavy duty filter	73
15	Standard option - DD filter - GA 15 VSD	75
16	Standard option - DD filter - GA 18 VSD, GA 22 VSD, GA 26 VSD, GA 30 VSD.....	77
17	Standard option - DD/PD filter - GA 15 VSD	79
18	Standard option - DD/PD filter - GA 18 VSD, GA 22 VSD, GA 26 VSD, GA 30 VSD.....	81
19	Standard option - DD/PD filter - Parts	83
20	Standard option - Air dryer bypass - GA 15 VSD	87
21	Standard option - Air dryer bypass - GA 18 VSD, GA 22 VSD, GA 26 VSD, GA 30 VSD.....	89
22	Standard option - Lifting device.....	91
23	Standard option - Rain protection.....	93

24	Standard option - Oil separator condensate drain	95
25	Standard option - Oil separator condensate drain - Parts	97
26	Standard option - Energy recovery system	99
27	Standard option - Pre-filter	101
28	Standard option - Main switch	103

1

No drawing

Service kits

1

Ref.	Part number	Qty	Name	Remarks
		1	Oil	
	2901 0245 01		Roto-Inject Fluid - 5 litres	
	2901 0522 00		Roto-Inject Fluid - 20 litres	
	2901 1700 00		Roto-Xtend Duty Fluid - 5 litres	
	2901 1701 00		Roto-Xtend Duty Fluid - 20 litres	
	2901 1954 00	1	Motor overhaul kit	
	0335 2160 00	• 1	Circlip	
	0502 1100 04	• 1	Ball bearing	
	0508 1100 78	• 1	Roller bearing	
	1622 0919 00	• 1	Lipseal	
	1622 3740 00	• 1	Drain nipple	
	1622 6991 00	• 1	Bushing	
	0335 1142 00	• 1	External circlip	
	0666 8000 18	• 1	Seal	
	1089 0679 12	• 1	Fan	
	0335 1140 00	• 1	Circlip	
	0686 3718 16	• 1	Plug	
	2904 0189 00	• 1	Instruction	
	9820 9717 00	• 1	Instruction	
	2901 1956 00	1	Lipseal kit	
	0686 3718 16	• 1	Drain plug	
	1622 0919 00	• 1	Lipseal	
	1622 3740 00	• 1	Drain nipple	
	1622 6991 00	• 1	Bushing	
	2901 1958 00	1	Element mounting kit	
	0663 2103 22	• 1	O-ring	
	0663 3119 00	• 1	O-ring	
	0663 3130 00	• 1	O-ring	
	1622 7924 00	• 1	Gasket	
	1622 7886 00	• 2	Gasket	
	2901 1960 00	1	Oil stop/Check valve kit	
	0211 1337 00	• 4	Bolt	
	0663 3119 00	• 1	O-ring	
	0663 3130 00	• 1	O-ring	
	0663 7134 00	• 1	O-ring	
	0686 3718 24	• 1	Plug	
	1613 2359 00	• 1	Piston	
	1622 9089 00	• 1	Valve body	
	1622 0796 00	• 1	Spring	
	1622 5662 00	• 1	Spring	
	1622 7924 00	• 1	Gasket	
	1622 5934 00	• 1	Valve	
		1	Air/Oil filter kit	
	2901 1961 00		4000hrs	
	0663 2102 15	• 1	O-ring	
	1089 9556 22	• 1	Filter	
	1089 9556 23	• 1	Filter	
	1613 8720 00	• 1	Filter element	
	1622 7836 00	• 1	Oil filter	

1

Service kits

Ref.	Part number	Qty	Name	Remarks
	2901 1962 00	1	Air/Oil filter kit	
	0663 2102 15 •	1	O-ring	
	1089 9556 22 •	2	Filter	
	1089 9556 23 •	2	Filter	
	1613 8720 00 •	2	Filter element	
	1622 7837 00 •	1	Oil filter	
	2901 1077 00	1	Scavenge line kit	
	0661 1000 38 •	1	Seal washer	
	0663 2108 11 •	1	O-ring	
	1613 9005 01 •	1	Non return valve	
	0663 3119 00 •	2	O-ring	
	2901 1963 00	1	Oil separator kit	
	0663 2106 97 •	2	O-ring	
	1625 7036 00 •	1	Oil separator	
	2903 7836 00	1	Oil filter kit	
	1622 7836 00 •	1	4000hrs Oil filter	
	2903 7837 00	1	Oil filter kit	
	1622 7837 00 •	1	8000hrs Oil filter	
	2901 0997 00	1	Minimum Pressure Valve kit	
	0661 1000 61 •	1	Seal	
	0663 2101 30 •	1	O-ring	
	0663 7137 00 •	1	O-ring	
	1622 0522 01 •	1	Piston	
	1622 9078 80 •	1	Valve disk	
	1622 0525 00 •	1	Spring	
	2901 1616 00	1	Thermostat 40°C kit	
	0663 2101 95 •	1	O-ring	
	1622 7064 01 •	1	Thermostat 40°C	
	2901 1617 00	1	Thermostat 60°C kit	
	0663 2101 95 •	1	O-ring	
	1622 7064 04 •	1	Thermostat 60°C	
	2901 1618 00	1	Thermostat 75°C kit	
	0663 2101 95 •	1	O-ring	
	1622 7064 05 •	1	Thermostat 75°C	
	2901 1973 00	1	Preventive maintenance kit	
	2901 0997 00 •	1	8000hrs - 4000hrs oil filter	
	2901 1077 00 •	1	Minimum Pressure Valve kit	
	2901 1960 00 •	1	Scavenge line kit	
	2901 1961 00 •	1	Oil stop/Check valve kit	
	2901 1961 00 •	1	Air/Oil filter 4000hrs kit	
	2901 1963 00 •	1	Oil separator kit	

Service kits**1**

Ref.	Part number	Qty	Name	Remarks
	2901 1971 00	1	Preventive maintenance kit	
	2901 0997 00 •	1	8000hrs - 8000hrs oil filter	
	2901 1077 00 •	1	Minimum Pressure Valve kit	
	2901 1960 00 •	1	Scavenge line kit	
	2901 1962 00 •	1	Oil stop/Check valve kit	
	2901 1963 00 •	1	Air/Oil filter 8000hrs kit	
			Oil separator kit	

2

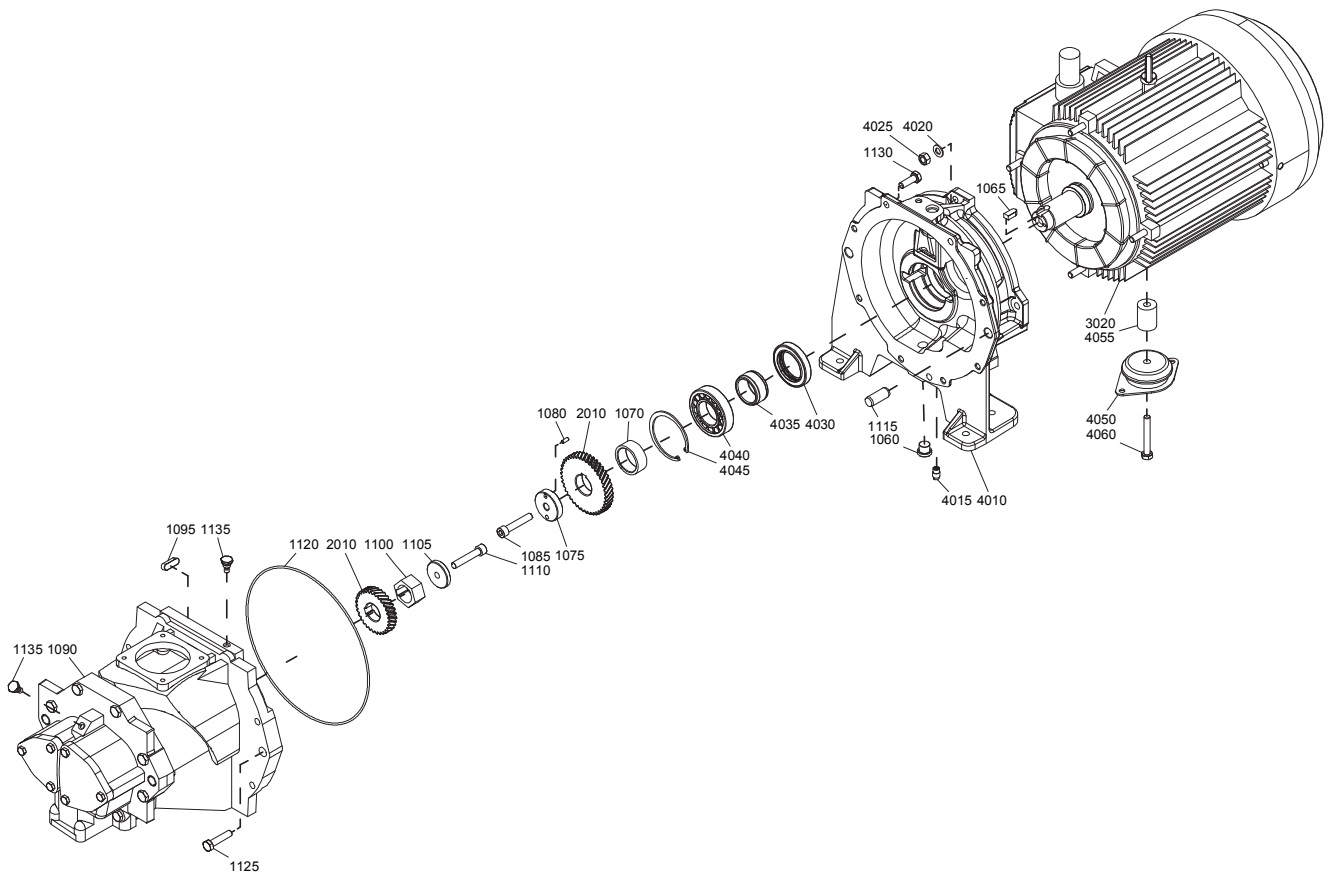

Drive arrangement

2

Ref.	Part number	Qty	Name	Remarks
1060	0686 3718 16	1	Plug	
1065	0337 0009 83	1	Parallel key	
1070	1622 6994 01	1	Spacer	
1075	1622 6995 00	1	Washer	
1080	0101 2274 00	2	Pin	
1085	0211 1368 00	1	Screw	
1090	1616 7382 80	1	Element	
1095	0337 0009 45	1	Key	
1100	1622 3400 00	1	Spacer	
1105	1622 3401 00	1	Washer	
1110	0211 1368 00	1	Screw	
1115	0101 1951 40	2	Pin	
1120	0663 2103 22	1	O-ring	
1125	0147 1366 03	6	Hexagon bolt	
1130	0147 1363 03	2	Hexagon bolt	
1135	1619 6032 00	2	Nipple (SPM)	
2010		1	Gear set	
	1622 6988 79		GA 15 VSD	
	1622 6988 76		GA 18 VSD	
	1622 6988 80		GA 22 VSD	
	1622 6988 81		GA 26 VSD	
	1622 6988 73		GA 30 VSD	
		1	Motor assembly	
	1622 7806 01		GA 15 VSD	
	1622 7807 01		GA 18 VSD	
	1622 7808 01		GA 22 VSD	
	1622 7809 01		GA 26 VSD	
	1622 7810 01		GA 30 VSD	
3020		• 1	Motor	
4010	1622 5945 00	• 1	Gearbox	
4015	1622 3740 00	• 1	Drain nipple	
4020	0301 2344 00	• 4	Washer	
4025	0266 2111 00	• 4	Nut	
4030	1622 0919 00	• 1	Lipseal	
4035	1622 6991 00	• 1	Bushing	
4040	0508 1100 78	• 1	Bearing roller	
4045	0335 2160 00	• 1	Circlip	
4050	1613 6752 16	• 1	Antivibration pad	
4055	1622 6936 00	• 1	Spacer	
4060	0147 1371 03	• 1	Hexagon bolt	

3

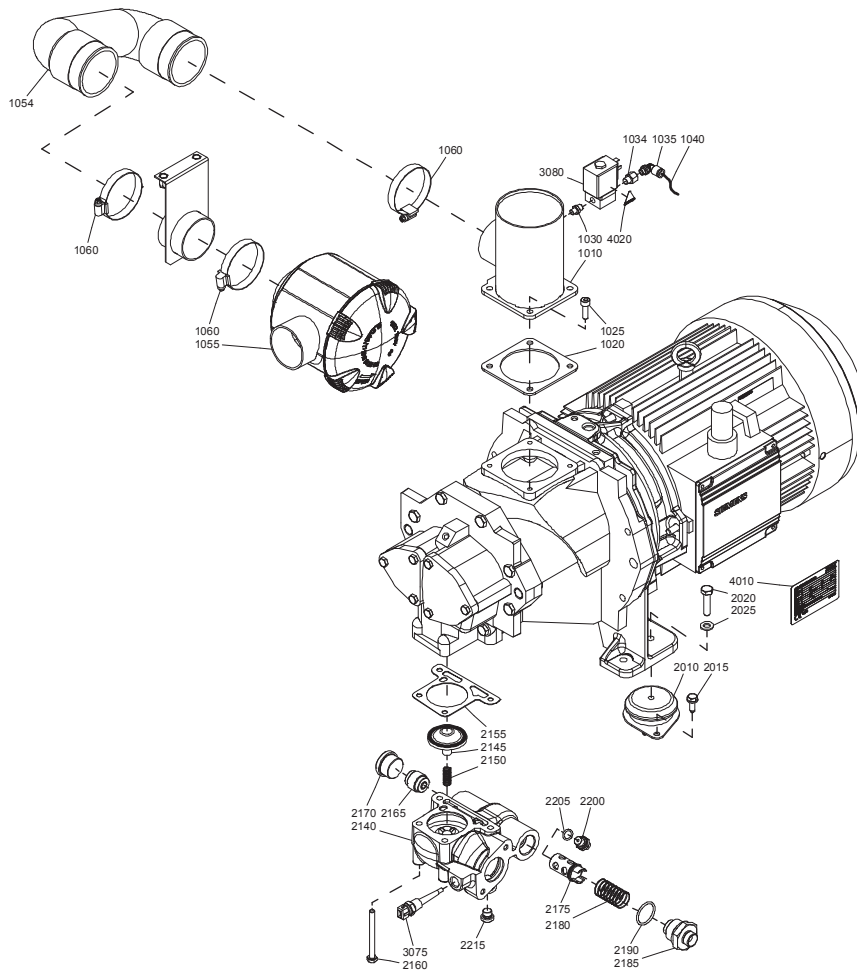

Air system - Air inlet

3

Ref.	Part number	Qty	Name	Remarks
1010	1625 7032 20	1	Arrester	
1020	1625 7954 00	1	Gasket	
1025	0211 1325 03	4	Screw	
1030	1622 7873 00	1	Nipple	
1034	1613 6968 03	1	Nozzle	
1035	0583 8120 75	1	Coupling	
1040	0070 6002 05	AR	Plastic tube	
1054	1625 7004 81	1	Hose assembly	
1055	1622 7887 00	1	Air filter	
	1613 8720 00 •	1	Filter element	
1060	0347 6114 00	3	Hose clip	
2010	1613 6752 01	2	Antivibration pad	
2015	0147 1963 08	6	Hexagon bolt	
2020	0147 1365 03	2	Hexagon bolt	
2025	0301 2344 00	2	Washer	
2140	1622 5922 00	1	Valve housing	
2145	1622 5934 00	1	Valve	
2150	1622 0796 00	1	Spring	
2155	1622 7924 00	1	Gasket	
2160	0211 1337 00	4	Bolt	
2165	1613 2359 00	1	Piston	
2170	0686 3718 19	1	Plug	
2175	1622 9089 00	1	Valve body	
2180	1622 5662 00	1	Spring	
2185	1622 7844 00	1	Nipple	
2190	0663 3130 00	1	O-ring	
2200	0571 0035 93	1	Nipple	
2205	0663 3119 00	1	O-ring	
2215	0686 3718 24	1	Plug	
3075	1089 0574 70	1	Temp. sensor	
3080	1089 0722 03	1	Solenoid valve	
4010	1625 8499 00	2	Data label	
4020	1088 1001 01	1	Warning mark	

4

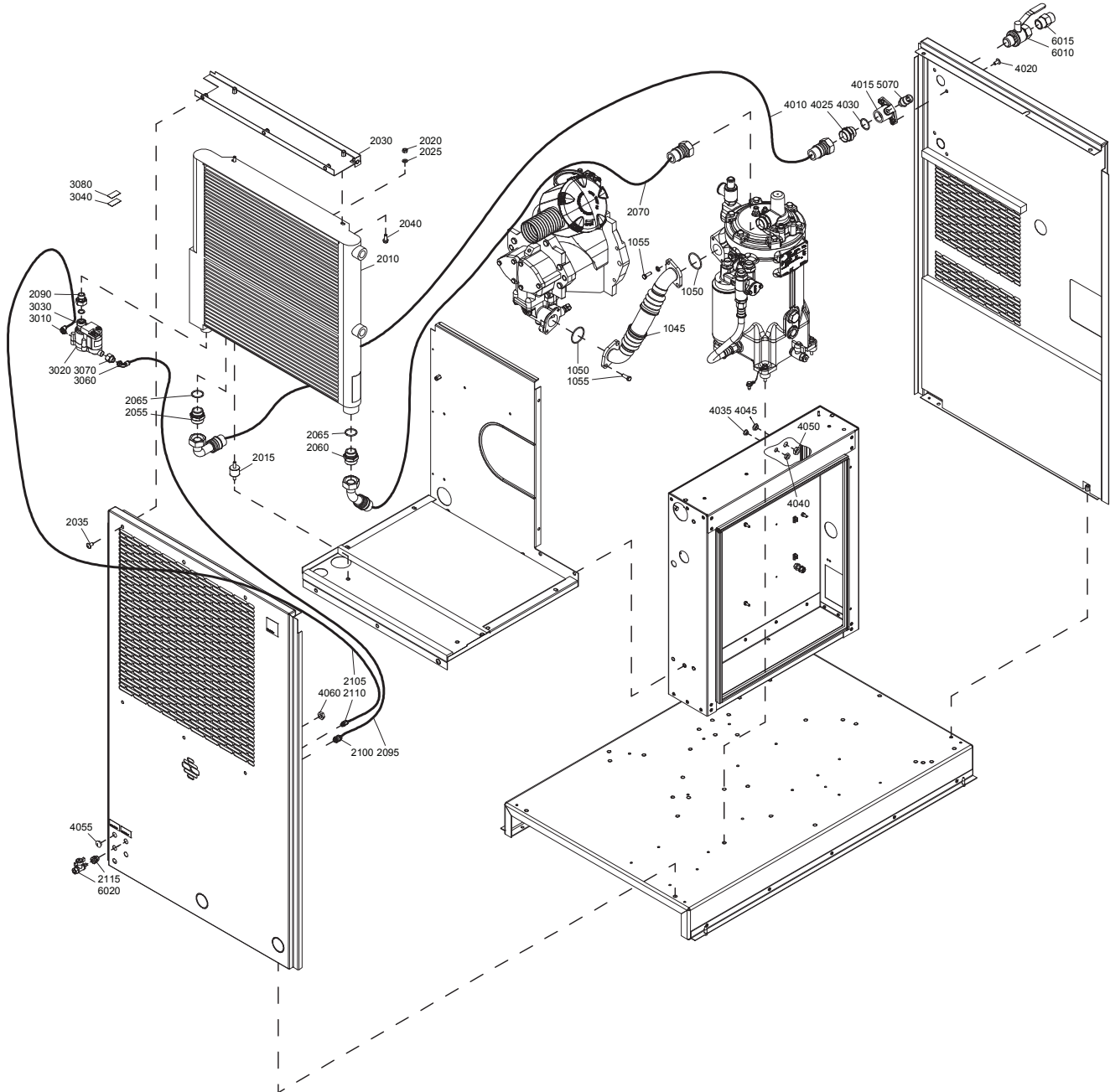

Air system - Air outlet and drains - Pack

4

Ref.	Part number	Qty	Name	Remarks
1045	1622 6990 00	1	Hose assembly	
1050	0663 7134 00	2	O-ring	
1055	0147 1325 03	4	Hexagon bolt	
2010		1	Cooler	
	1622 7830 02		GA 15 VSD	
	1622 7830 03		GA 18 VSD	
	1622 7830 04		GA 22 VSD	
	1622 7830 05		GA 26 VSD	
	1622 7830 05		GA 30 VSD	
2015	0392 1100 29	2	Vibration damper	
2020	0266 2110 00	2	Nut	
2025	0301 2335 00	2	Washer	
2030		1	Support	
	1622 7868 00		GA 15 VSD	
	1622 7848 00		GA 18 VSD	
	1622 7822 00		GA 22 VSD	
	1622 6959 00		GA 26 VSD	
	1622 6959 00		GA 30 VSD	
2035	0215 0006 14	3	Screw	
2040	0147 1963 08	2	Hexagon bolt	
2055	0571 0036 31	1	Nipple	
2060	0571 0036 01	1	Nipple	
2065	0663 3130 00	2	O-ring	
2070	0574 9918 24	1	Hose assembly	
2090	2202 7618 00	1	Pipe union	
2095	0070 6002 05	AR	Plastic tube	
2100	0583 8100 70	1	Coupling	
2105	0070 6002 04	AR	Plastic tube	
2110	0583 8100 66	1	Coupling	
2115	0581 0000 43	1	Pipe coupling	
	1624 2950 80	1	ED 12	
3010	0583 8120 73	• 1	Fitting pipe	
3020		• 1	Automatic drain	
3030	0663 9096 00	• 1	O-ring	
3040	1624 9233 00	• 1	Label	
3060	0583 8120 74	• 1	Fitting pipe	
3070	0607 1151 07	• 1	Reducing socket	
3080	1624 9357 00	• 1	Label	
4010		1	Hose assembly	
	0575 0125 54		GA 15 VSD	
	0575 0125 68		GA 18 VSD	
	0575 0125 68		GA 22 VSD	
	0575 0125 68		GA 26 VSD	
	0575 0125 68		GA 30 VSD	
4015	1622 2733 00	1	Connector	
4020	0215 0006 14	2	Screw	
4025		1	Nipple	
	0571 0036 31		GA 15 VSD	
	0571 0036 01		GA 18 VSD	
	0571 0036 01		GA 22 VSD	
	0571 0036 01		GA 26 VSD	
	0571 0036 01		GA 30 VSD	
4030	0663 3130 00	1	O-ring	
4035	0697 9810 32	1	Plug	

4

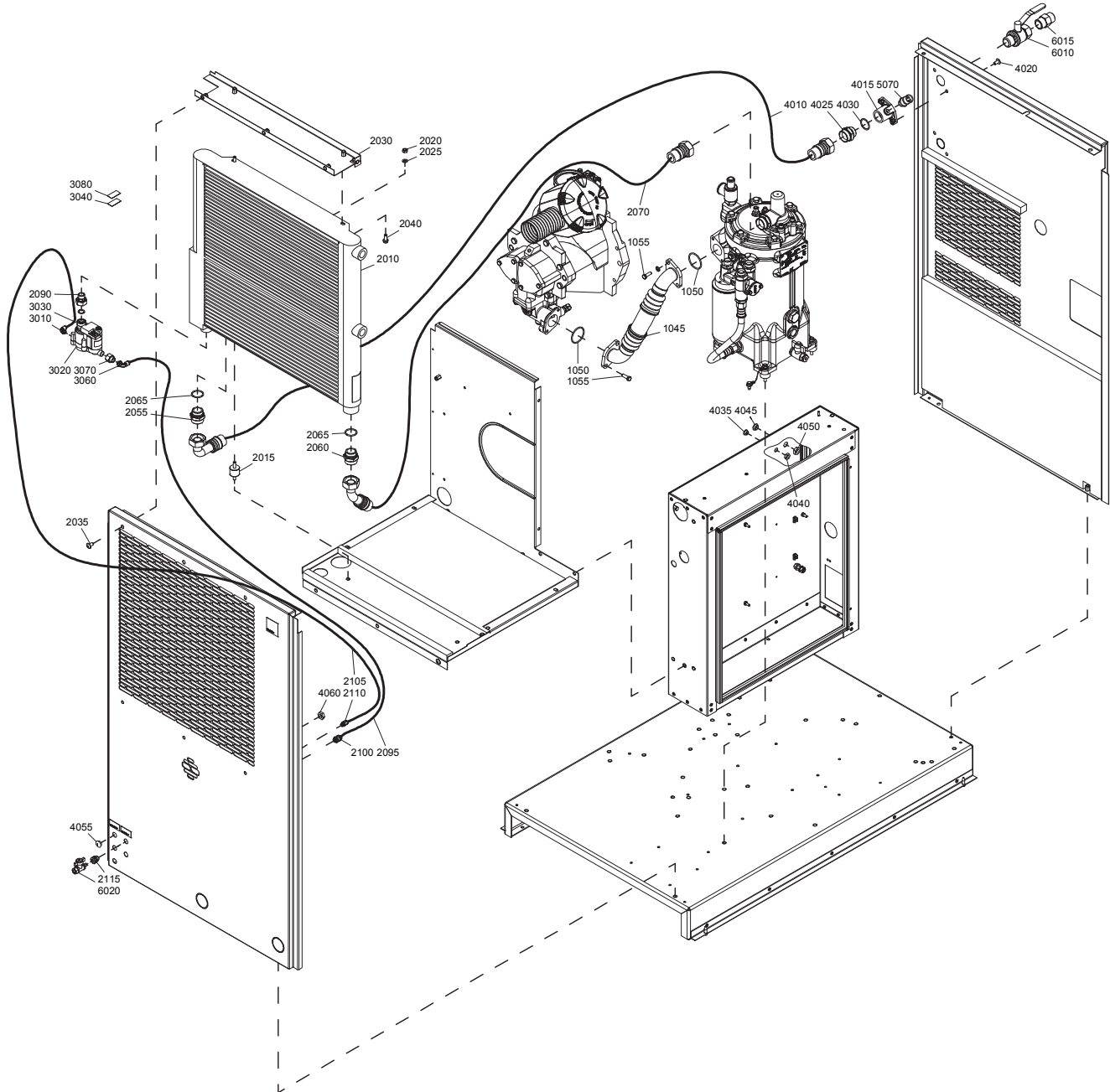

Air system - Air outlet and drains - Pack**4**

Ref.	Part number	Qty	Name	Remarks
4040	0697 9809 30	1	Lock nut	
4045	0697 9810 25	1	Plug	
4050	0697 9809 20	1	Lock nut	
4055	0697 9810 25	3	Plug	
4060	0697 9809 20	3	Lock nut	
5070	1089 0575 54	1	Press. transducer	
6010	0852 0011 02	1	Ball valve	
6015		1	Adaptor	
	0603 4100 25		ASME	
6020	0852 0010 55	1	Ball valve	

5

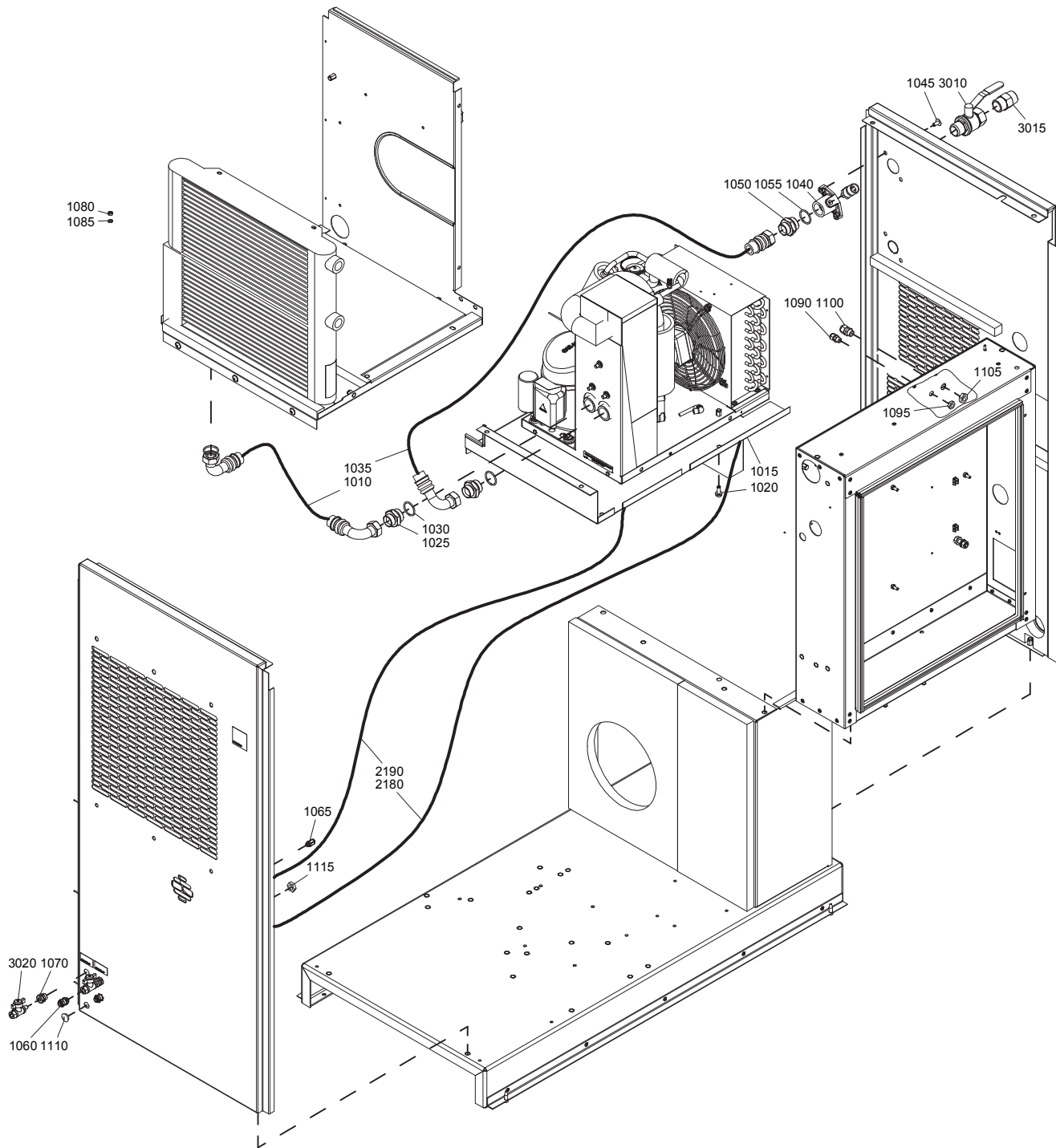

Air system - Air outlet and drains - Full Feature - GA 15 VSD

5

Ref.	Part number	Qty	Name	Remarks
1010	0575 0366 29	1	Hose assembly	
1015	<<< >>>	1	Air dryer	
1020	0147 1963 08	3	Hexagon bolt	
1025	0571 0036 31	2	Nipple hexagon	
1030	0663 3130 00	2	O-ring	
1035	0575 0125 52	1	Hose assembly	
1040	1622 2733 00	1	Connector	
1045	0215 0006 14	2	Hexagon socket screw	
1050	0571 0036 31	1	Nipple	
1055	0663 3130 00	1	O-ring	
1060	0583 8100 70	1	Fitting pipe	
1065	0583 8100 66	1	Fitting	
1070	0581 0000 43	1	Coupling	
1080	0266 2108 00	2	Nut	
1085	0301 2321 00	2	Washer	
1090	0698 5140 70	1	Cable gland	
1095	0697 9809 30	1	Lock nut	
1100	0698 5140 71	1	Cable gland	
1105	0697 9809 20	1	Lock nut	
1110	0697 9810 25	1	Plug	
1115	0697 9809 20	1	Lock nut	
2180	0070 6002 05	AR	Plastic tube	
2190	0070 6002 04	AR	Plastic tube	
3010	0852 0011 02	1	Ball valve	
3015		1	Adaptor	
	0603 4100 25		ASME	
3020	0852 0010 55	1	Ball valve	

6

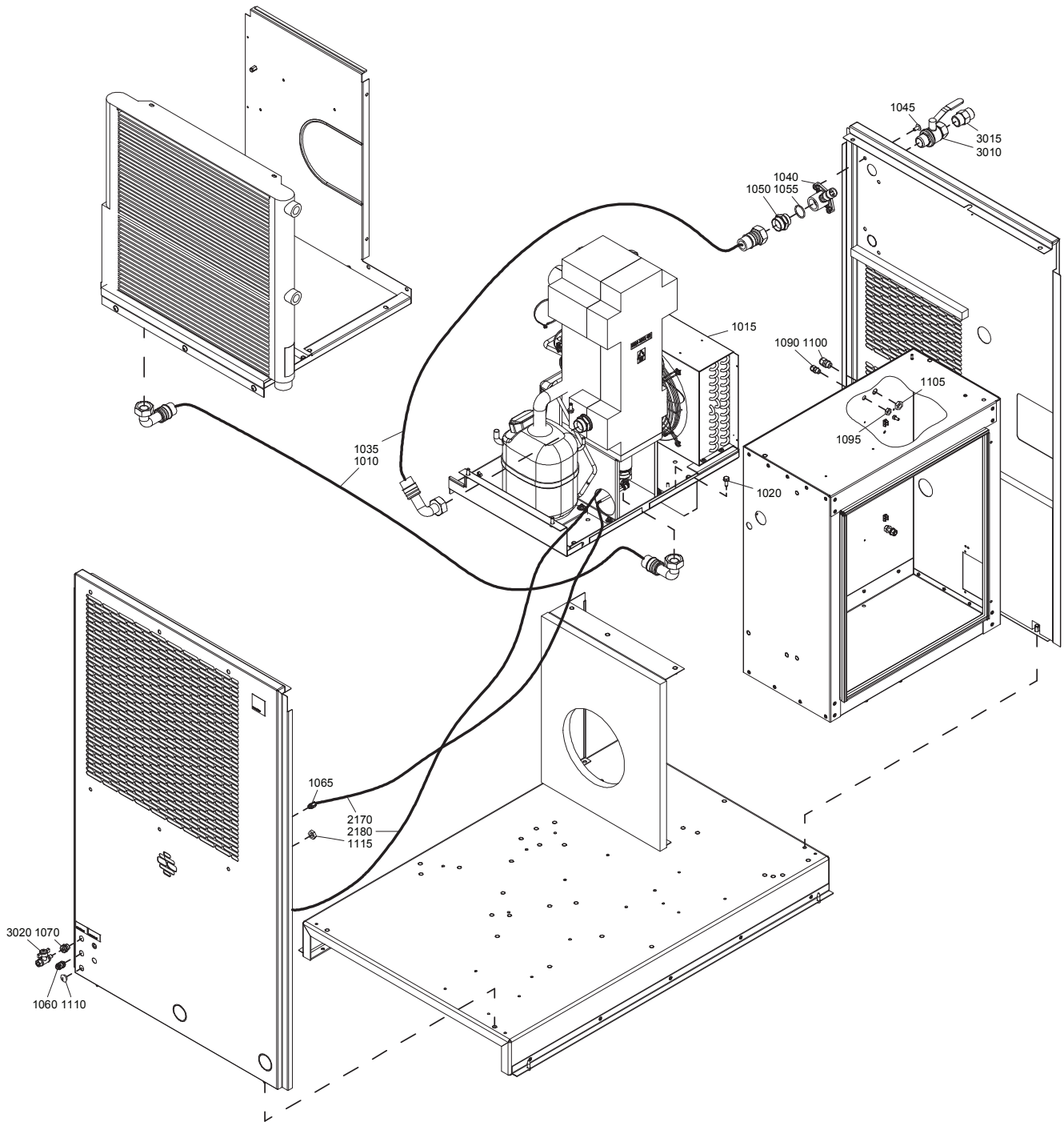

Air system - Air outlet and drains - Full Feature - GA 18 VSD, GA 22 VSD, GA 26 VSD, GA 30 VSD

6

Ref.	Part number	Qty	Name	Remarks
1010	0574 9914 25	1	Hose assembly	
1015	<<< >>>	1	Air dryer	
1020	0147 1963 08	3	Hexagon bolt	
1035	0574 9911 43	1	Hose assembly	
1040	1622 2733 00	1	Connector	
1045	0215 0006 14	2	Hexagon socket screw	
1050	0571 0036 01	1	Nipple	
1055	0663 3130 00	1	O-ring	
1060	0583 8100 70	1	Fitting pipe	
1065	0583 8100 66	1	Fitting	
1070	0581 0000 43	1	Coupling	
1090	0698 5140 70	1	Cable gland	
1095	0698 5140 71	1	Lock nut	
1100	0698 5140 71	1	Cable gland	
1105	0697 9809 20	1	Lock nut	
1110	0697 9810 25	1	Plug	
1115	0697 9809 20	1	Lock nut	
2180	0070 6002 04	2	Plastic tube	
2190	0070 6002 05	2	Plastic tube	
3010	0852 0011 02	1	Ball valve	
3015		1	Adaptor	
	0603 4100 25		ASME	
3020	0852 0010 55	1	Ball valve	

7

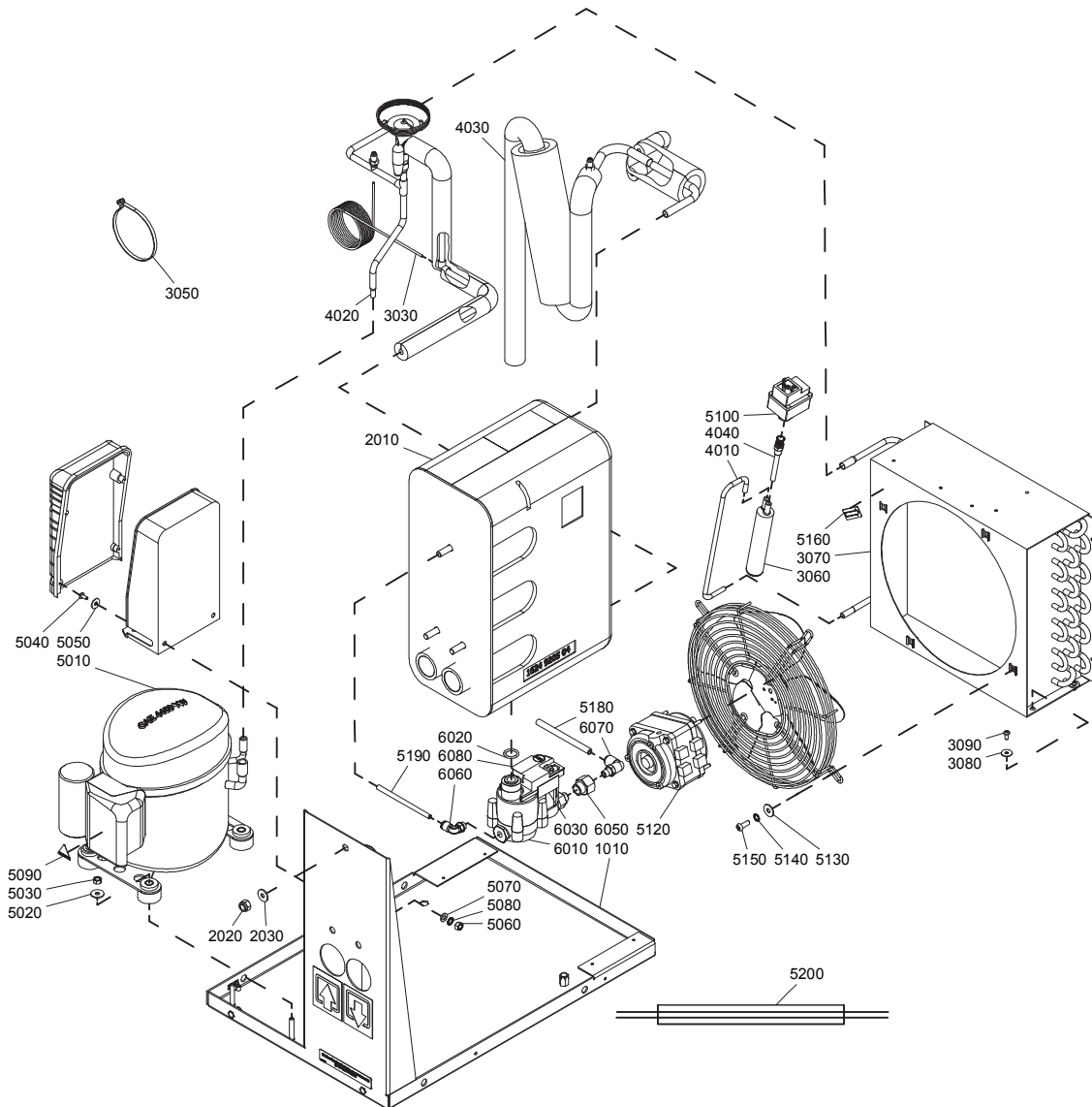

Air system - Air dryer - Full Feature - GA 15 VSD

7

Ref.	Part number	Qty	Name	Remarks
		1	Air dryer	
	8092 2883 91		ID 46 200V/50Hz IEC	
	8092 2884 17		ID 46 200V/60Hz UL-cUL	
	8092 2883 83		ID 46 230V/50Hz IEC	
	8092 2884 09		ID 46 230V/60Hz UL-cUL	
1010	1624 2977 80	• 1	Frame assy	
2010	1624 9111 80	• 1	Heat exchanger	
2020	0291 1128 18	• 3	Lock nut	
2030	0301 2335 00	• 3	Washer	
3030	1624 9078 80	• 1	Capillary	
3040	0017 9862 67	• AR	Tape	
3050	0348 0101 13	• AR	Cable tie	
3060	1617 2996 01	• 1	Filter dryer	
3070	2202 7351 02	• 1	Condensor	
3080	0300 0274 70	• 3	Washer	
3090	0226 3256 00	• 3	Screw	
4010	1624 9282 00	• 1	Pipe	
4020	1624 9198 00	• 1	Pipe	
	1619 5563 07	•• 1	Schröder valve	
	1624 2906 00	•• 1	Expansion valve	
4030	1624 9199 00	• 1	Pipe	
	1619 5563 07	•• 1	Schröder valve	
4040	1619 5563 06	• 1	Schröder valve	
5010	1617 3460 11	• 1	Compressor	
	1617 1549 02	•• 1	Start capacitor	
	1617 1874 05	•• 1	Run capacitor	
	1617 1551 28	•• 1	Start relay	
	1617 1550 91	•• 1	Overload protector	
	1617 1530 80	•• 1	Anti vibration mounting set	
5020		• 4	Washer	
	0300 0274 64		ID 46 200V	
	0301 2321 00		ID 46 230V	
5030	0266 2108 00	• 4	Nut	
5040	0226 3256 00	• 2	Screw	
5050	0300 0274 70	• 2	Washer	
5060	0266 2108 00	• 1	Nut	
5070	0301 2321 00	• 1	Washer	
5080	0333 3220 00	• 2	Washer	
5090	1088 1001 01	• 4	Warning mark	
5100	1624 9235 00	• 1	Switch press	
5110	1624 9034 00	• 1	Motor fan	
5120		• 4	Washer	
	0301 2321 00		ID 46 200V	
	0300 0274 64		ID 46 230V	
5130	0333 3220 00	• 4	Washer	
5140	0215 0003 91	• 4	Screw	
5150	1617 2385 00	• 1	Rotation arrow	
5190	1624 9051 00	• 1	Wiring	
5200	9827 9775 00	• 1	Service diagram	
5220	1617 0128 00	• 1	Heat conducting pasta	
		1	ED 12	
	1624 9332 80		200V/50-60Hz	
	1624 9049 80		230V/50-60Hz	
6010	0583 8120 73	• 1	Elbow coupling	

7

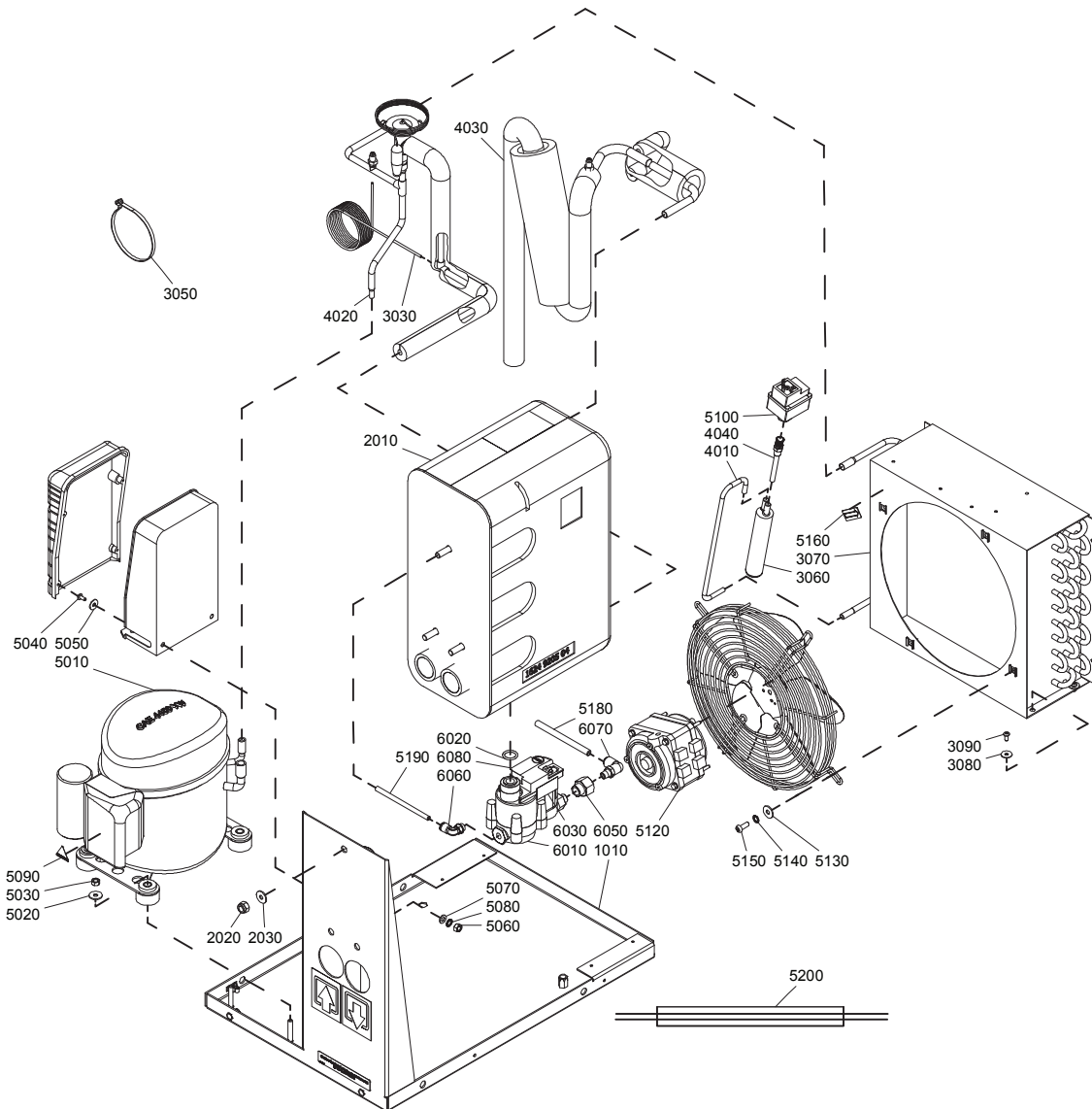

Air system - Air dryer - Full Feature - GA 15 VSD**7**

Ref.	Part number		Qty	Name	Remarks
6020		•	1	Drain	
6030	0663 9096 00	•	1	O-ring	
6050	0583 8120 74	•	1	Elbow coupling	
6060	0607 1151 07	•	1	Reducing socket	
6070		•	1	Label	
	1624 9359 00			200V	
	1624 9358 00			230V	

8

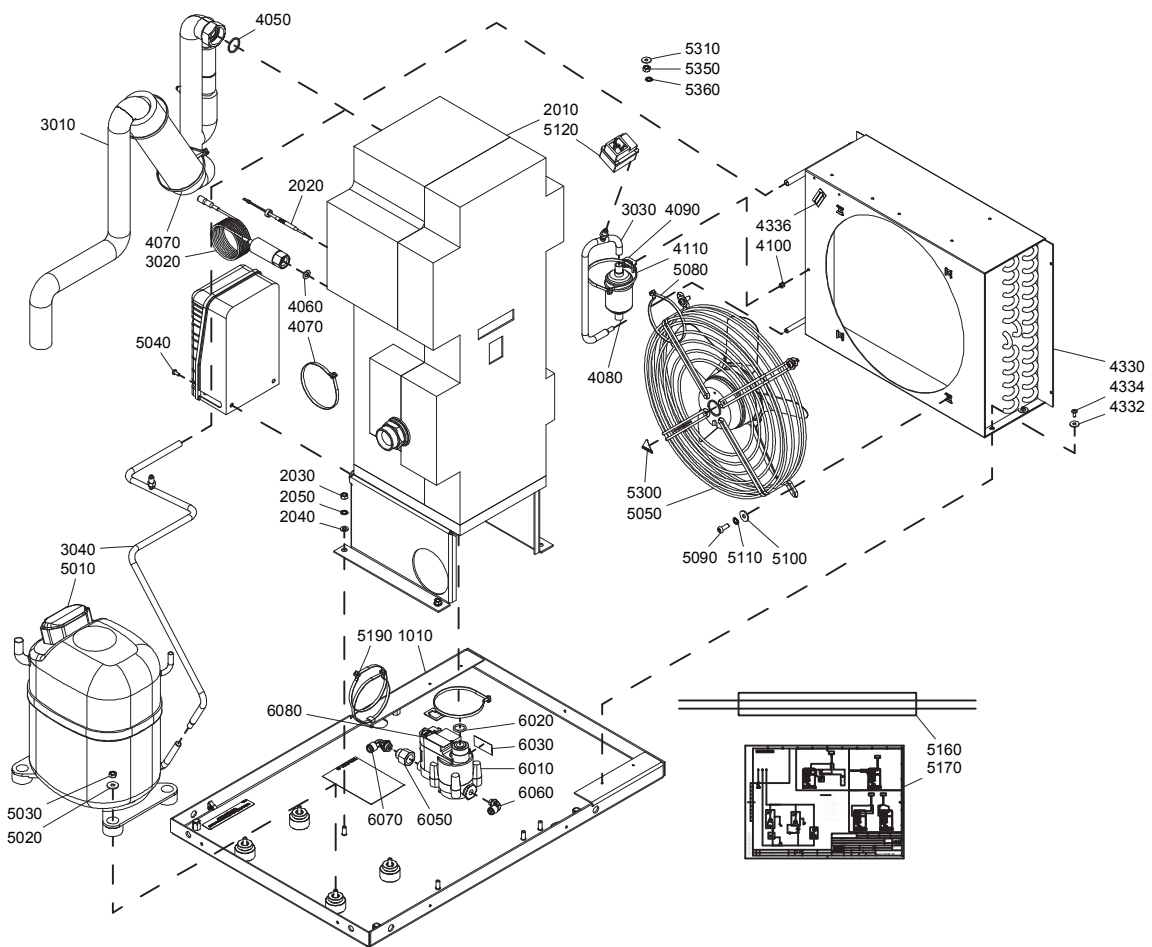

Air system - Air dryer - Full Feature - GA 18 VSD, GA 22 VSD, GA 26 VSD, GA 30 VSD

8

Ref.	Part number	Qty	Name	Remarks
		1	Air dryer	
	8092 2884 25		GA 18 VSD - ID 60 230V/50Hz IEC	
	8092 2884 33		GA 18 VSD - ID 60 230V/60Hz UL-cUL	
	8092 2884 58		GA 18 VSD - ID 71 200V/50Hz IEC	
	8092 2884 74		GA 18 VSD - ID 71 200V/60Hz UL-cUL	
	8092 2884 33		GA 18 VSD - ID 60 380V/60Hz UL-cUL	
	8092 2884 25		GA 18 VSD - ID 60 400V+N/50Hz IEC	
	8092 2884 33		GA 18 VSD - ID 60 460V/60Hz UL-cUL	
	8092 2884 25		GA 18 VSD - ID 60 500V/50Hz IEC	
	8092 2884 33		GA 18 VSD - ID 60 575V/60Hz UL-cUL	
	8092 2884 58		GA 22 VSD - ID 71 200V/50Hz IEC	
	8092 2884 74		GA 22 VSD - ID 71 200V/60Hz UL-cUL	
	8092 2884 41		GA 22 VSD - ID 71 230V/50Hz IEC	
	8092 2884 66		GA 22 VSD - ID 71 230V/60Hz UL-cUL	
	8092 2884 66		GA 22 VSD - ID 71 380V/60Hz UL-cUL	
	8092 2884 41		GA 22 VSD - ID 71 400V+N/50Hz IEC	
	8092 2884 66		GA 22 VSD - ID 71 460V/60Hz UL-cUL	
	8092 2884 41		GA 22 VSD - ID 71 500V/50Hz IEC	
	8092 2884 66		GA 22 VSD - ID 71 575V/60Hz UL-cUL	
	8092 2884 90		GA 26 VSD - ID 93 200V/50Hz IEC	
	8092 2885 16		GA 26 VSD - ID 93 200V/60Hz UL-cUL	
	8092 2884 82		GA 26 VSD - ID 93 230V/50Hz IEC	
	8092 2885 08		GA 26 VSD - ID 93 230V/60Hz UL-cUL	
	8092 2885 08		GA 26 VSD - ID 93 380V/60Hz UL-cUL	
	8092 2884 82		GA 26 VSD - ID 93 400V+N/50Hz IEC	
	8092 2885 08		GA 26 VSD - ID 93 460V/60Hz UL-cUL	
	8092 2884 82		GA 26 VSD - ID 93 500V/50Hz IEC	
	8092 2885 08		GA 26 VSD - ID 93 575V/60Hz UL-cUL	
	8092 2884 90		GA 30 VSD - ID 93 200V/50Hz IEC	
	8092 2885 16		GA 30 VSD - ID 93 200V/60Hz UL-cUL	
	8092 2884 82		GA 30 VSD - ID 93 230V/50Hz IEC	
	8092 2885 08		GA 30 VSD - ID 93 230V/60Hz UL-cUL	
	8092 2885 08		GA 30 VSD - ID 93 380V/60Hz UL-cUL	
	8092 2884 82		GA 30 VSD - ID 93 400V+N/50Hz IEC	
	8092 2885 08		GA 30 VSD - ID 93 460V/60Hz UL-cUL	
	8092 2884 82		GA 30 VSD - ID 93 500V/50Hz IEC	
	8092 2885 08		GA 30 VSD - ID 93 575V/60Hz UL-cUL	
1010	1624 2886 80	• 1	Frame	
2010		• 1	Heat exchanger	
	1624 2907 80		ID 60	
	1624 2908 80		ID 71	
	1624 2909 80		ID 93	
2020	1624 9803 00	• 1	Temp. sensor	
2030	0266 2108 00	• 4	Nut	
2040	0300 0274 64	• 4	Washer	
2050	0333 3220 00	• 4	Washer	
2060	1617 0128 00	• AR	Heat conducting pasta	
3010		• 1	Pipe assy	
	1624 2932 00		ID 60 230V/50HZ	
	1624 2932 00		ID 60 230V/60HZ	
	1624 9331 00		ID 71 200V/50HZ	
	1624 2932 00		ID 71 230V/60HZ	
	1624 2912 00		ID 93 200V/50Hz	
	1624 2912 00		ID 93 230V/60HZ	

8

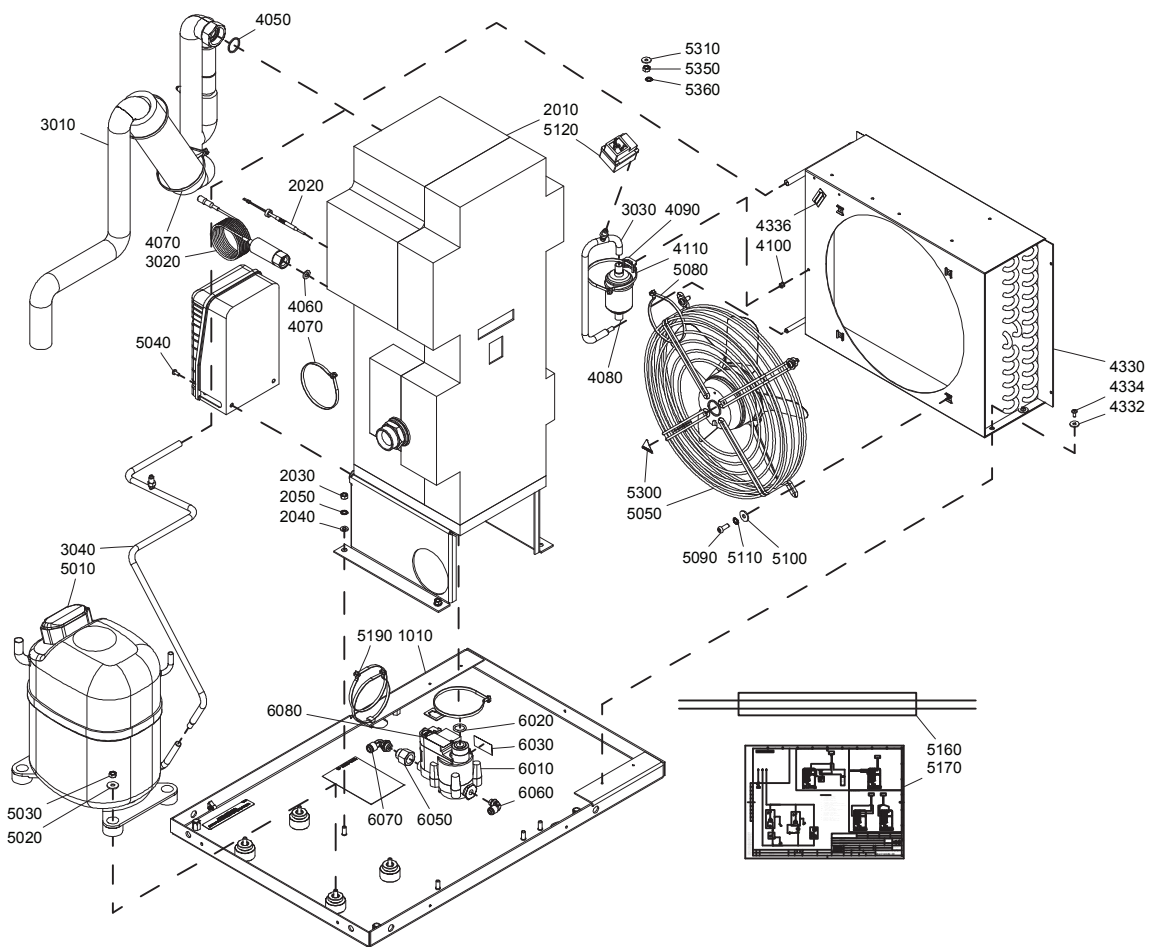

Air system - Air dryer - Full Feature - GA 18 VSD, GA 22 VSD, GA 26 VSD, GA 30 VSD

8

Ref.	Part number	Qty	Name	Remarks
	1624 2906 00	•• 1	Valve	
	1617 1898 00	•• 1	Sleeve	
	1617 0314 00	•• 1	Nut	
	1619 5563 07	•• 1	Schrader valve	
3020		• 1	Capillary	
	1624 2934 00		ID 60	
	1624 2934 00		ID 71	
	1624 2938 00		ID 71	
	1624 2919 00		ID 93	
3030	1624 2913 00	• 1	Pipe assy	
	1619 5563 07	•• 1	Schrader valve	
3040		• 1	Pipe assy	
	1624 2946 00		ID 71 200V/50HZ	
	1624 2918 00		ID 93 200V/50Hz	
	1624 2918 00		ID 93 230V/60HZ	
	1619 5563 07	•• 1	Valve schrader	
4040	0017 9862 67	• AR	Tape	
4050	1617 0315 00	• AR	Ring	
4060	1617 0092 03	• 1	Ring	
4070	0348 0101 13	• 6	Cable tie	
4080	1624 2465 00	• 1	Filter dryer	
4090	0348 0110 03	• 1	Anchor plate	
4100	0129 3270 40	• 1	Rivetto strappo	
4110	0348 0101 13	• 1	Cable tie	
4330	2202 7352 01	• 1	Condensor	
4332	0300 0274 70	• 3	Washer	
4334	0226 3256 00	• 3	Screw	
4336	1617 2385 00	• 1	Rotation arrow	
5010		• 1	Refrigerant compressor	
	1617 1494 30		ID 60 230V/50Hz	
	1617 1494 28		ID 60 230V/60Hz	
	1617 1494 14		ID 71 200V/50Hz	
	1617 1494 28		ID 71 200V/60Hz	
	1617 1494 01		ID 71 230V/50Hz	
	1617 1494 28		ID 71 230V/60Hz	
	1617 1494 17		ID 93 200V/50Hz	
	1617 1494 18		ID 93 200V/60Hz	
	1617 1494 16		ID 93 230V/50Hz	
	1617 1494 18		ID 93 230V/60Hz	
		•• 1	Start capacitor	
	1617 1549 01		1617 1494 01	
	1617 1549 05		1617 1494 14	
	1617 1549 10		1617 1494 16	
	1617 1549 05		1617 1494 17	
	1617 1549 11		1617 1494 18	
	1617 1549 02		1617 1494 28	
	1617 1549 02		1617 1494 30	
		•• 1	Run capacitor	
	1617 1874 01		1617 1494 16	
	1617 1874 01		1617 1494 17	
	1617 1874 01		1617 1494 18	

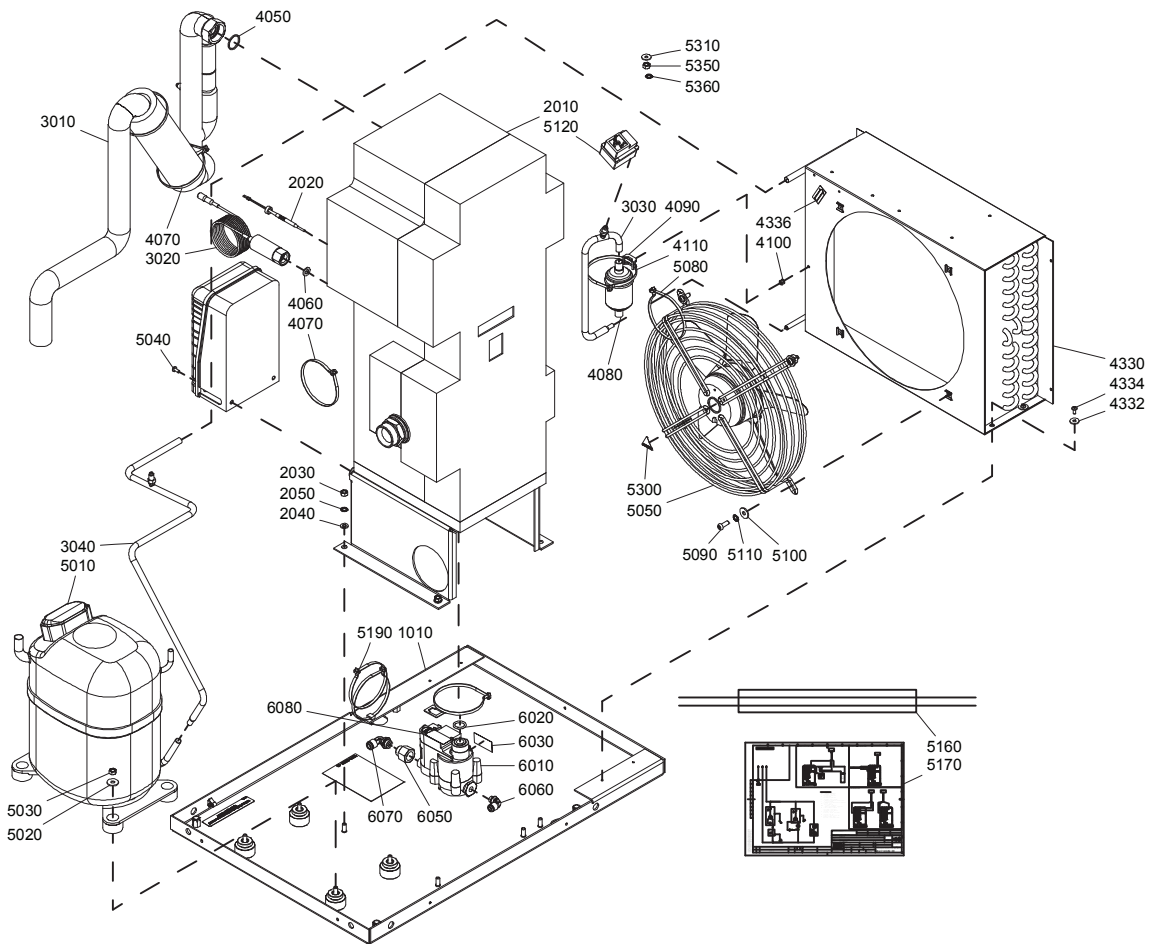

Air system - Air dryer - Full Feature - GA 18 VSD, GA 22 VSD, GA 26 VSD, GA 30 VSD

8

Ref.	Part number	Qty	Name	Remarks
		•• 1	Start relay	
	1617 1551 27		1617 1494 01	
	1617 1551 13		1617 1494 14	
	1617 1551 28		1617 1494 16	
	1617 1551 29		1617 1494 17	
	1617 1551 29		1617 1494 18	
	1617 1551 13		1617 1494 28	
	1617 1551 71		1617 1494 30	
		•• 1	Overload protector	
	1617 1551 14		1617 1494 01	
	1617 1550 24		1617 1494 14	
	1617 1550 30		1617 1494 16	
	1617 1550 31		1617 1494 17	
	1617 1550 32		1617 1494 18	
	1617 1550 86		1617 1494 28	
	1617 1550 85		1617 1494 30	
	1617 1530 80	•• 1	Anti vibration mounting set	
5020	0300 0274 64	• 4	Washer	
5030	0266 2108 00	• 4	Nut	
5040	0226 3256 00	• 2	Screw	
5050		• 1	Fan axial	
	1624 9349 00		ID 60 230V/50Hz	
	2202 7373 05		ID 60 230V/60Hz	
	1624 9349 00		ID 71 200V/50Hz	
	2202 7373 05		ID 71 200V/60Hz	
	1624 9349 00		ID 71 230V/50Hz	
	2202 7373 05		ID 71 230V/60Hz	
	1624 2917 84		ID 93 200V/50Hz	
	1624 2917 85		ID 93 200V/60Hz	
	1624 2917 84		ID 93 230V/50Hz	
	1624 2917 85		ID 93 230V/60Hz	
5080	0348 0101 13	• 1	Cable tie	
5090	0215 0003 91	• 4	Screw	
5100	0300 0274 64	• 4	Washer	
5110	0333 3220 00	• 4	Washer	
5120	1624 9235 00	• 1	Switch press	
5160	1624 9014 00	• 1	Wiring	
5170		1	Service diagram	
	9827 9689 00		ID 60 230V/50Hz	
	9827 9689 00		ID 60 230V/60Hz	
	9827 9689 00		ID 71 230V/50Hz	
	9827 9689 00		ID 71 230V/60Hz	
	9827 9688 00		ID 93 230V/50Hz	
	9827 9688 00		ID 93 230V/60Hz	
5190	0348 0101 13	• 1	Cable tie	
5300	1088 1001 01	• 4	Warning mark	
5310	0300 0274 70	• 2	Washer	
5350	0266 2108 00	• 1	Nut	
5360	0333 3220 00	• 2	Washer	
		1	ED 12	
	1624 9332 80		200V/50-60Hz	
	1624 9049 80		230V/50-60Hz	
6010	0583 8120 73	• 1	Elbow coupling	

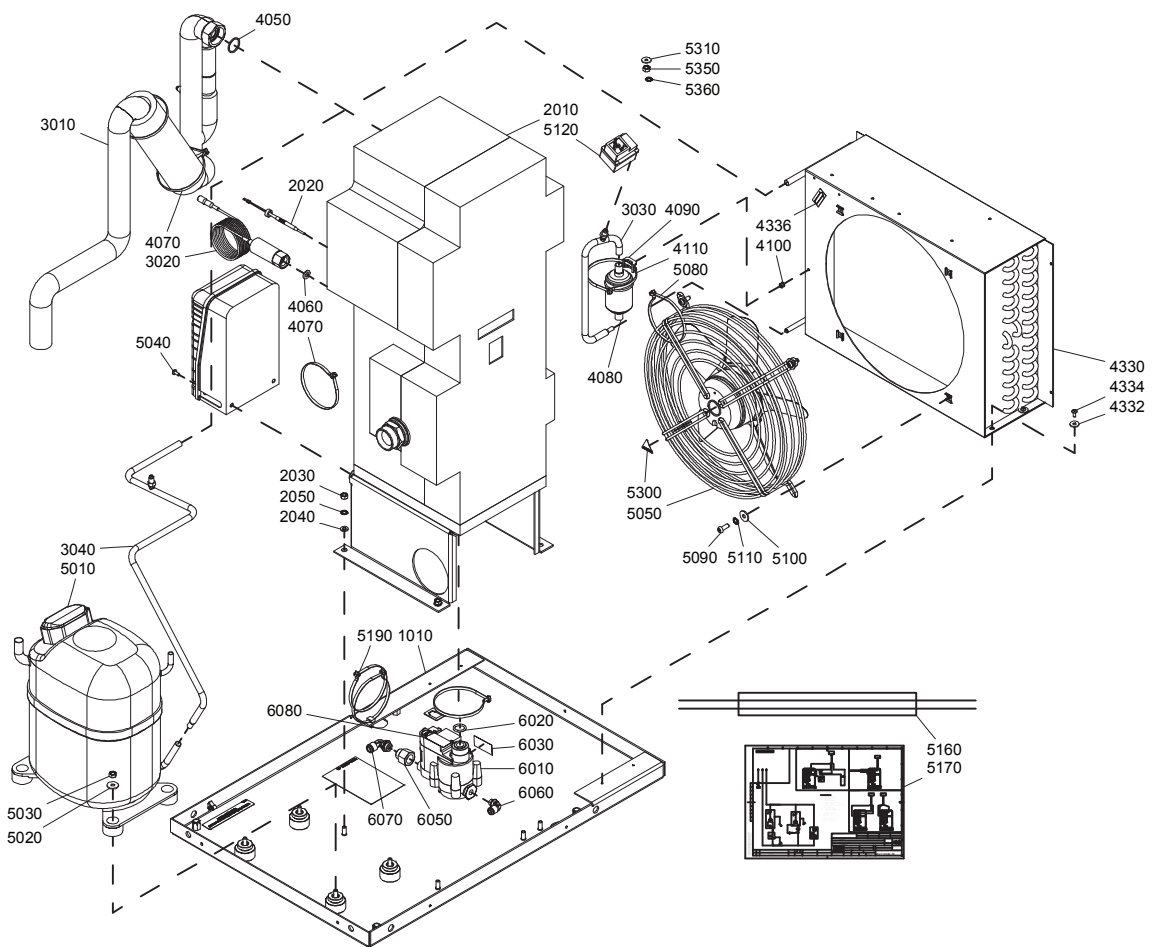

**Air system - Air dryer - Full Feature - GA 18 VSD, GA 22 VSD,
GA 26 VSD, GA 30 VSD****8**

Ref.	Part number		Qty	Name	Remarks
6020		•	1	Drain	
6030	0663 9096 00	•	1	O-ring	
6040		•	1	Label	
	1624 9333 00			200V	
	1624 9234 00			230V	
6050	0583 8120 74	•	1	Elbow coupling	
6060	0607 1151 07	•	1	Reducing socket	
6070		•	1	Label	
	1624 9359 00			200V	
	1624 9358 00			230V	

9

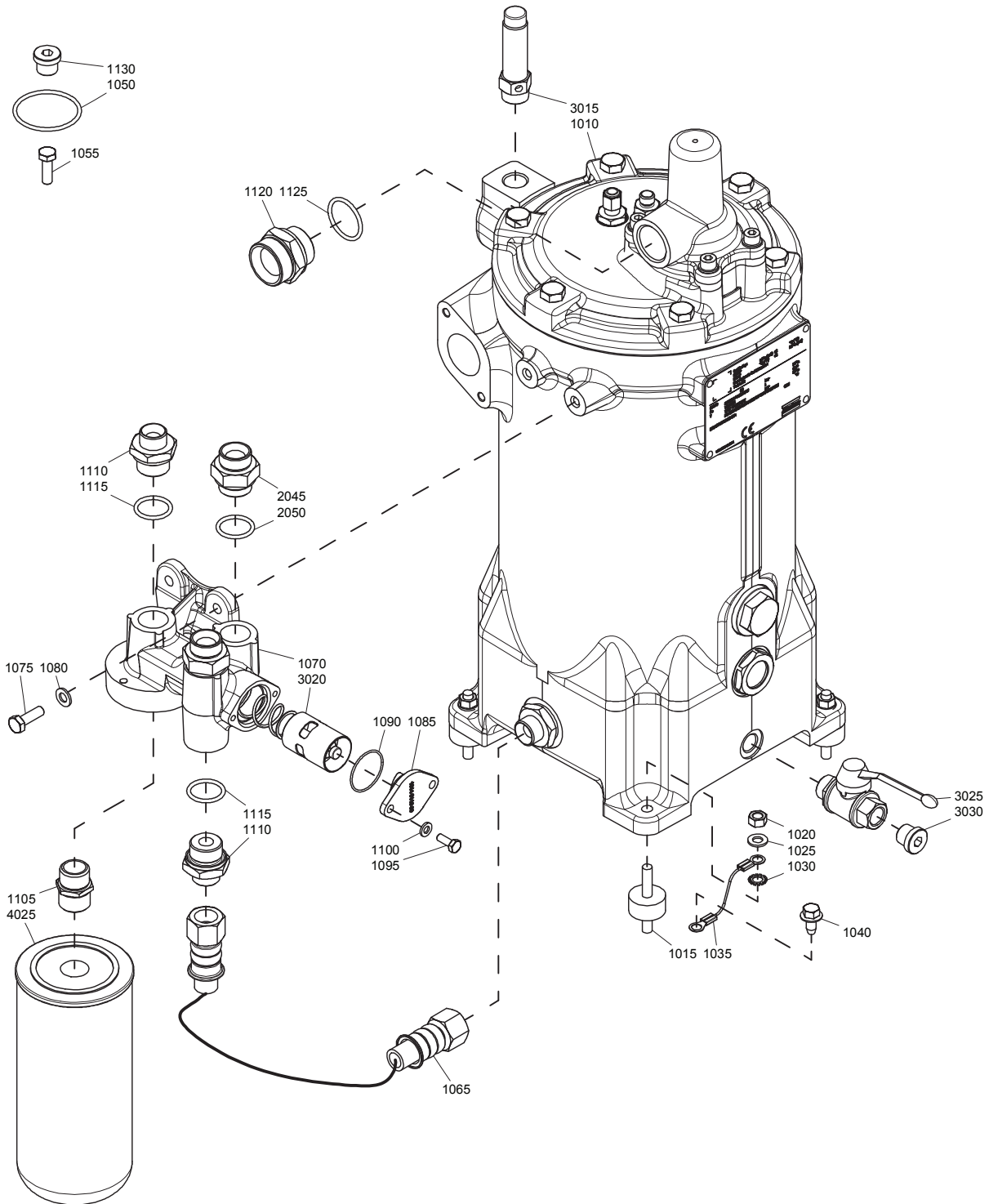

Oil system - Oil separator module

9

Ref.	Part number	Qty	Name	Remarks
1010	<<< >>>	1	Air receiver	
1015	2235 2544 00	4	Damper	
1020	0266 2110 00	4	Nut	
1025	0301 2335 00	4	Washer	
1030	0333 3227 00	1	Lock washer	
1035	1613 8967 12	1	Grounding of vessel	
1040	0226 0301 00	1	Screw	
1065	0574 9910 10	1	Hose assembly	
1070	1622 2728 01	1	Oil filter housing	
1075	0147 1325 03	2	Hexagon bolt	
1080	0301 2335 00	2	Washer	
1085	1614 6118 00	1	Flange	
1090	0663 2101 95	1	O-ring	
1095	0147 1246 03	2	Hexagon bolt	
1100	0301 2321 00	2	Washer	
1105	1619 3770 00	1	Nipple	
1110	0571 0035 97	2	Nipple	
1115	0663 2113 37	2	O-ring	
1120	0571 0036 01	1	Nipple	
1125	0663 3130 00	1	O-ring	
1130	0686 3718 16	1	Plug	
2045		2	Nipple	
	0571 0035 97		GA 15 VSD	
	0571 0035 97		GA 18 VSD	
	0571 0035 97		GA 22 VSD	
	0571 0035 97		GA 26 VSD	
	0571 0035 99		GA 30 VSD	
2050	0663 2113 37	2	O-ring	
3015		1	Safety valve	
	0830 1010 03		13bar(e)	
	0830 1009 98		175psig	
3020		1	Thermostatic valve	
	1622 7064 01		13bar(e) 38°C	
	1622 7064 01		175psig 38°C	
3025	0852 0010 31	1	Ball valve	
3030	0686 3718 16	1	Plug	
4025		1	Oil filter	
	1622 7836 00		Roto-Inject Fluid	
	1622 7836 00		Foodgrade Fluid	
	1622 7837 00		Roto-Xtend Duty Fluid	

10

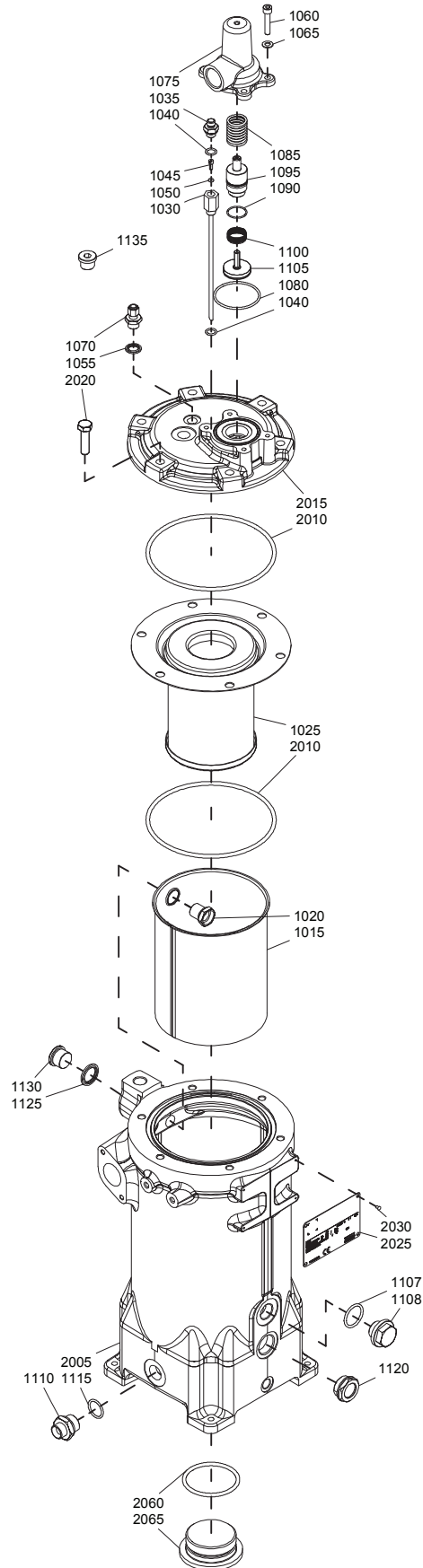

Oil system - Air receiver/Oil vessel

10

Ref.	Part number	Qty	Name	Remarks
		1	Air receiver	
	1622 6996 99		ASME	
	1622 6996 99		CE	
	1622 6996 95		MOM	
1015	1622 6920 00	• 1	Shield	
1020	1622 5078 00	• 1	Nipple	
1025	1625 7036 00	• 1	Separator	
1030	1625 7038 00	• 1	Scavenge line	
1035	1622 4867 00	• 1	Nipple	
1040	0663 3119 00	• 2	O-ring	
1045	1613 9005 01	• 1	Non return valve	
1050	0663 2108 11	• 1	O-ring	
1055	0661 1000 40	• 1	Seal washer	
1060	0211 1102 19	• 4	Screw	
1065	0301 2335 00	• 4	Washer	
1070	0581 0001 02	• 1	Nipple	
1075	1622 2737 00	• 1	Housing	
1080	0663 7137 00	• 1	O-ring	
1085	1622 0524 00	• 1	Spring	
1090	0663 2101 30	• 1	O-ring	
1095	1622 0522 01	• 1	Piston	
1100	1622 0525 00	• 1	Spring	
1105	1622 9078 80	• 1	Valve disk	
1107	0663 2102 15	• 1	O-ring	
1108	1202 8992 00	• 1	Plug	
1110	0571 0035 97	• 1	Nipple	
1115	0663 2113 37	• 1	O-ring	
1120	1513 0168 00	• 1	Sight glass	
1125	0661 1000 43	• 1	Seal washer	
1130	0686 6446 00	• 1	Plug	
1135	0686 3718 17	• 1	Plug	
		• 1	Vessel	
	1622 6912 99		ASME	
	1622 6912 99		CE	
	1622 6912 95		MOM	
2005		•• 1	Vessel	
2010	0663 2106 97	•• 2	O-ring	
2015	1622 6923 00	•• 1	Housing	
2020	0147 1107 91	•• 6	Hexagon bolt	
2025		•• 1	Data plate	
2030	0244 4184 00	•• 4	Drive screw	
2060	0663 2111 18	•• 1	O-ring	
2065	1622 0001 02	•• 1	Plug	

11

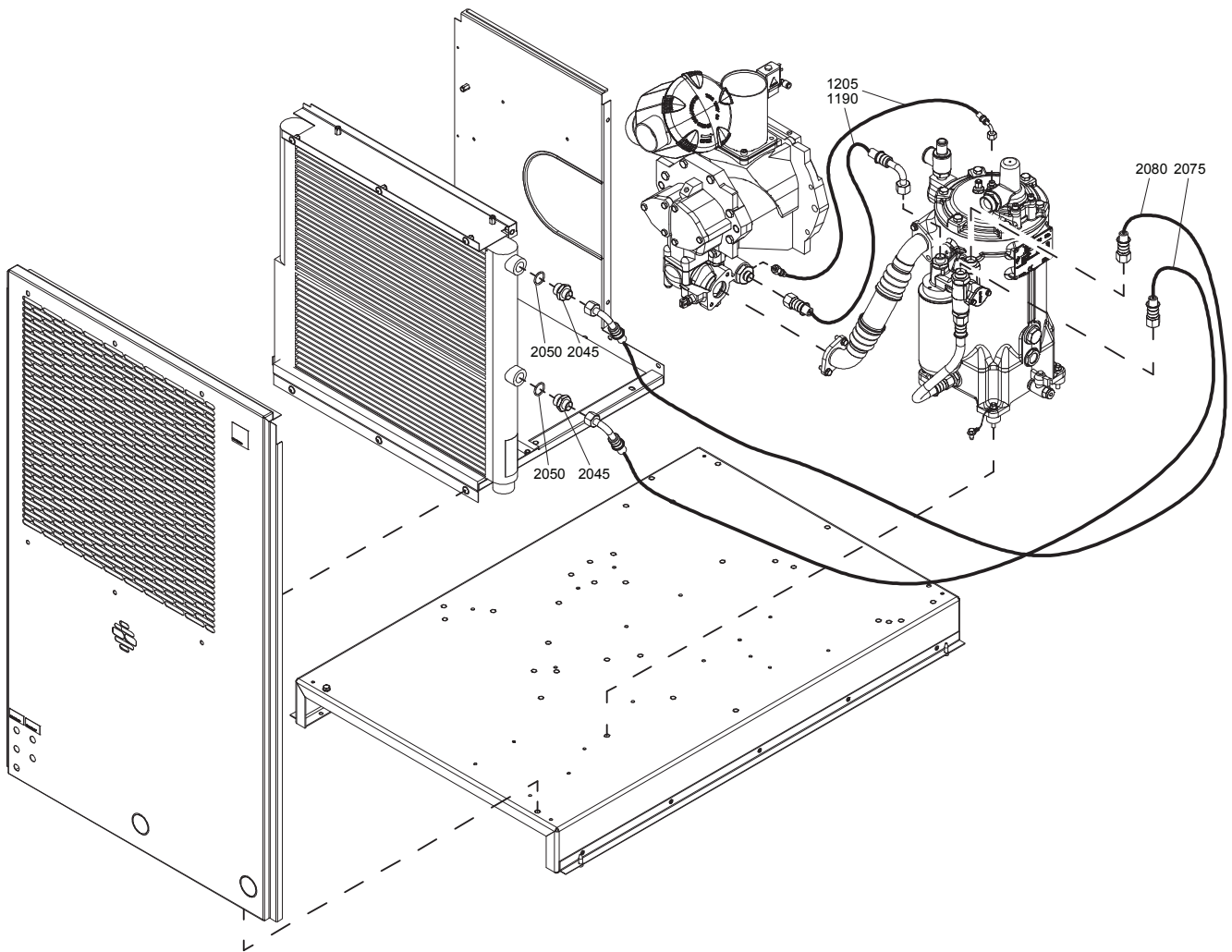

Oil system - Cooler connections

11

Ref.	Part number	Qty	Name	Remarks
1190	0574 9918 05	1	Hose assembly	
1205	0574 9911 01	1	Hose assembly	
2045		2	Nipple	
	0571 0035 97		GA 15 VSD	
	0571 0035 97		GA 18 VSD	
	0571 0035 97		GA 22 VSD	
	0571 0035 97		GA 26 VSD	
	0571 0035 99		GA 30 VSD	
2050	0663 2113 37	2	O-ring	
2075		1	Hose assembly	
	0574 9911 47		GA 15 VSD	
	0574 9911 14		GA 18 VSD	
	0574 9911 14		GA 22 VSD	
	0574 9911 14		GA 26 VSD	
	0574 9911 28		GA 30 VSD	
2080		1	Hose assembly	
	0574 9911 14		GA 15 VSD	
	0574 9911 46		GA 18 VSD	
	0574 9911 46		GA 22 VSD	
	0574 9911 46		GA 26 VSD	
	0574 9911 09		GA 30 VSD	

12

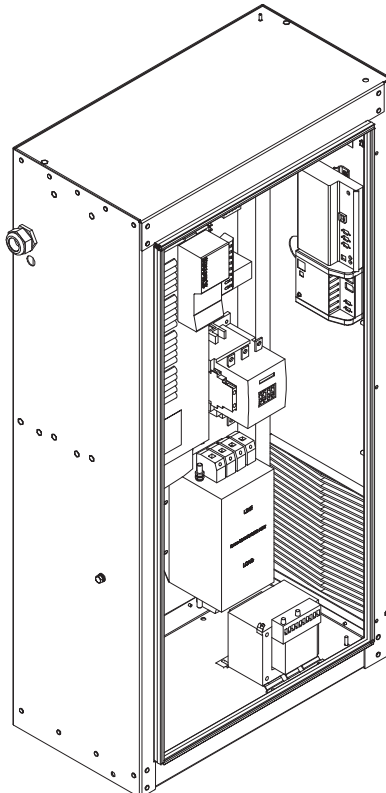
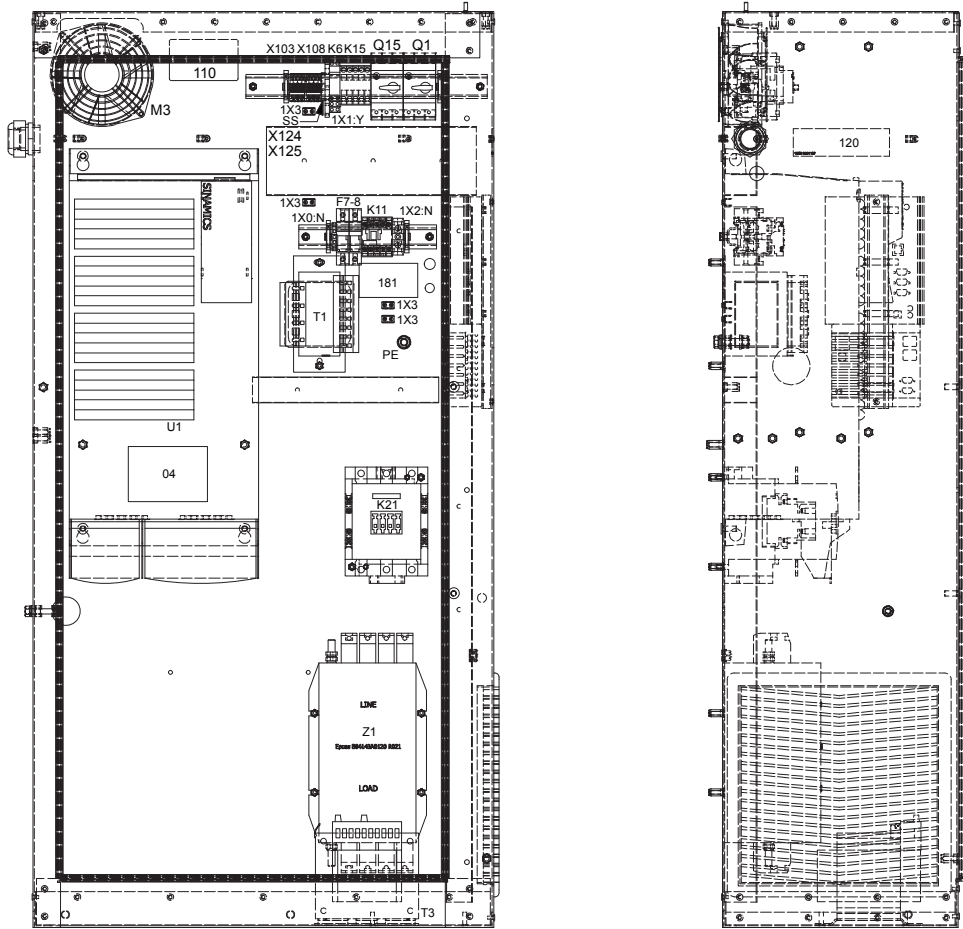

Cubicle - IEC/UL-cUL

12

Ref.	Part number	Qty	Name	Remarks
		1	Cubicle	
	1900 2228 11		GA 15 VSD 200V/50-60Hz	
	1900 2228 11		GA 15 VSD 230V/50-60Hz	
	1900 2228 01		GA 15 VSD 380V/50-60Hz	
	1900 2228 01		GA 15 VSD 460V/50-60Hz	
	1900 2228 41		GA 15 VSD 380V/50-60Hz IT version	
	1900 2228 41		GA 15 VSD 460V/50-60Hz IT version	
	1900 2228 21		GA 15 VSD 500V/50Hz IEC	
	1900 2228 51		GA 15 VSD 500V/50Hz IT version	
	1900 2228 31		GA 15 VSD 575V/60Hz UL-cUL	
	1900 2228 12		GA 18 VSD 200V/50-60Hz	
	1900 2228 12		GA 18 VSD 230V/50-60Hz	
	1900 2228 02		GA 18 VSD 380V/50-60Hz	
	1900 2228 02		GA 18 VSD 460V/50-60Hz	
	1900 2228 42		GA 18 VSD 380V/50-60Hz IT version	
	1900 2228 42		GA 18 VSD 460V/50-60Hz IT version	
	1900 2228 22		GA 18 VSD 500V/50Hz IEC	
	1900 2228 52		GA 18 VSD 500V/50Hz IT version	
	1900 2228 32		GA 18 VSD 575V/60Hz UL-cUL	
	1900 2228 13		GA 22 VSD 200V/50-60Hz	
	1900 2228 13		GA 22 VSD 230V/50-60Hz	
	1900 2228 03		GA 22 VSD 380V/50-60Hz	
	1900 2228 03		GA 22 VSD 460V/50-60Hz	
	1900 2228 43		GA 22 VSD 380V/50-60Hz IT version	
	1900 2228 43		GA 22 VSD 460V/50-60Hz IT version	
	1900 2228 23		GA 22 VSD 500V/50Hz IEC	
	1900 2228 53		GA 22 VSD 500V/50Hz IT version	
	1900 2228 33		GA 22 VSD 575V/60Hz UL-cUL	
	1900 2228 14		GA 26 VSD 200V/50-60Hz	
	1900 2228 04		GA 26 VSD 380V/50-60Hz	
	1900 2228 04		GA 26 VSD 460V/50-60Hz	
	1900 2228 44		GA 26 VSD 380V/50-60Hz IT version	
	1900 2228 44		GA 26 VSD 460V/50-60Hz IT version	
	1900 2228 24		GA 26 VSD 500V/50Hz IEC	
	1900 2228 54		GA 26 VSD 500V/50Hz IT version	
	1900 2228 34		GA 26 VSD 575V/60Hz UL-cUL	
	1900 2228 15		GA 30 VSD 200V/50-60Hz	
	1900 2228 05		GA 30 VSD 380V/50-60Hz	
	1900 2228 05		GA 30 VSD 460V/50-60Hz	
	1900 2228 45		GA 30 VSD 380V/50-60Hz IT version	
	1900 2228 45		GA 30 VSD 460V/50-60Hz IT version	
	1900 2228 25		GA 30 VSD 500V/50Hz IEC	
	1900 2228 55		GA 30 VSD 500V/50Hz IT version	
	1900 2228 35		GA 30 VSD 575V/60Hz UL-cUL	
-	1622 3919 13	• 1	Wire harness	
-	9820 5207 53	• 1	Assembly drawing	
-	9820 5207 25	• 1	Service diagram	
F35-F36-F37		• 3	Fuse	
	1089 0591 02		1900 2228 11	
	1089 0591 02		1900 2228 12	
	1089 0591 02		1900 2228 13	
	1089 0591 03		1900 2228 14	
	1089 0591 03		1900 2228 15	
	1089 0591 02		1900 2228 31	

12

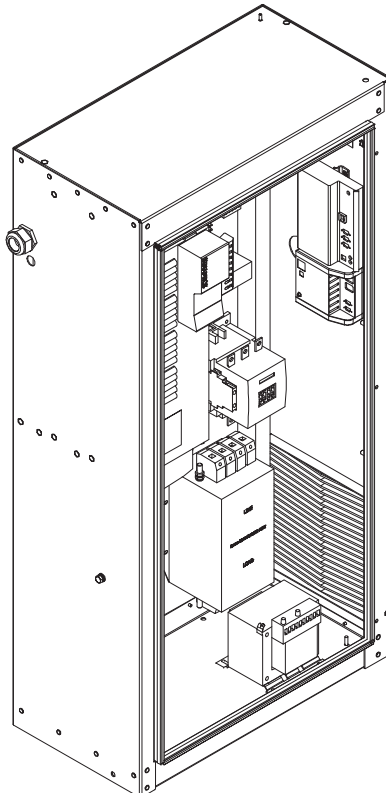
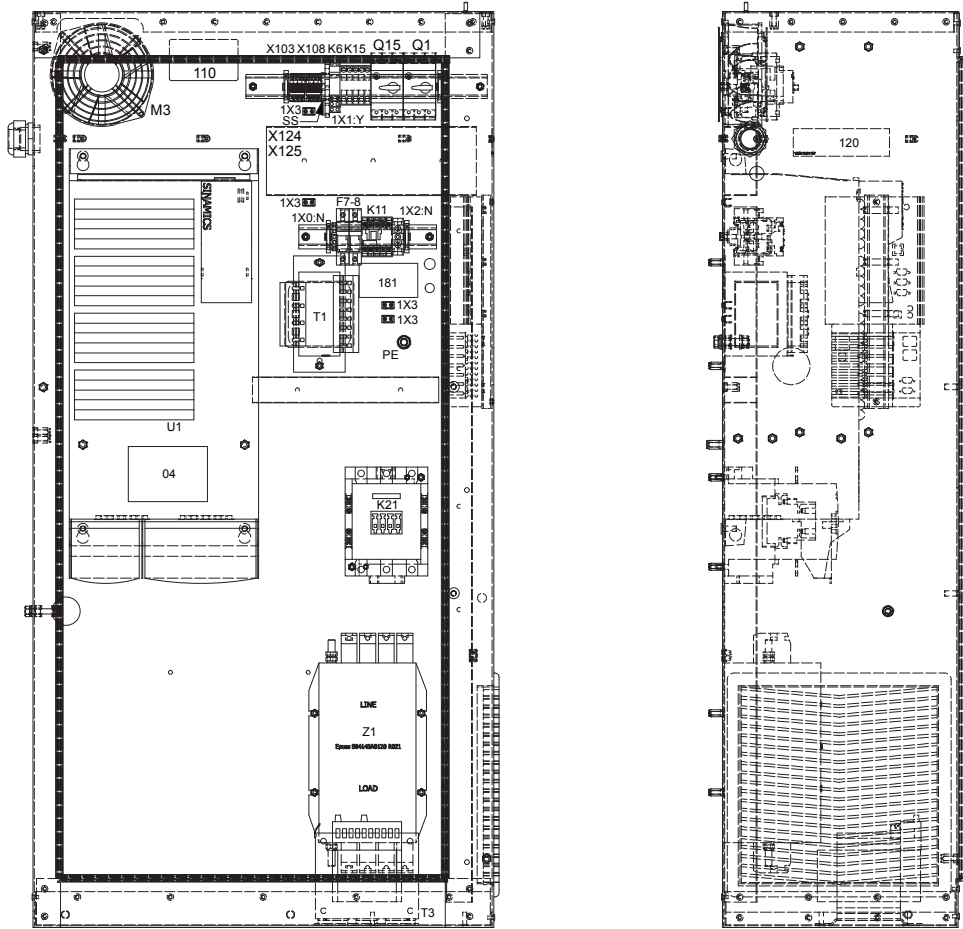

Cubicle - IEC/UL-cUL

12

Ref.	Part number	Qty	Name	Remarks
	1089 0591 02		1900 2228 32	
	1089 0591 02		1900 2228 33	
	1089 0591 02		1900 2228 34	
	1089 0591 02		1900 2228 35	
F35-F36-F37		• 3	Fuse cover	
	1089 0591 51		1900 2228 11	
	1089 0591 51		1900 2228 12	
	1089 0591 51		1900 2228 13	
	1089 0591 51		1900 2228 14	
	1089 0591 51		1900 2228 15	
	1089 0591 51		1900 2228 31	
	1089 0591 51		1900 2228 32	
	1089 0591 51		1900 2228 33	
	1089 0591 51		1900 2228 34	
	1089 0591 51		1900 2228 35	
F35-F36-F37		• 3	Fuse block	
	1089 9536 38		1900 2228 11	
	1089 9536 38		1900 2228 12	
	1089 9536 38		1900 2228 13	
	1089 9536 38		1900 2228 14	
	1089 9536 38		1900 2228 15	
	1089 9536 38		1900 2228 31	
	1089 9536 38		1900 2228 32	
	1089 9536 38		1900 2228 33	
	1089 9536 38		1900 2228 34	
	1089 9536 38		1900 2228 35	
F35-37 support		• 1	Support	
	1625 7028 00		1900 2228 11	
	1625 7028 00		1900 2228 12	
	1625 7028 00		1900 2228 13	
	1625 7028 00		1900 2228 14	
	1625 7028 00		1900 2228 15	
	1625 7028 00		1900 2228 31	
	1625 7028 00		1900 2228 32	
	1625 7028 00		1900 2228 33	
	1625 7028 00		1900 2228 34	
	1625 7028 00		1900 2228 35	
FPF20	1089 9556 04	• 1	Air inlet	
	1089 9556 22	•• 1	Filter element	
K21		• 1	Contactator	
	1089 9415 44		1900 2228 01	
	1089 9415 44		1900 2228 02	
	1089 9415 44		1900 2228 03	
	1089 9415 45		1900 2228 04	
	1089 9415 45		1900 2228 05	
	1089 9415 61		1900 2228 11	
	1089 9415 61		1900 2228 12	
	1089 9415 61		1900 2228 13	
	1089 9415 63		1900 2228 14	
	1089 9415 63		1900 2228 15	
	1089 9415 44		1900 2228 21	
	1089 9415 44		1900 2228 22	
	1089 9415 44		1900 2228 23	
	1089 9415 44		1900 2228 24	

12

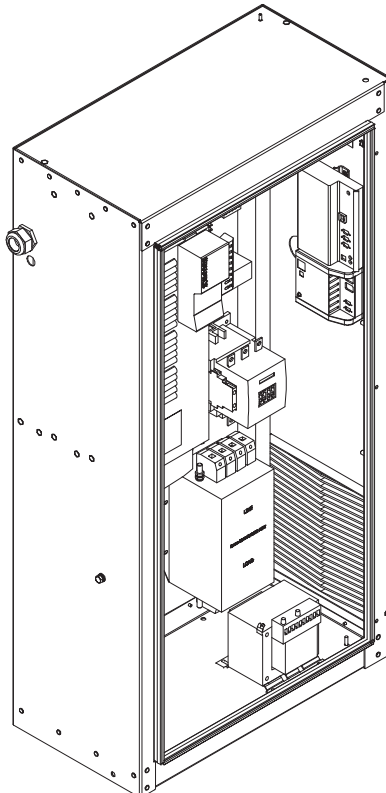
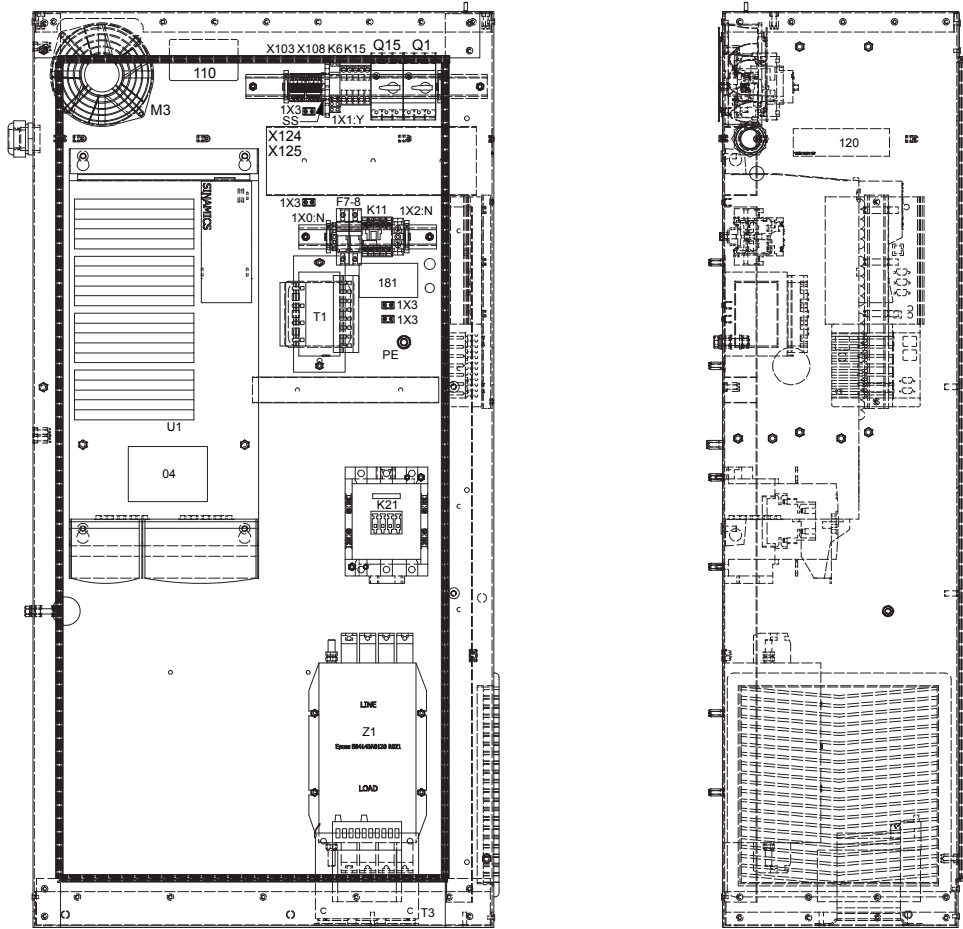

Cubicle - IEC/UL-cUL

12

Ref.	Part number	Qty	Name	Remarks
	1089 9415 44		1900 2228 25	
	1089 9415 44		1900 2228 31	
	1089 9415 44		1900 2228 32	
	1089 9415 44		1900 2228 33	
	1089 9415 44		1900 2228 34	
	1089 9415 44		1900 2228 35	
	1089 9415 44		1900 2228 41	
	1089 9415 44		1900 2228 42	
	1089 9415 44		1900 2228 43	
	1089 9415 45		1900 2228 44	
	1089 9415 45		1900 2228 45	
	1089 9415 44		1900 2228 51	
	1089 9415 44		1900 2228 52	
	1089 9415 44		1900 2228 53	
	1089 9415 44		1900 2228 54	
	1089 9415 44		1900 2228 55	
1X0:L123 on K21				
	1089 9362 02	• 6	Terminal cover	1)
1X0:L123 on K21				
	1089 9362 04	• 2	Terminal cover	2)
K21	0694 5900 08	• 3	Ring faston	3)
K21	1622 3042 00	• 6	Connection element	3)
K6	1089 9418 01	• 1	Contacteur	
L1		• 1	Choke	
	1089 9611 65		1900 2228 01	
	1089 9611 65		1900 2228 02	
	1089 9611 66		1900 2228 03	
	1089 9611 66		1900 2228 04	
	1089 9611 66		1900 2228 05	
	1089 9611 33		1900 2228 11	
	1089 9611 34		1900 2228 12	
	1089 9611 34		1900 2228 13	
	1089 9611 34		1900 2228 14	
	1089 9611 34		1900 2228 15	
	1089 9611 33		1900 2228 21	
	1089 9611 33		1900 2228 22	
	1089 9611 34		1900 2228 23	
	1089 9611 34		1900 2228 24	
	1089 9611 34		1900 2228 25	
	1089 9611 33		1900 2228 31	
	1089 9611 33		1900 2228 32	
	1089 9611 34		1900 2228 33	
	1089 9611 34		1900 2228 34	
	1089 9611 34		1900 2228 35	
	1089 9611 65		1900 2228 41	
	1089 9611 65		1900 2228 42	
	1089 9611 66		1900 2228 43	
	1089 9611 66		1900 2228 44	
	1089 9611 66		1900 2228 45	
	1089 9611 33		1900 2228 51	
	1089 9611 33		1900 2228 52	
	1089 9611 34		1900 2228 53	
	1089 9611 34		1900 2228 54	
	1089 9611 34		1900 2228 55	

12

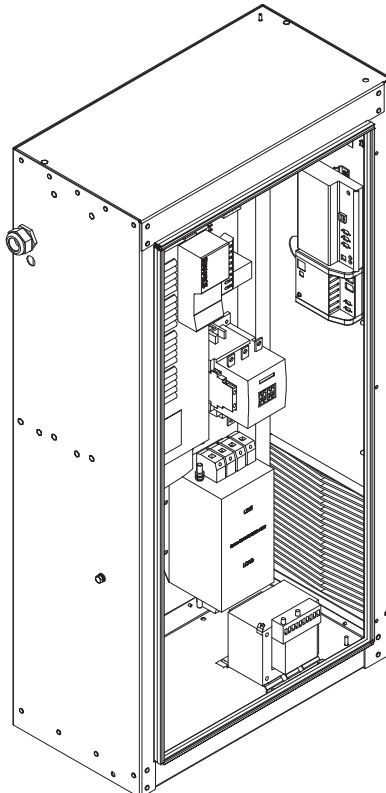
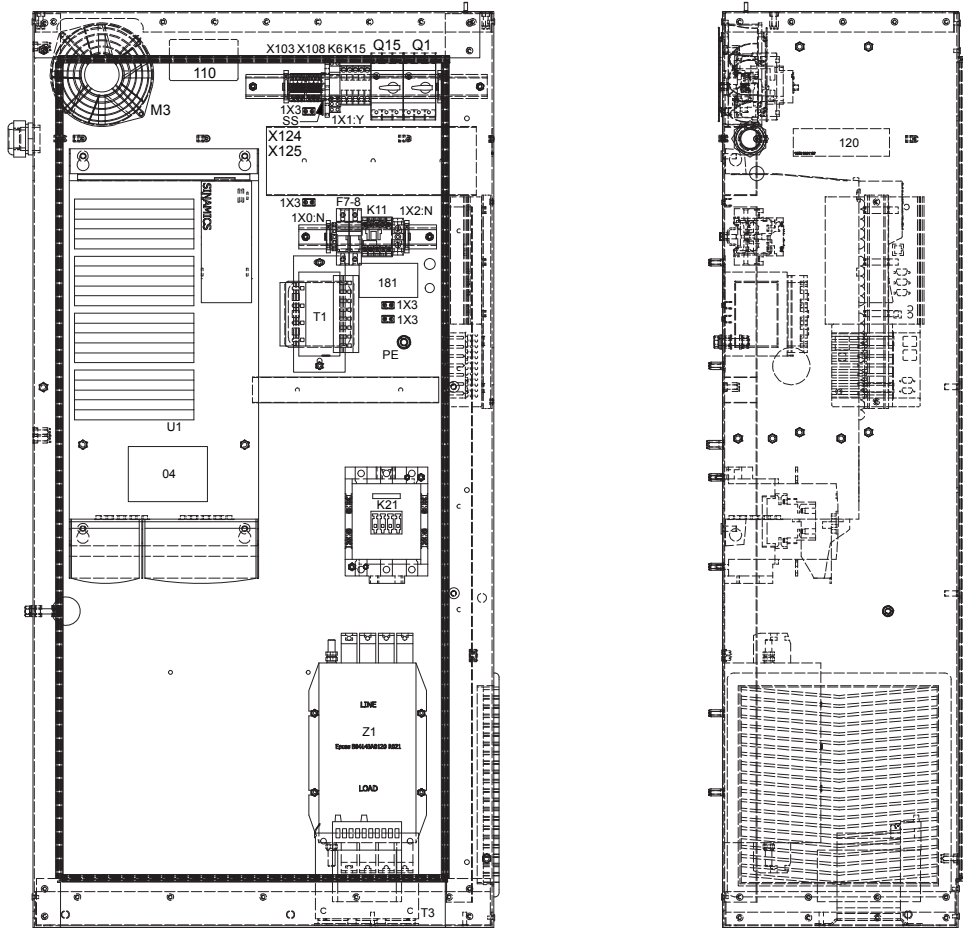

Cubicle - IEC/UL-cUL

12

Ref.	Part number	Qty	Name	Remarks
M3	1089 9556 36 •	2	Grid	
M3 (mounted inside cubicle)				
	1089 9556 39 •	1	Fan	
Q1 (0.7A)	•	1	Circuit breaker	
	1089 9416 59		1900 2228 21	
	1089 9416 59		1900 2228 22	
	1089 9416 59		1900 2228 23	
	1089 9416 59		1900 2228 24	
	1089 9416 59		1900 2228 25	
	1089 9416 59		1900 2228 31	
	1089 9416 59		1900 2228 32	
	1089 9416 59		1900 2228 33	
	1089 9416 59		1900 2228 34	
	1089 9416 59		1900 2228 35	
	1089 9416 59		1900 2228 51	
	1089 9416 59		1900 2228 52	
	1089 9416 59		1900 2228 53	
	1089 9416 59		1900 2228 54	
	1089 9416 59		1900 2228 55	
Q1 (0.9A)	•	1	Circuit breaker	
	1089 9416 59		1900 2228 01	
	1089 9416 59		1900 2228 02	
	1089 9416 59		1900 2228 03	
	1089 9416 59		1900 2228 04	
	1089 9416 59		1900 2228 05	
	1089 9416 59		1900 2228 41	
	1089 9416 59		1900 2228 42	
	1089 9416 59		1900 2228 43	
	1089 9416 59		1900 2228 44	
	1089 9416 59		1900 2228 45	
Q1 (1.8A)	•	1	Circuit breaker	
	1089 9416 63		1900 2228 11	
	1089 9416 63		1900 2228 12	
	1089 9416 63		1900 2228 13	
	1089 9416 63		1900 2228 14	
	1089 9416 63		1900 2228 15	
Q1	1089 9416 75 •	1	Connection block	
S3	1089 0362 51 •	1	Emergency stop button	
S3	1089 9337 13 •	1	Contact block	
S3	1089 9337 15 •	1	Contact block	
T1	1089 9436 44 •	1	Transformer	
T2	•	1	Spare transformer	
	1089 9426 11		1900 2228 11	
	1089 9426 11		1900 2228 12	
	1089 9426 11		1900 2228 13	
	1089 9426 10		1900 2228 14	
	1089 9426 10		1900 2228 15	
	1089 9425 31		1900 2228 21	
	1089 9425 31		1900 2228 22	
	1089 9425 31		1900 2228 23	
	1089 9425 31		1900 2228 24	
	1089 9425 31		1900 2228 25	
	1089 9426 09		1900 2228 31	

12

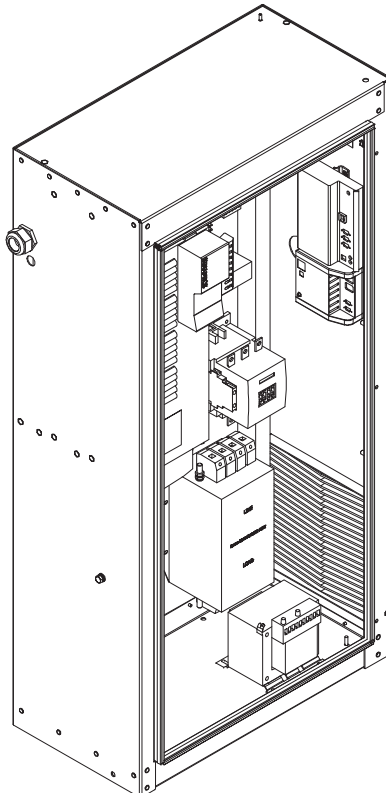
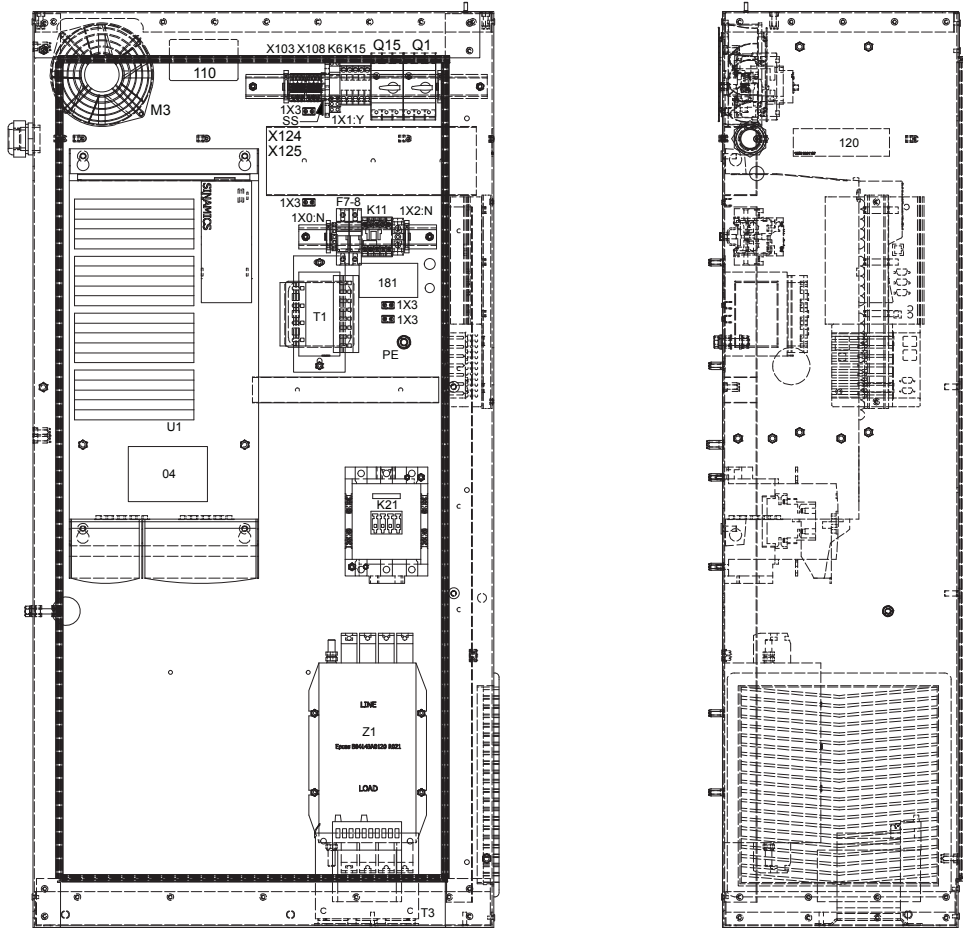

Cubicle - IEC/UL-cUL

12

Ref.	Part number	Qty	Name	Remarks
	1089 9426 09		1900 2228 32	
	1089 9426 09		1900 2228 33	
	1089 9426 09		1900 2228 34	
	1089 9426 09		1900 2228 35	
	1089 9425 31		1900 2228 51	
	1089 9425 31		1900 2228 52	
	1089 9425 31		1900 2228 53	
	1089 9425 31		1900 2228 54	
	1089 9425 31		1900 2228 55	
T2 support		• 1	Support	
	1625 7010 00		1900 2228 11	
	1625 7010 00		1900 2228 12	
	1625 7010 00		1900 2228 13	
	1625 7010 00		1900 2228 14	
	1625 7010 00		1900 2228 15	
	1625 7009 00		1900 2228 21	
	1625 7009 00		1900 2228 22	
	1625 7009 00		1900 2228 23	
	1625 7009 00		1900 2228 24	
	1625 7009 00		1900 2228 25	
	1625 7009 00		1900 2228 31	
	1625 7009 00		1900 2228 32	
	1625 7009 00		1900 2228 33	
	1625 7009 00		1900 2228 34	
	1625 7009 00		1900 2228 35	
	1625 7009 00		1900 2228 51	
	1625 7009 00		1900 2228 52	
	1625 7009 00		1900 2228 53	
	1625 7009 00		1900 2228 54	
	1625 7009 00		1900 2228 55	
T3	1089 9437 52	• 1	Autotransformer	
Terminal switch				
	1089 0506 52	• 1	Terminal switch	
U1		• 1	Power module	
	1089 9611 52		1900 2228 01	
	1089 9611 52		1900 2228 02	
	1089 9611 53		1900 2228 03	
	1089 9611 54		1900 2228 04	
	1089 9611 54		1900 2228 05	
	1089 9611 52		1900 2228 11	
	1089 9611 53		1900 2228 12	
	1089 9611 54		1900 2228 13	
	1089 9611 54		1900 2228 14	
	1089 9611 54		1900 2228 15	
	1089 9611 52		1900 2228 21	
	1089 9611 52		1900 2228 22	
	1089 9611 53		1900 2228 23	
	1089 9611 54		1900 2228 24	
	1089 9611 54		1900 2228 25	
	1089 9611 52		1900 2228 31	
	1089 9611 52		1900 2228 32	
	1089 9611 53		1900 2228 33	
	1089 9611 54		1900 2228 34	
	1089 9611 54		1900 2228 35	

12

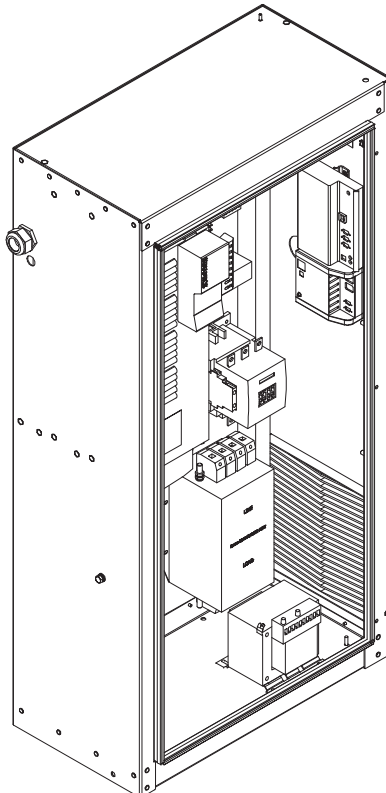
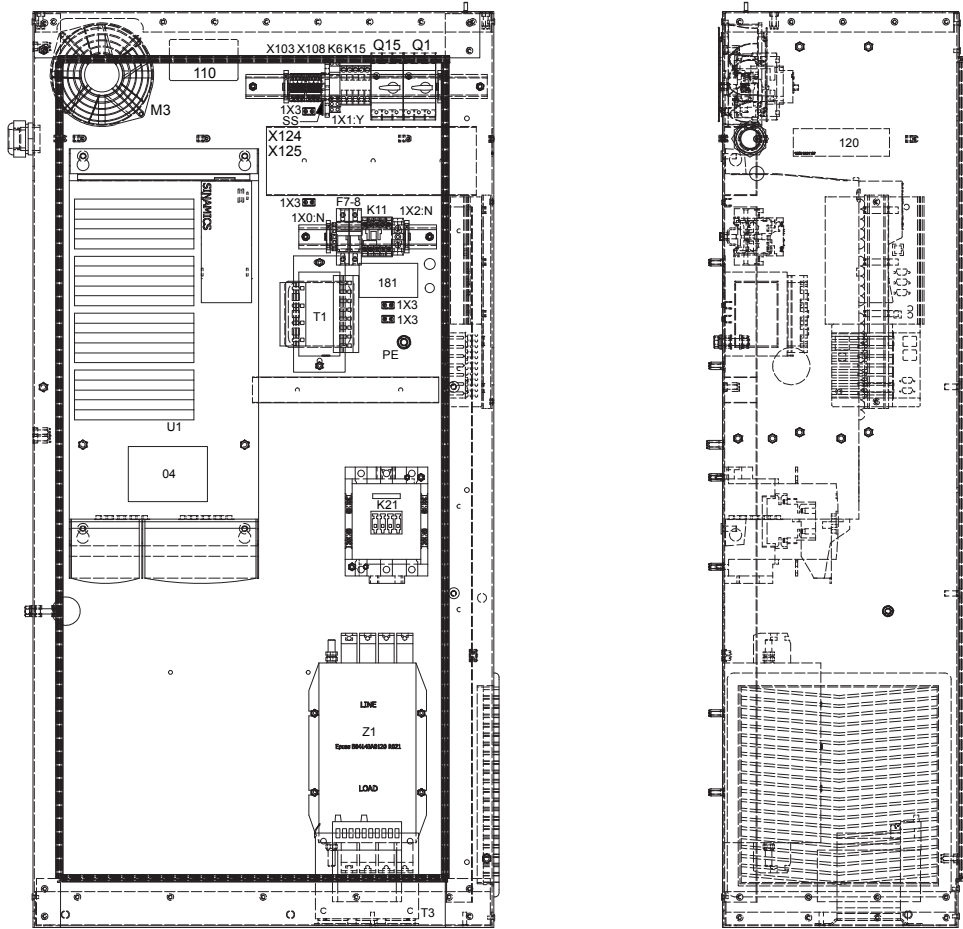

Cubicle - IEC/UL-cUL

12

Ref.	Part number	Qty	Name	Remarks
	1089 9611 25		1900 2228 41	
	1089 9611 25		1900 2228 42	
	1089 9611 26		1900 2228 43	
	1089 9611 55		1900 2228 44	
	1089 9611 55		1900 2228 45	
	1089 9611 25		1900 2228 51	
	1089 9611 25		1900 2228 52	
	1089 9611 26		1900 2228 53	
	1089 9611 55		1900 2228 54	
	1089 9611 55		1900 2228 55	
U1	1089 9611 67	• 1	Control unit	
U1	1089 9611 68	• 1	Control panel	
U1		• 1	Parameterset	
	1900 5306 70		1900 2228 01	
	1900 5306 71		1900 2228 02	
	1900 5306 72		1900 2228 03	
	1900 5306 73		1900 2228 04	
	1900 5306 74		1900 2228 05	
	1900 5306 70		1900 2228 11	
	1900 5306 90		1900 2228 12	
	1900 5306 91		1900 2228 13	
	1900 5306 73		1900 2228 14	
	1900 5306 74		1900 2228 15	
	1900 5306 75		1900 2228 21	
	1900 5306 76		1900 2228 22	
	1900 5306 77		1900 2228 23	
	1900 5306 78		1900 2228 24	
	1900 5306 79		1900 2228 25	
	1900 5306 75		1900 2228 31	
	1900 5306 76		1900 2228 32	
	1900 5306 77		1900 2228 33	
	1900 5306 78		1900 2228 34	
	1900 5306 79		1900 2228 35	
	1900 5306 70		1900 2228 41	
	1900 5306 71		1900 2228 42	
	1900 5306 72		1900 2228 43	
	1900 5306 73		1900 2228 44	
	1900 5306 74		1900 2228 45	
	1900 5306 75		1900 2228 51	
	1900 5306 76		1900 2228 52	
	1900 5306 77		1900 2228 53	
	1900 5306 78		1900 2228 54	
	1900 5306 79		1900 2228 55	
Z1		• 1	EMC-filter	
	1089 9339 52		1900 2228 41	
	1089 9339 52		1900 2228 42	
	1089 9339 52		1900 2228 43	
	1089 9339 52		1900 2228 44	
	1089 9339 52		1900 2228 45	
	1089 9339 52		1900 2228 51	
	1089 9339 52		1900 2228 52	
	1089 9339 52		1900 2228 53	
	1089 9339 52		1900 2228 54	
	1089 9339 52		1900 2228 55	

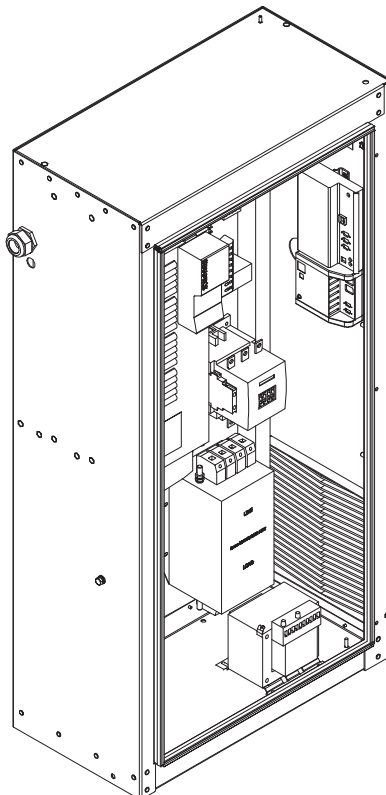
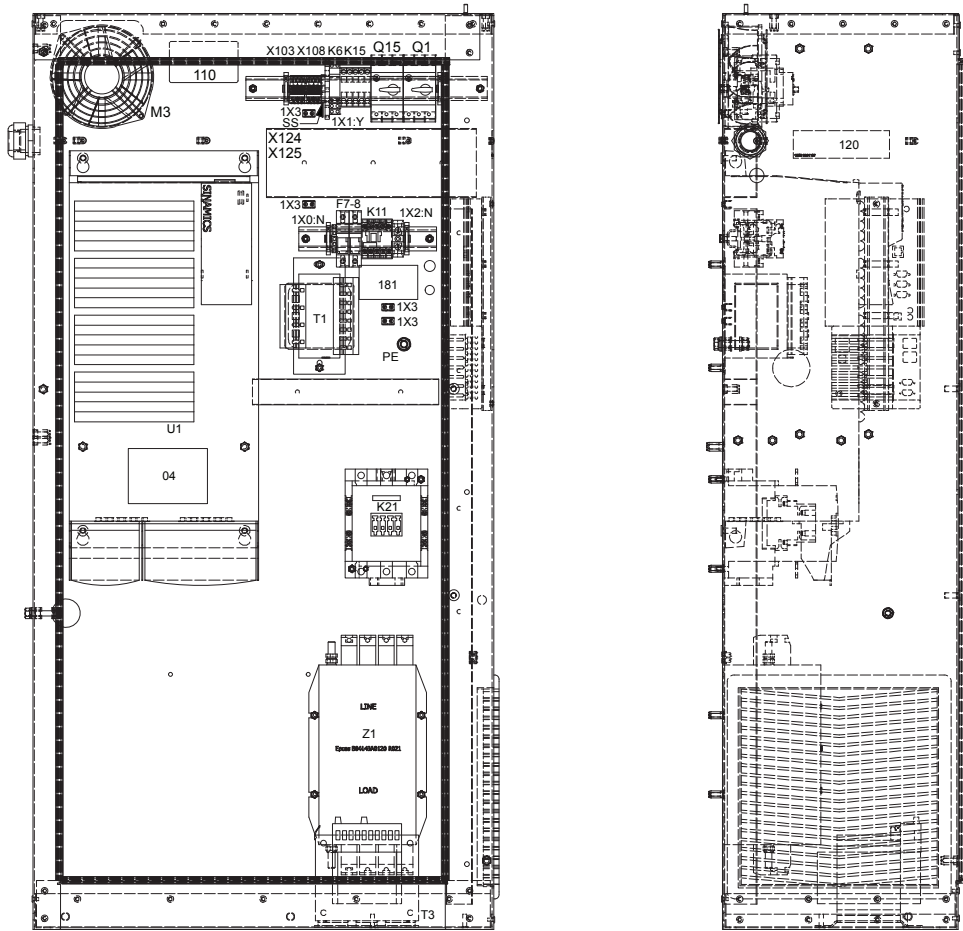

Cubicle - IEC/UL-cUL

12

Ref.	Part number	Qty	Name	Remarks
1X5-X105				
	1088 0037 30 •	2	Connector	
2X22	1089 0691 01 •	1	Connector	
2X28	1088 0037 80 •	1	Connector	
2X30	1088 0031 32 •	1	Connector	
2X31	1088 0031 26 •	1	Connector	
X103	1088 0031 87 •	1	Connector	
X103	1088 0037 07 •	1	Connector	
X103-X108-X108A-X117				
	1088 0031 18 •	8	Adaptor	
X104	1088 0037 31 •	1	Connector	
X105 to M3				
	1088 0037 62 •	1	Connector combi	
X108, X108A				
	1088 0031 83 •	2	Connector	
X108, X108A				
	1088 0037 03 •	2	Connector	
X109	1088 0037 32 •	1	Connector	
X114	1088 0015 16 •	5	Connector Pin	
X114	1088 0015 26 •	1	Connector	
X117	1088 0031 86 •	1	Connector	
X117	1088 0037 06 •	1	Connector	
X123	1088 0037 62 •	1	Connector combi	
X124-X125				
	1088 0031 37 •	2	Connector	
X132	1088 0031 43 •	1	Connector	
-	1089 9345 02 •	2	HF-screen	
-	•	1	Data label	
-	•	1	Data label	4)
-	1613 3431 00 •	1	Label	4)
-	1079 9901 61 •	1	Label	
-	1079 9925 69 •	1	Label	
-	•	1	Label	
	1079 9928 72		1900 2228 11	
	1079 9928 72		1900 2228 12	
	1079 9928 72		1900 2228 13	
	1079 9928 73		1900 2228 14	
	1079 9928 73		1900 2228 15	
	1079 9928 72		1900 2228 31	
	1079 9928 72		1900 2228 32	
	1079 9928 72		1900 2228 33	
	1079 9928 72		1900 2228 34	
	1079 9928 72		1900 2228 35	
-	1089 0577 58 •	4	End retainer	
-	•	AR	Mounting rail	
	0090 1400 02		35x15	
for WH	0697 9809 24 •	1	Nut	M40x1.5
for Temperature sensor	0697 9809 30 •	1	Nut	M12x1.5
for Temperature sensor	0698 5140 70 •	1	Cable gland	M12x1.5

12

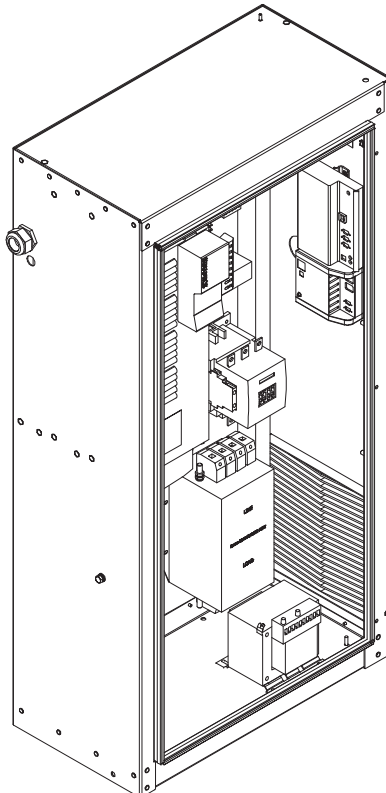
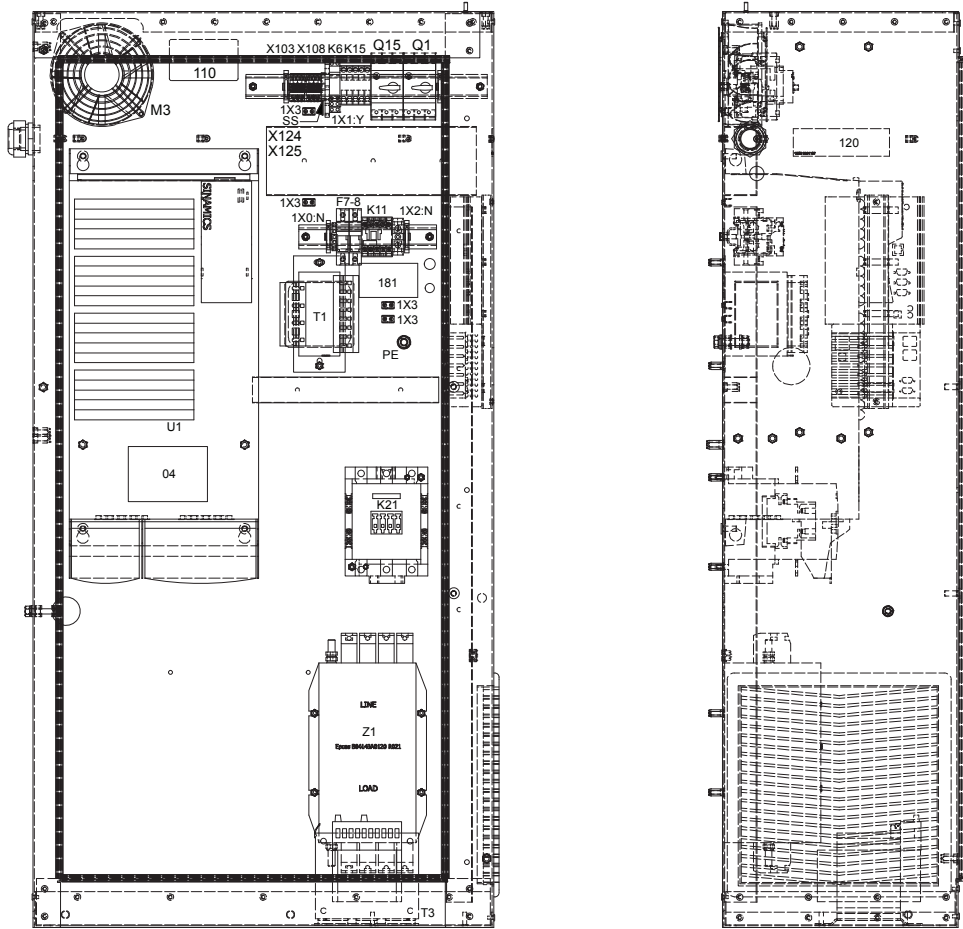

Cubicle - IEC/UL-cUL

12

Ref.	Part number	Qty	Name	Remarks
		• 1	Metal sheet assembly	
	1622 6934 81		1900 2228 01	
	1622 6934 81		1900 2228 02	
	1622 6934 81		1900 2228 03	
	1622 6934 81		1900 2228 04	
	1622 6934 81		1900 2228 05	
	1622 6934 80		1900 2228 11	
	1622 6934 80		1900 2228 12	
	1622 6934 80		1900 2228 13	
	1622 6934 80		1900 2228 14	
	1622 6934 80		1900 2228 15	
	1622 6934 80		1900 2228 21	
	1622 6934 80		1900 2228 22	
	1622 6934 80		1900 2228 23	
	1622 6934 80		1900 2228 24	
	1622 6934 80		1900 2228 25	
	1622 6934 80		1900 2228 31	
	1622 6934 80		1900 2228 32	
	1622 6934 80		1900 2228 33	
	1622 6934 80		1900 2228 34	
	1622 6934 80		1900 2228 35	
	1622 6934 81		1900 2228 41	
	1622 6934 81		1900 2228 42	
	1622 6934 81		1900 2228 43	
	1622 6934 81		1900 2228 44	
	1622 6934 81		1900 2228 45	
	1622 6934 80		1900 2228 51	
	1622 6934 80		1900 2228 52	
	1622 6934 80		1900 2228 53	
	1622 6934 80		1900 2228 54	
	1622 6934 80		1900 2228 55	
		•• 1	Cubicle	
	1622 6934 00		1622 6934 80	
	1622 6934 10		1622 6934 81	
	1202 6584 00	•• AR	Seal	
	0147 1247 03	•• 4	Bolt	
	0266 2108 00	•• 4	Nut	
		1	Dryer rail - Full Feature	
	1900 2602 01		IEC	
	1900 2602 51		UL-cUL	
-	9820 5207 81	• 1	Assembly drawing	
F7-F8		• 2	Fuse holder	
	1089 0612 01		IEC	
	1089 0612 02		UL-cUL	
F7-F8		• 2	Fuse	
	1089 0612 28		IEC	
	1089 9168 62		UL-cUL	
faston cover				
	0694 5285 12	• 2	Isolator cap female fast	
faston cover				
	1088 0003 24	• 2	Cable lug faston	
K11	1089 9415 16	• 1	Contactora	
on K11	0694 5900 10	• 2	Fork faston	

12

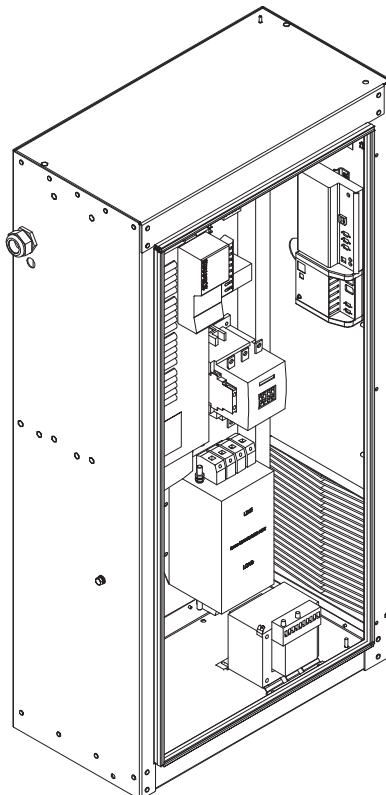
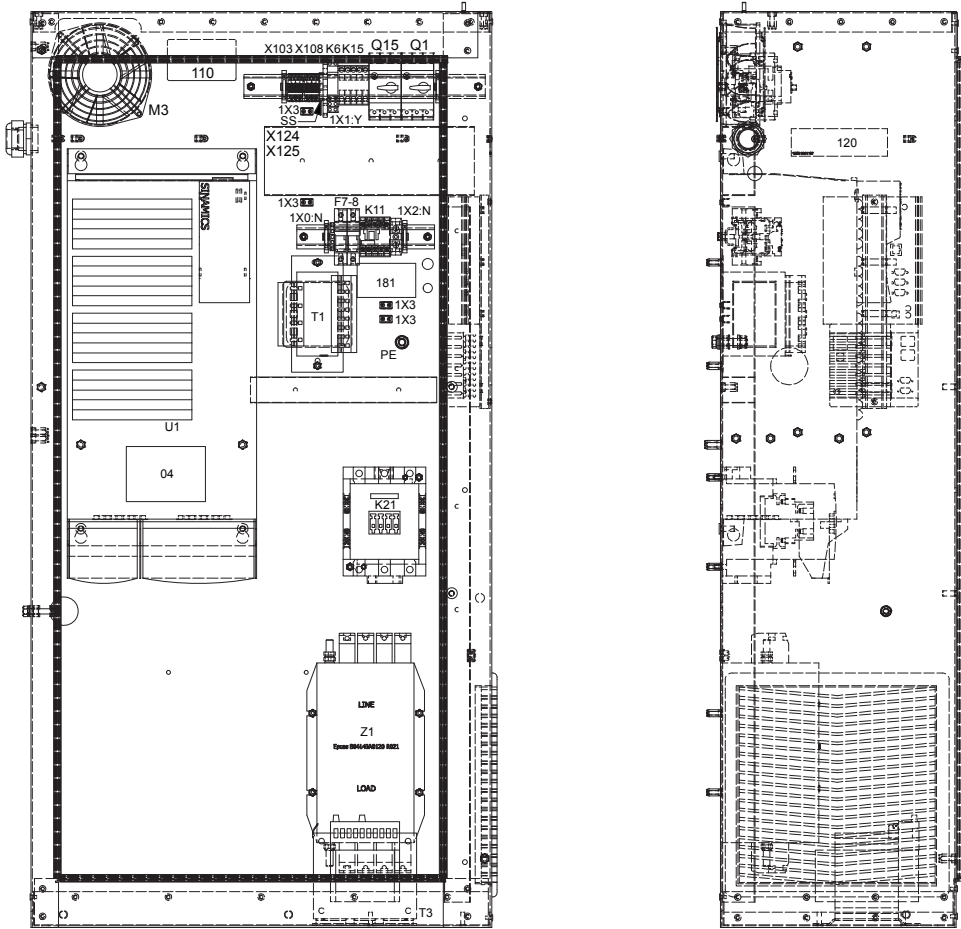

Cubicle - IEC/UL-cUL

12

Ref.	Part number	Qty	Name	Remarks
L1-L2	0694 5285 25	• 2	Cable lug	
1X0:N		• 1	Terminal	
	1089 0506 06		IEC	
1X2:N		• 1	Terminal	
	1089 0506 60		IEC	
	1089 0506 06		UL-cUL	
X104	1088 0037 63	• 1	Connector combi	
X114	1088 0015 05	• 1	Connector	
X114	1088 0015 36	• 5	Connector socket	
-		• 1	Label	
	1079 9924 71		UL-cUL	
-	1089 0577 58	• 2	End retainer	
-		• AR	Mounting rail	
	9139 5000 16		35x7.5	
1-3)	For			
	1) Contactor (K21) 1089 9415 61, 1089 9415 63			
	2) Contactor (K21) 1089 9415 44, 1089 9415 45			
	3) On motorside of Contactor (K23) 1089 9415 61, 1089 9415 63			
4)	Delivered loose in plastic bag			

13

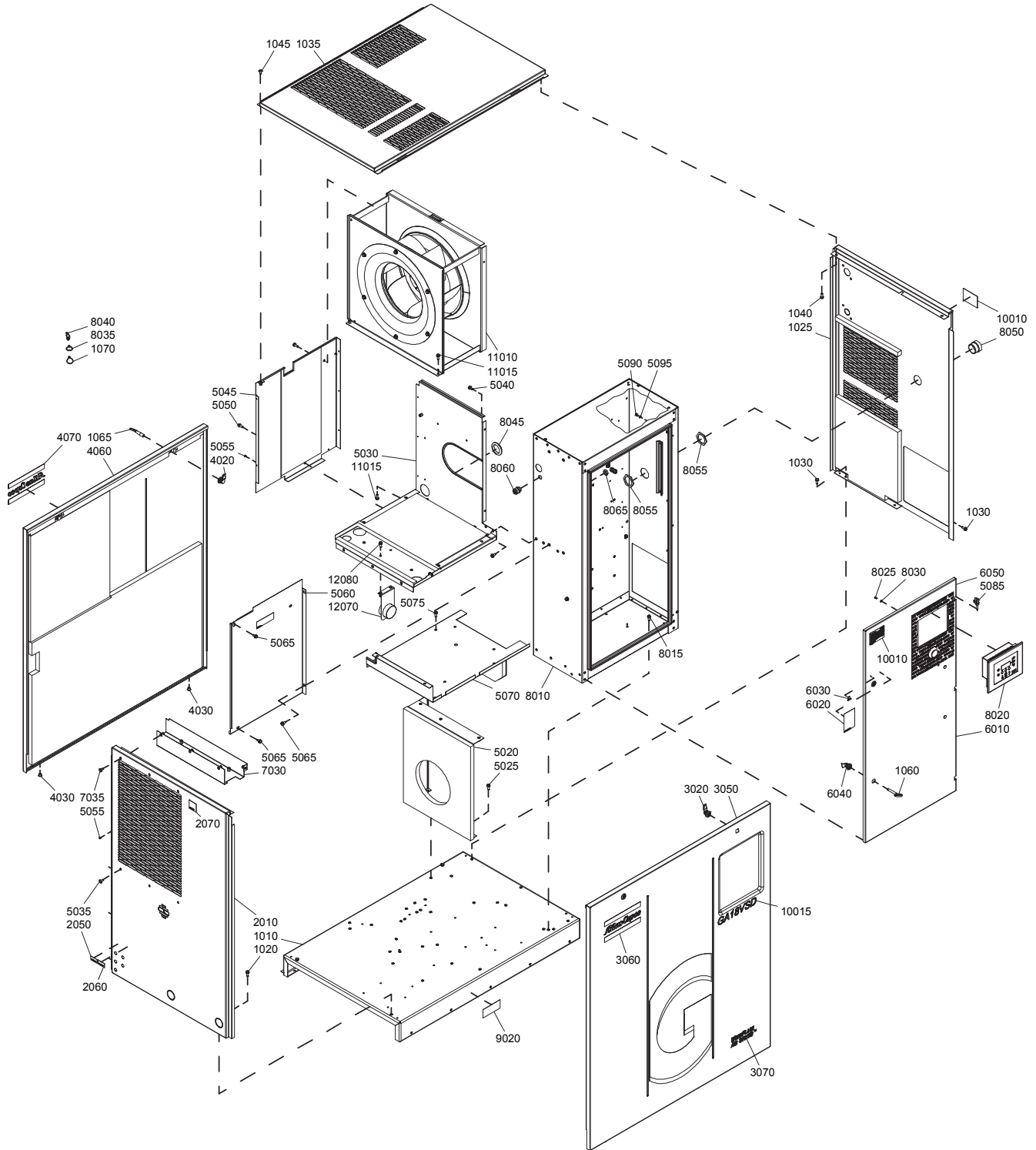

Bodywork

13

Ref.	Part number	Qty	Name	Remarks
1010	1622 6933 80	1	Frame	
1020	0147 1963 08	2	Hexagon bolt	
1025		1	Panel	3)
	1625 7026 80		GA 15 VSD	
	1622 6985 80		GA 18 VSD	
	1622 6985 80		GA 22 VSD	
	1622 6985 80		GA 26 VSD	
	1622 6985 80		GA 30 VSD	
1030	0147 1963 08	3	Hexagon bolt	
1035	1622 6917 80	1	Panel	3)
1040	0147 1963 08	3	Hexagon bolt	
1045	0215 0006 14	1	Screw	
1060	1089 9154 02	1	Key	
1065	1089 9068 01	1	Key	
1070	1088 1301 02	1	Cable strip	
		1	Panel	3)4)
	1622 7904 81		GA 15 VSD	
	1622 7870 80		GA 18 VSD	
	1622 7870 80		GA 22 VSD	
	1622 6915 80		GA 26 VSD	
	1622 6915 80		GA 30 VSD	
2010		• 1	Panel	
2050	1079 9915 89	• 1	Decal	
2060	1079 9915 98	• 1	Decal	
2070	1079 9902 55	• 1	Decal	
	1622 6905 80	1	Panel	2)3)
3020	1513 0431 00	• 2	Lock	
3050	1622 6905 00	• 1	Panel	
3060	0690 1125 01	• 1	House mark	
3070	1613 9846 00	• 1	Decal	
	1622 6907 80	1	Panel	2)3)
4020	1513 0431 00	• 2	Door lock	
4030	0686 9300 05	• 2	Plug	
4060		• 1	Panel	
4070	0690 1125 01	• 1	House mark	
5020	1622 7826 80	1	Baffle	3)
	1619 2758 00	• AR	Seal	
5025	0147 1963 08	3	Hexagon bolt	
5030		1	Support	3)
	1622 6922 82		GA 15 VSD	
	1622 6922 82		GA 18 VSD	
	1622 6922 82		GA 22 VSD	
	1622 6945 82		GA 26 VSD	
	1622 6945 82		GA 30 VSD	
	1619 3843 00	• AR	Seal	
	1619 2758 00	• AR	Seal	
5035	0215 0006 14	3	Screw	
5040	1079 1472 05	4	Bolt	
5045	1622 6940 80	1	Plate	1)
	1619 2665 00	• AR	Seal	
5050	0147 1963 08	1	Hexagon bolt	
5055	0129 3270 51	7	Rivet	

13

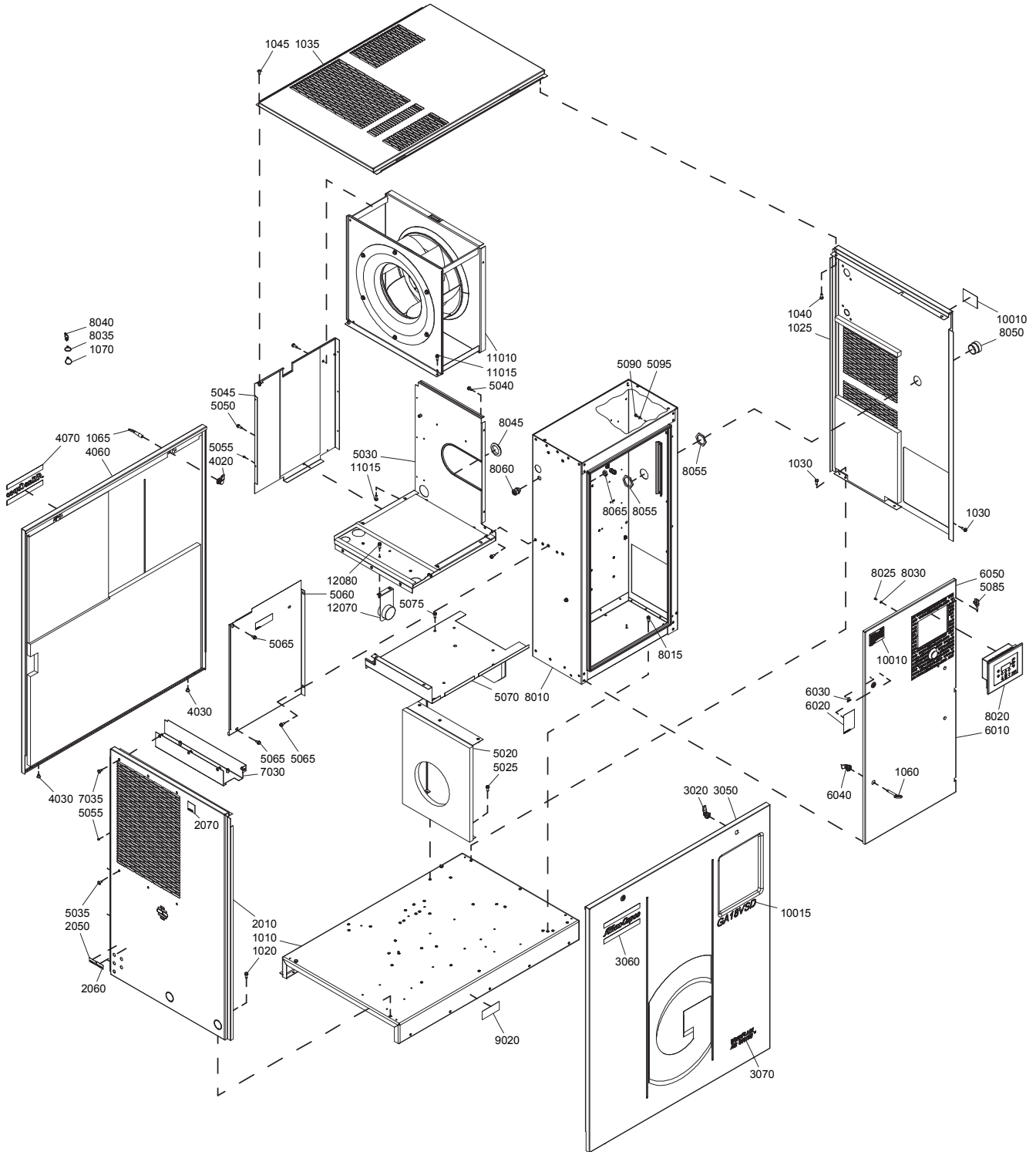

Bodywork

13

Ref.	Part number	Qty	Name	Remarks
5060		1	Baffle	1)3)
	1622 7839 80		GA 15 VSD	
	1622 7839 80		GA 18 VSD	
	1622 7839 80		GA 22 VSD	
	1622 6974 80		GA 26 VSD	
	1622 6974 80		GA 30 VSD	
	1079 9901 18	• 1	Warning label	
	1619 2758 00	• AR	Seal	
5065	1079 1472 05	4	Bolt	
5070	1622 6944 80	1	Plate	3)
	1619 2758 00	• AR	Seal	
5075	0147 1963 08	4	Hexagon bolt	
5085	1202 6400 00	3	Hinge	
5090	0147 1244 03	3	Hexagon bolt	
5095	0301 2321 00	3	Washer	
	1622 6935 80	1	Door	
6010		• 1	Door	
6020	1079 9903 48	• 1	Warning label	
6030	1088 1001 01	• 1	Warning mark	
6040	1619 7705 00	• 2	Lock	
6050	1625 7002 00	• 1	Label	
7030		1	Support	
	1622 7868 00		GA 15 VSD	
	1622 7848 00		GA 18 VSD	
	1622 7822 00		GA 22 VSD	
	1622 6959 00		GA 26 VSD	
	1622 6959 00		GA 30 VSD	
7035	0215 0006 14	3	Screw	
8010	<<< >>>	1	Cubicle	
8015	0147 1963 08	5	Hexagon bolt	
8020		1	Controller	
	1900 5200 12		Elektronikon® Mk5 Graphic	
8025	0147 1169 03	4	Hexagon bolt	
8030	0301 2315 00	4	Washer	
8035	1088 1301 02	6	Cable strip	
8040	0348 0102 11	4	Cable tie	
8045	0989 4220 10	1	Grommet	
8050	1622 7841 00	1	Adapter	
8055	0697 9809 05	2	Lock nut	
8060	0698 5140 72	1	Cable gland	
8065	0697 9809 21	1	Lock nut	
9020		1	Label	
	1079 9909 57		Roto-Inject Fluid	
	1079 9925 87		Roto-Xtend Duty Fluid	
	1079 9920 99		Foodgrade Fluid	
10010		2	Data label	
10015		1	Decal	
	1622 4631 65		GA15VSD	
	1622 4631 66		GA15VSD FF	
	1622 4631 51		GA18VSD	
	1622 4631 52		GA18VSD FF	
	1622 4631 19		GA22VSD	
	1622 4631 20		GA22VSD FF	
	1622 4631 67		GA26VSD	

13

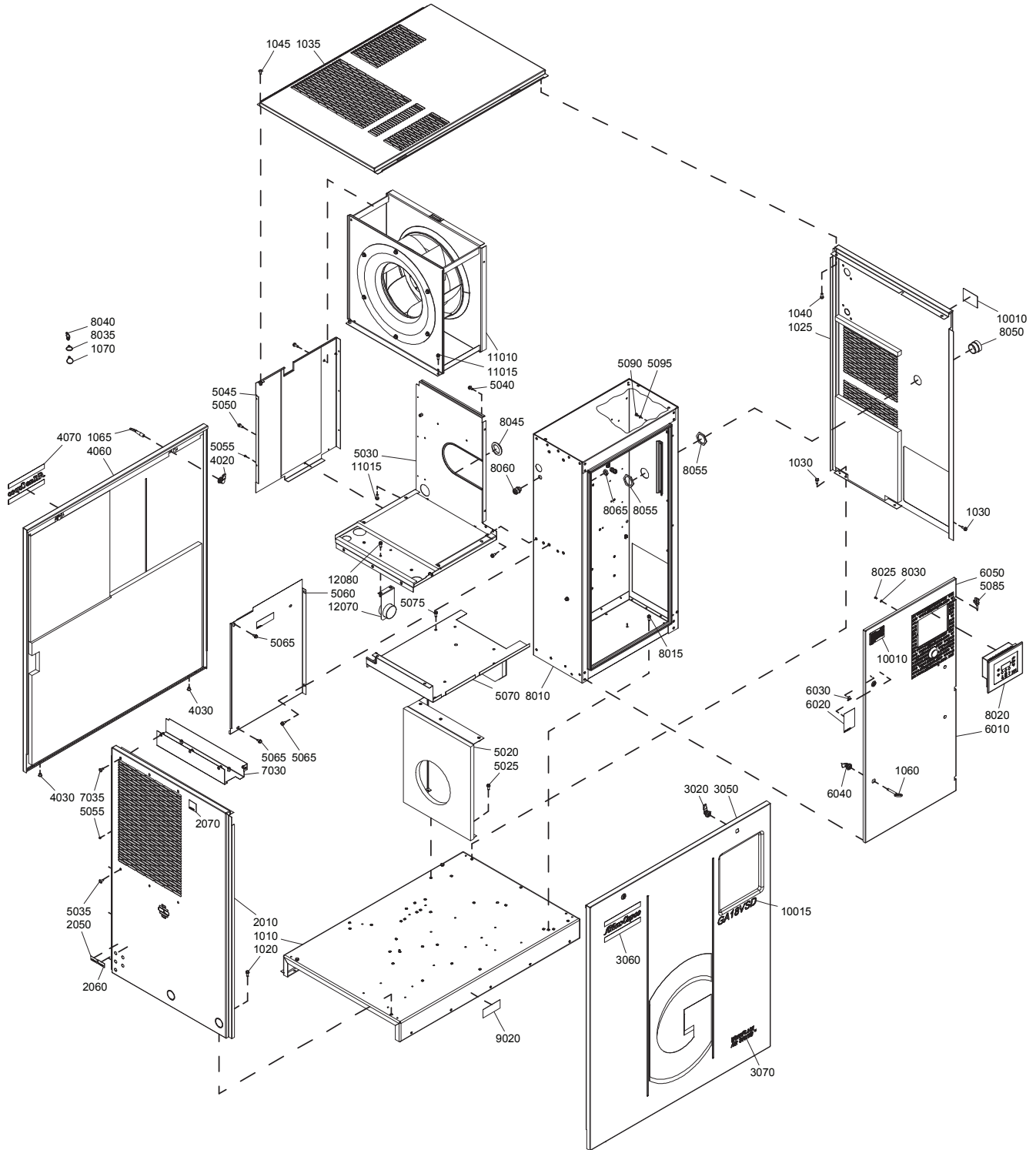

Bodywork

13

Ref.	Part number	Qty	Name	Remarks
	1622 4631 68		GA26VSD FF	
	1622 4631 21		GA30VSD	
	1622 4631 22		GA30VSD FF	
11010		1	Fan assembly	
	1622 7817 01		200V/50Hz	
	1622 7817 11		200V/60Hz	
	1622 7817 01		220V/50Hz	
	1622 7817 11		220V/60Hz	
	1622 7817 04		230V/50Hz	
	1622 7817 12		230V/60Hz	
	1622 7817 12		380V/60Hz	
	1622 7817 04		400V/50Hz	
	1622 7817 12		460V/60Hz	
	1622 7817 06		500V/50Hz	
	1622 7817 16		575V/60Hz	
	1503 0786 00	•	Rotation arrow	
	1088 1001 01	•	Warning mark	
11015	0147 1963 08	6	Hexagon bolt	
12070	1625 7097 00	1	Support	
12080	0147 1963 08	2	Bolt	

1-4)

Lined with:

- 1) Foam: 0395 6001 64 (AR) 5 x 2040 x 1650 (self-adhesive)
- 2) Foam: 0395 6001 63 (AR) 15 x 2040 x 1650 (self-adhesive)
- 3) Foam: 0395 6001 66 (AR) 25 x 2040 x 1650 (self-adhesive)
- 4) Foam: 0395 6001 69 (AR) 50 x 2040 x 1650 (self-adhesive)

14

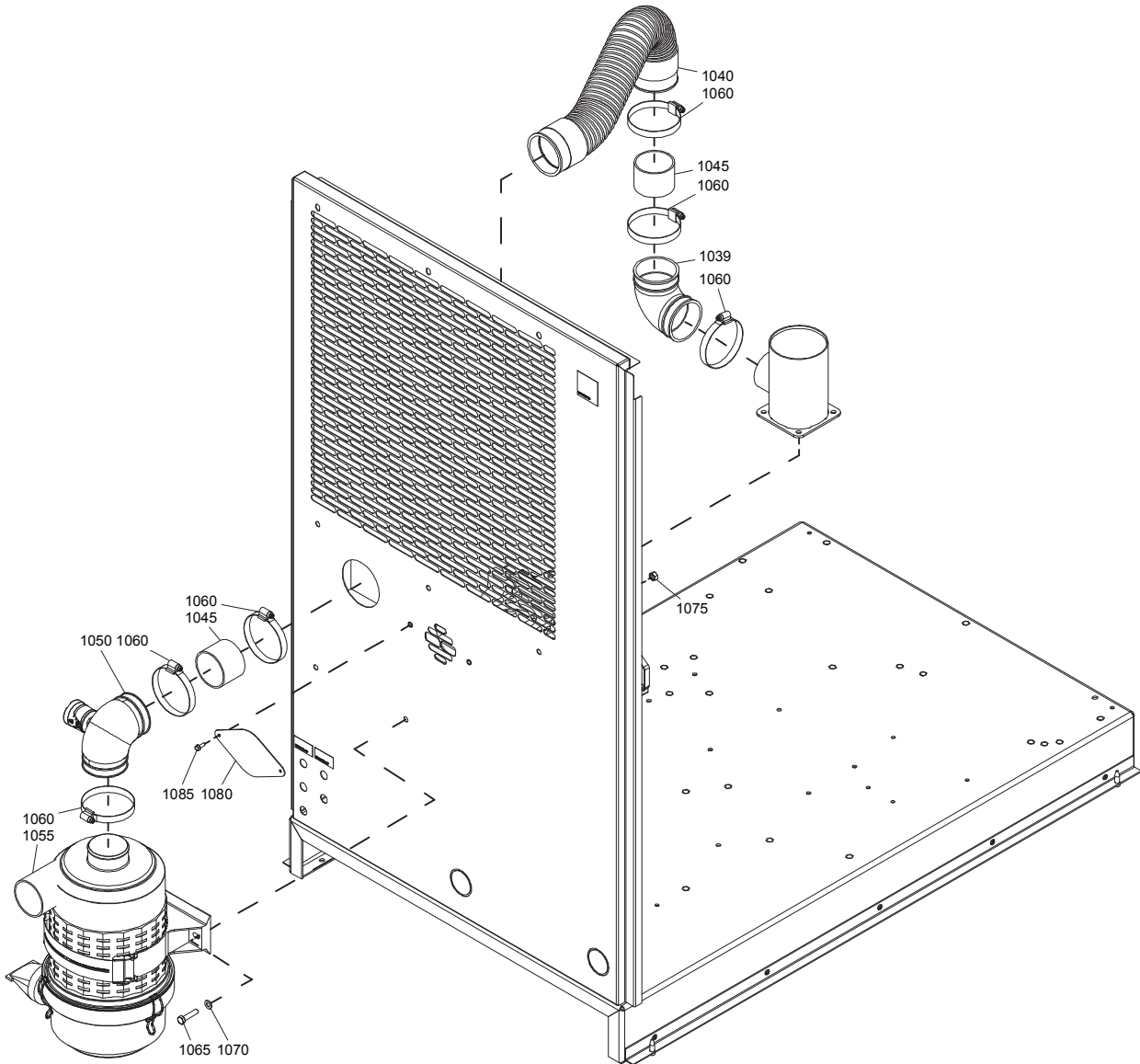

Standard option - Heavy duty filter

14

Ref.	Part number	Qty	Name	Remarks
	8092 2910 72	1	Standard option	
			Heavy duty filter	
1039	1622 4741 00 •	1	Elbow	
1040	1625 7004 80 •	1	Hose assy	
1045	1622 4780 00 •	2	Tube	
1050	1625 7033 80 •	1	Hose assembly	
		••	Bend	
	1613 7612 01 ••	1	Indicator	
1055	1625 7003 80 •	1	Filter assembly	
	1604 6227 00 ••	1	Filter	
	1615 7044 00 ••	1	Support	
1060	0347 6100 04 •	6	Hose clip	
1065	0147 1327 03 •	2	Hexagon bolt	
1070	0301 2335 00 •	2	Washer	
1075	0266 2110 00 •	2	Nut	
1080	1622 7877 80 •	1	Plate	
1085	1079 2263 02 •	2	Screw	

15

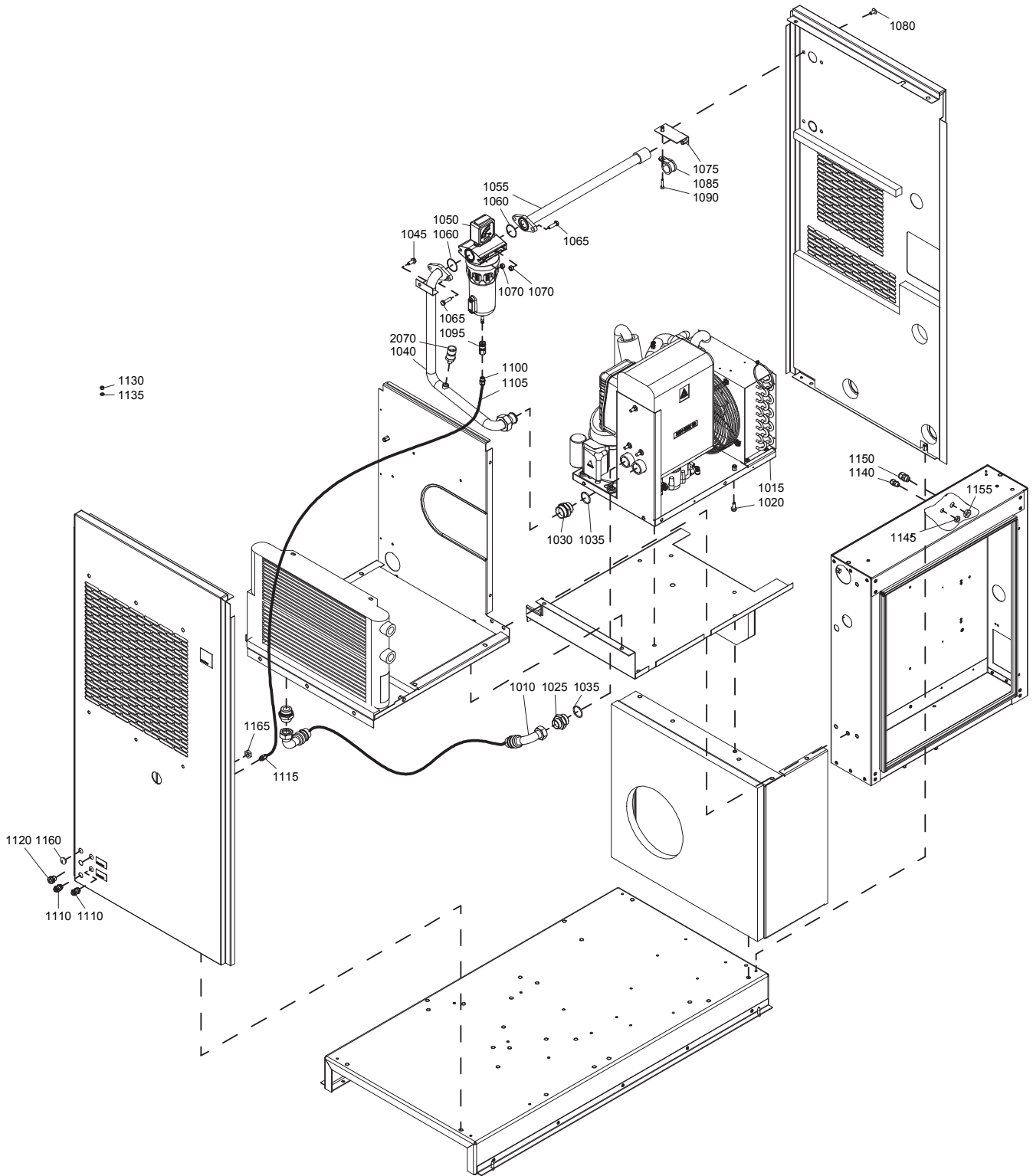

Standard option - DD filter - GA 15 VSD

15

Ref.	Part number	Qty	Name	Remarks
	8092 2911 48	1	Standard option	
			DD filter	
1010	0575 0366 29 •	1	Hose assembly	
1015	<<< >>> •	1	Air dryer	
1020	0147 1963 08 •	3	Hexagon bolt	
1025	0571 0036 31 •	1	Nipple	
1030	0571 0036 01 •	1	Nipple	
1035	0663 3130 00 •	2	O-ring	
1040	1625 7012 00 •	1	Pipe	
1045	0147 1963 08 •	1	Hexagon bolt	
1050	<<< >>> •	1	DD filter	
1055	1625 7990 00 •	1	Pipe	
1060	0663 2101 97 •	2	O-ring	
1065	0147 1326 03 •	4	Hexagon bolt	
1070	0266 2110 00 •	4	Nut	
1075	1622 7881 00 •	1	Support	
1080	0215 0006 14 •	2	Screw	
1085	0346 1002 10 •	1	Pipe clamp	
1090	0211 1965 60 •	1	Hexagon bolt	
1095	1617 7082 02 •	1	Coupling	
1100	0583 8100 69 •	1	Coupling	
1105	0070 6002 05 •	AR	Plastic tube	
1110	0583 8100 70 •	2	Coupling	
1115	0583 8100 66 •	1	Fitting	
1120	0581 0000 43 •	1	Coupling	
1140	0698 5140 70 •	1	Cable gland	
1145	0697 9809 30 •	1	Lock nut	
1150	0698 5140 71 •	1	Cable gland	
1155	0697 9809 20 •	1	Lock nut	
1160	0697 9810 25 •	1	Plug	
1165	0697 9809 20 •	1	Lock nut	
2070	1089 0575 54 •	1	Pressure transducer	

16

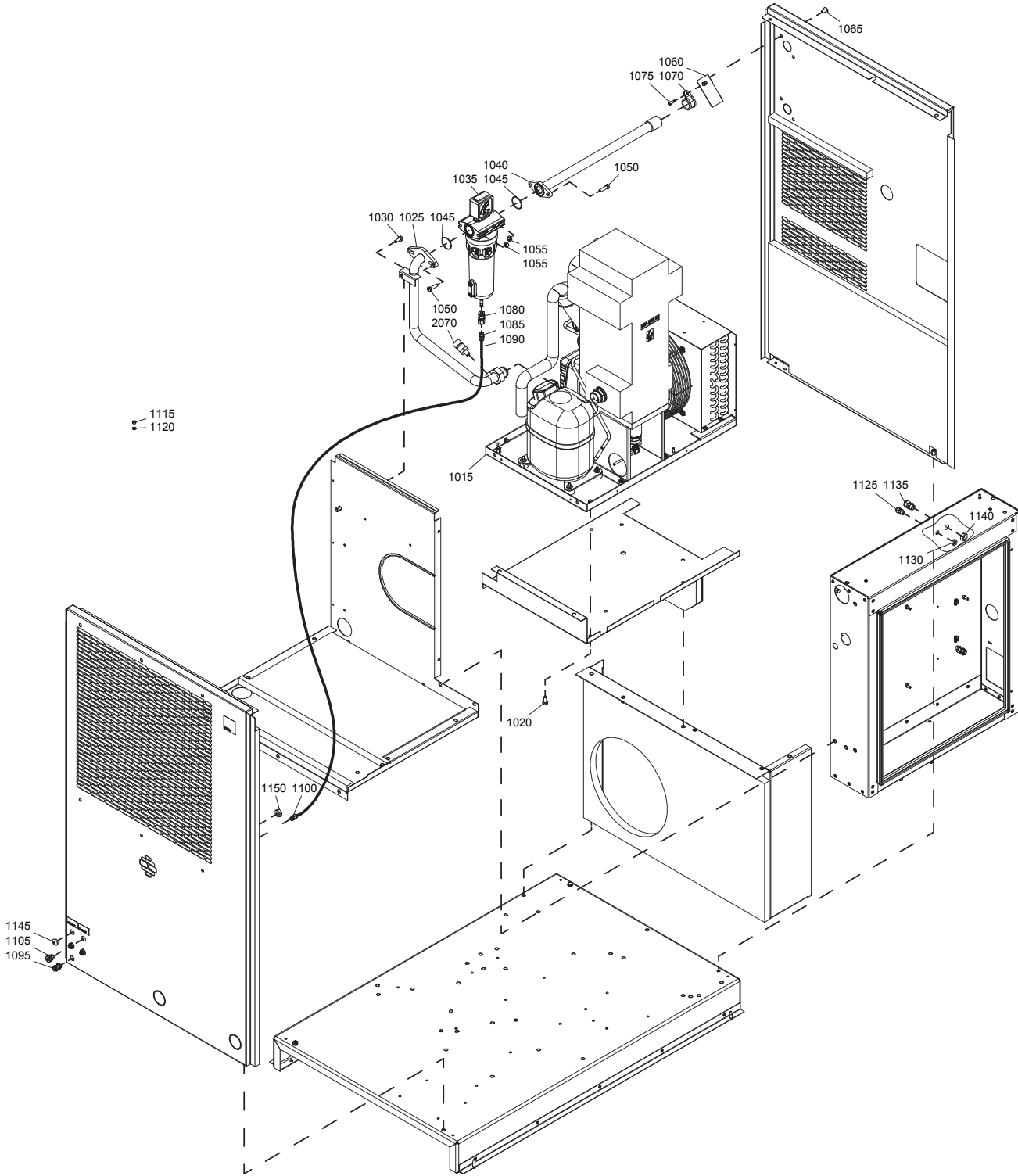

Standard option - DD filter - GA 18 VSD, GA 22 VSD, GA 26 VSD, GA 30 VSD

16

Ref.	Part number	Qty	Name	Remarks
		1	Standard option	
			DD filter	
	8092 2911 55		GA 18 VSD (ID60) no 200V/50Hz	
	8092 2911 55		GA 18 VSD (ID60) no 200V/60Hz	
	8092 2911 55		GA 18 VSD (ID71) 200V/50Hz	
	8092 2911 55		GA 18 VSD (ID71) 200V/60Hz	
	8092 2911 55		GA 22 VSD (ID71) no 200V/50Hz	
	8092 2911 55		GA 22 VSD (ID71) no 200V/60Hz	
	8092 2911 55		GA 22 VSD (ID71) 200V/50Hz	
	8092 2911 55		GA 22 VSD (ID71) 200V/60Hz	
	8092 2911 63		GA 26 VSD (ID93) no 200V/50Hz	
	8092 2911 63		GA 26 VSD (ID93) no 200V/60Hz	
	8092 2911 63		GA 26 VSD (ID93) 200V/50Hz	
	8092 2911 63		GA 26 VSD (ID93) 200V/60Hz	
	8092 2911 63		GA 30 VSD (ID93) no 200V/50Hz	
	8092 2911 63		GA 30 VSD (ID93) no 200V/60Hz	
	8092 2911 63		GA 30 VSD (ID93) 200V/50Hz	
	8092 2911 63		GA 30 VSD (ID93) 200V/60Hz	
1025	1622 7879 00	• 1	Pipe	
1030	0147 1963 08	• 1	Hexagon bolt	
1035	<<< >>>	• 1	DD filter	
1040		• 1	Pipe	
	1625 7990 00		DD 60	
	1625 7991 00		DD 120	
1045		• 2	O-ring	
	0663 2101 97		DD 60	
	0663 2104 75		DD 120	
1050	0147 1326 03	• 4	Hexagon bolt	
1055	0266 2110 00	• 4	Nut	
1060	1622 7881 00	• 1	Support	
1065	0215 0006 14	• 2	Screw	
1070	0346 1002 10	• 1	Pipe clamp	
1075	0211 1965 60	• 1	Hexagon bolt	
1080	1617 7082 02	• 1	Quick Coupling	
1085	0583 8100 69	• 1	Coupling	
1090	0070 6002 05	• AR	Plastic tube	
1095	0583 8100 70	• 2	Coupling	
1100	0583 8100 66	• 1	Fitting	
1105	0581 0000 43	• 1	Coupling	
1125	0698 5140 70	• 1	Cable gland	
1130	0697 9809 30	• 1	Lock nut	
1135	0698 5140 71	• 1	Cable gland	
1140	0697 9809 20	• 1	Lock nut	
1145	0697 9810 25	• 1	Plug	
1150	0697 9809 20	• 1	Lock nut	
2070	1089 0575 54	• 1	Pressure transducer	

17

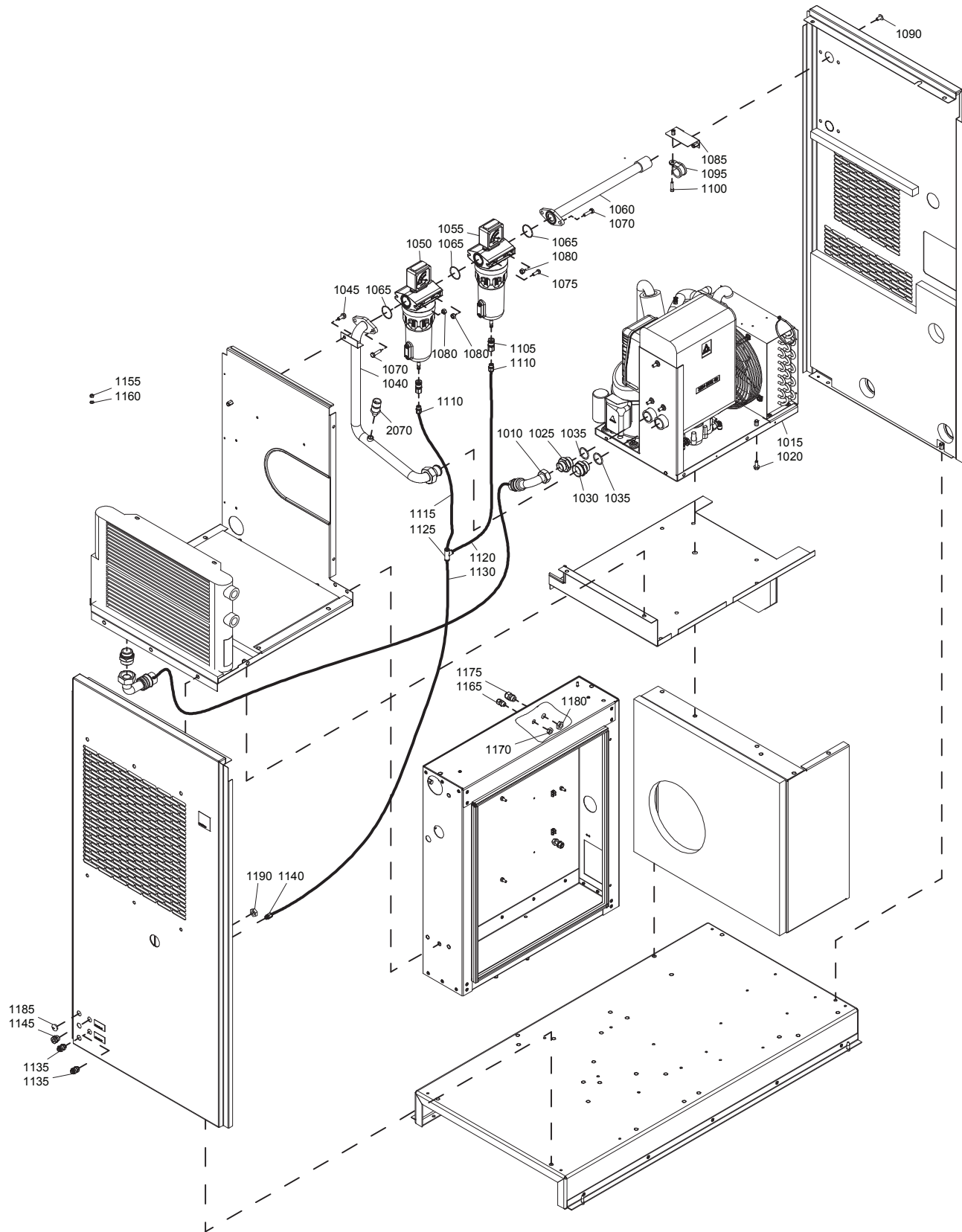

Standard option - DD/PD filter - GA 15 VSD

17

Ref.	Part number	Qty	Name	Remarks
		1	Standard option	
			DD/PD filter	
	8092 2911 14		GA 15 VSD (ID46)	
1010	0575 0366 29 •	1	Hose assembly	
1015	<<< >>> •	1	Air dryer	
1020	0147 1963 08 •	3	Hexagon bolt	
1025	0571 0036 31 •	1	Nipple	
1030	0571 0036 01 •	1	Nipple	
1035	0663 3130 00 •	2	O-ring	
1040	1625 7012 00 •	1	Pipe	
1045	0147 1963 08 •	1	Hexagon bolt	
1050	<<< >>> •	1	DD filter	
1055	<<< >>> •	1	PD filter	
1060	1625 7970 00 •	1	Pipe	
1065	0663 2101 97 •	3	O-ring	
1070	0147 1326 03 •	4	Hexagon bolt	
1075	0215 0003 73 •	2	Screw	
1080	0266 2110 00 •	6	Nut	
1085	1622 7881 00 •	1	Support	
1090	0215 0006 14 •	2	Screw	
1095	0346 1002 10 •	1	Pipe clamp	
1100	0211 1965 60 •	1	Hexagon bolt	
1105	1617 7082 02 •	2	Coupling	
1110	0583 8100 69 •	2	Coupling	
1115	0070 6002 05 •	AR	Plastic tube	
1120	0070 6002 05 •	AR	Plastic tube	
1125	0583 8140 50 •	1	Tee	
1130	0070 6002 05 •	AR	Plastic tube	
1135	0583 8100 70 •	2	Coupling	
1135	0583 8100 70 •	2	Fitting pipe	
1140	0583 8100 66 •	1	Fitting	
1145	0581 0000 43 •	1	Coupling	
1155	0266 2108 00 •	2	Nut	
1160	0301 2321 00 •	2	Washer	
1165	0698 5140 70 •	1	Cable gland	
1170	0697 9809 30 •	1	Lock nut	
1175	0698 5140 71 •	1	Cable gland	
1180	0697 9809 20 •	1	Lock nut	
1185	0697 9810 25 •	1	Plug	
1190	0697 9809 20 •	1	Lock nut	
2070	1089 0575 54 •	1	Pressure transducer	

18

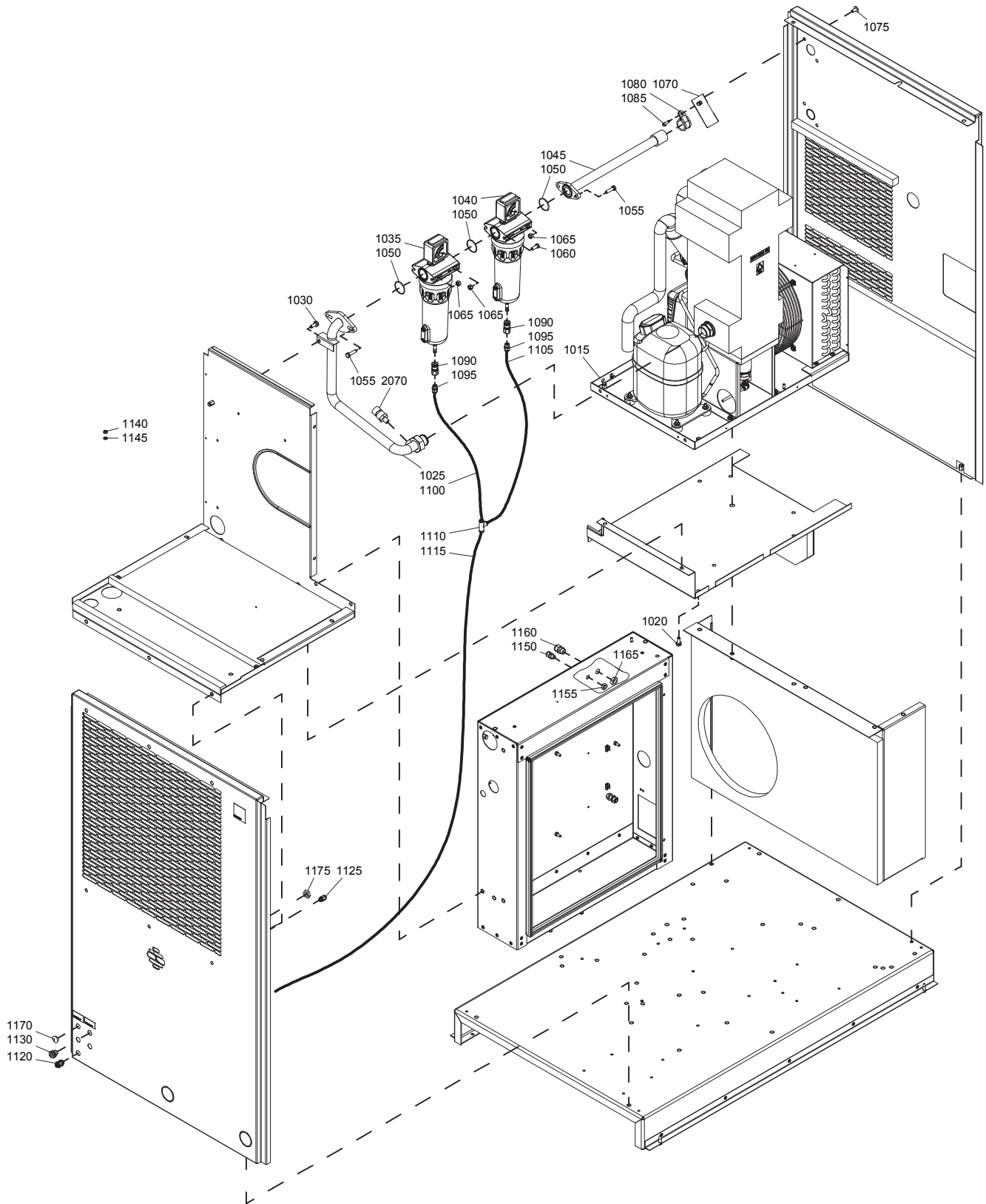

Standard option - DD/PD filter - GA 18 VSD, GA 22 VSD, GA 26 VSD, GA 30 VSD

18

Ref.	Part number	Qty	Name	Remarks
		1	Standard option	
			DD/PD filter	
	8092 2911 22		GA 18 VSD (ID60) no 200V/50Hz	
	8092 2911 22		GA 18 VSD (ID60) no 200V/60Hz	
	8092 2911 22		GA 18 VSD (ID71) 200V/50Hz	
	8092 2911 22		GA 18 VSD (ID71) 200V/60Hz	
	8092 2911 22		GA 22 VSD (ID71) no 200V/50Hz	
	8092 2911 22		GA 22 VSD (ID71) no 200V/60Hz	
	8092 2911 22		GA 22 VSD (ID71) 200V/50Hz	
	8092 2911 22		GA 22 VSD (ID71) 200V/60Hz	
	8092 2911 30		GA 26 VSD (ID93) no 200V/50Hz	
	8092 2911 30		GA 26 VSD (ID93) no 200V/60Hz	
	8092 2911 30		GA 26 VSD (ID93) 200V/50Hz	
	8092 2911 30		GA 26 VSD (ID93) 200V/60Hz	
	8092 2911 30		GA 30 VSD (ID93) no 200V/50Hz	
	8092 2911 30		GA 30 VSD (ID93) no 200V/60Hz	
	8092 2911 30		GA 30 VSD (ID93) 200V/50Hz	
	8092 2911 30		GA 30 VSD (ID93) 200V/60Hz	
0035	<<< >>>	• 1	DD filter	
0040	<<< >>>	• 1	PD filter	
0045		• 1	Pipe	
	1625 7970 00		PD 60/DD 60	
	1625 7980 00		PD 120/DD 120	
0050		• 3	O-ring	
	0663 2101 97		PD 60/DD 60	
	0663 2104 75		PD 120/DD 120	
0055	0147 1326 03	• 4	Hexagon bolt	
0060	0215 0003 73	• 2	Screw	
0065	0266 2110 00	• 6	Nut	
0070	1622 7881 00	• 1	Support	
0075	0215 0006 14	• 2	Screw	
0080	0346 1002 10	• 1	Pipe clamp	
0085	0211 1965 60	• 1	Hexagon bolt	
1090	1617 7082 02	• 2	Coupling	
0095	0583 8100 69	• 2	Coupling	
0100	0070 6002 05	• AR	Plastic tube	
0105	0070 6002 05	• AR	Plastic tube	
0110	0583 8140 50	• 1	Tee	
0115	0070 6002 05	• AR	Plastic tube	
0120	0583 8100 70	• 3	Coupling	
1125	0583 8100 66	• 1	Fitting	
1130	0581 0000 43	• 1	Coupling	
1140	0266 2108 00	• 2	Nut	
1145	0301 2321 00	• 2	Washer	
1150	0698 5140 70	• 1	Cable gland	
1155	0697 9809 30	• 1	Lock nut	
1160	0698 5140 71	• 1	Cable gland	
1165	0697 9809 20	• 1	Lock nut	
1170	0697 9810 25	• 1	Plug	
1175	0697 9809 20	• 1	Lock nut	
2070	1089 0575 54	• 1	Pressure transducer	

19

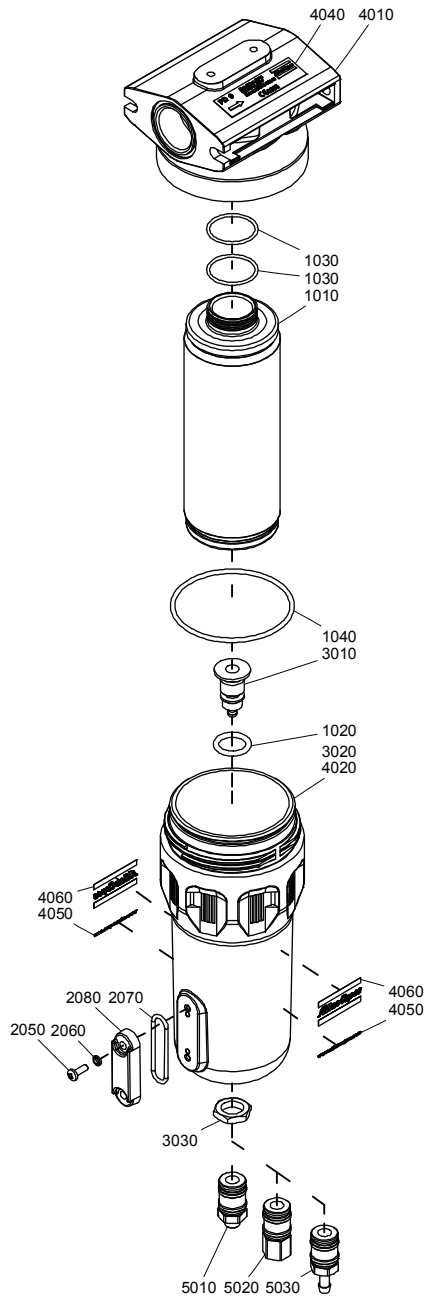

Standard option - DD/PD filter - Parts

19

Ref.	Part number	Qty	Name	Remarks
		1	Filter	
	8102 2601 25		DD 44	
	8102 2601 66		DD 60	
	8102 2602 08		DD 120	
	8102 2601 33		PD 44	
	8102 2601 74		PD 60	
	8102 2602 16		PD 120	
		• 1	Element kit	
	2901 0529 00		DD 44	
	2901 0529 00		DD 60	
	2901 0535 00		DD 120	
	2901 0530 00		PD 44	
	2901 0530 00		PD 60	
	2901 0536 00		PD 120	
1010		•• 1	Filter element	
1020	0663 2111 29	•• 1	O-ring	
1030		•• 2	O-ring	
	0663 2109 64		DD 44	
	0663 2109 64		DD 60	
	4090 0507 00		DD 120	
	0663 2109 64		PD 44	
	0663 2109 64		PD 60	
	4090 0507 00		PD 120	
1040		•• 1	O-ring	
	0663 2110 26		DD 44	
	0663 2110 26		DD 60	
	0663 2110 31		DD 120	
	0663 2110 26		PD 44	
	0663 2110 26		PD 60	
	0663 2110 31		PD 120	
	2901 0562 00	• 1	Sight glass kit	
2050		••	Screw	
2060		••	Seal washer	
2070	0663 9095 00	•• 1	O-ring	
2080		•• 1	Sight glass	
	2901 0563 00	• 1	Drain valve kit	
3010		•• 1	Drain valve	
3020	0663 2111 29	•• 1	O-ring	
3030	1617 7046 00	•• 1	Nut	
4010		• 1	Head	
4030		• 1	Bowl	
4040		• 2	Label	
	1617 7052 03		DD 44	
	1617 7052 07		DD 60	
	1617 7053 03		DD 120	
	1617 7052 01		PD 44	
	1617 7052 05		PD 60	
	1617 7053 01		PD 120	
4050		• 2	Label	
	1079 9926 35		DD 44	
	1079 9926 35		DD 60	
	1079 9926 36		DD 120	
	1079 9926 35		PD 44	
	1079 9926 35		PD 60	

19

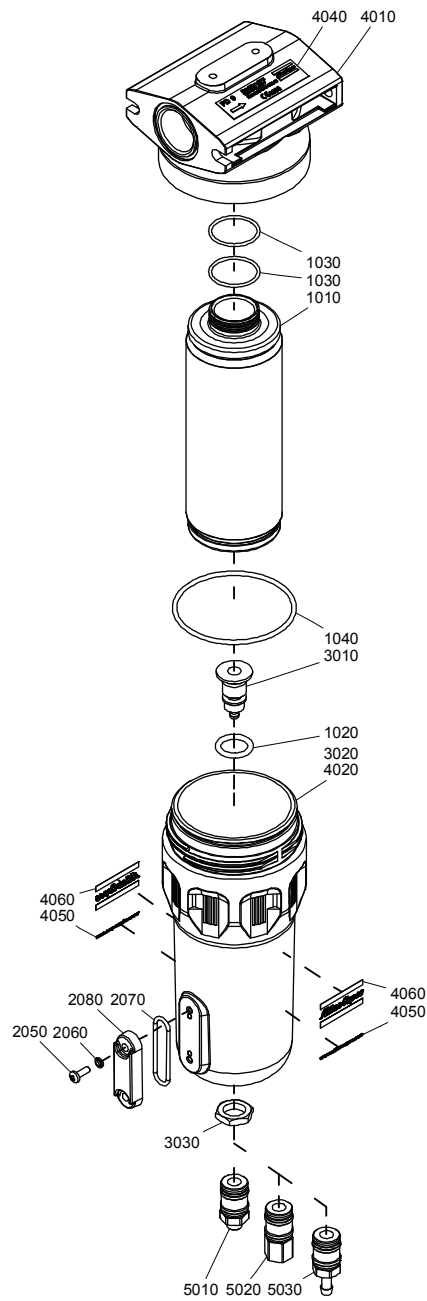

Standard option - DD/PD filter - Parts**19**

Ref.	Part number	Qty	Name	Remarks
4060	1079 9926 36	• 2	PD 120	
			House mark	
	0690 1106 01		DD 44	
	0690 1106 01		DD 60	
	0690 1101 23		DD 120	
	0690 1106 01		PD 44	
	0690 1106 01		PD 60	
	0690 1101 23		PD 120	
5010	1617 7082 01	1	Male coupling	
5020	1617 7082 02	1	Female coupling	
5030	1617 7082 03	1	Hose connection	

Standard option - Air dryer bypass - GA 15 VSD

20

Ref.	Part number	Qty	Name	Remarks
		1	Standard option	
			Air dryer bypass	
	8092 2910 80		ID46	
1005	0571 0036 01 •	1	Nipple	
1006	0663 3130 00 •	1	O-ring	
1010	1625 7011 00 •	1	Pipe	
1015	0226 0301 00 •	1	Screw	
1020	1613 7764 00 •	1	Ball valve	
1025	0571 0036 01 •	1	Nipple	
1030	0571 0036 31 •	2	Nipple	
1035	0663 3130 00 •	3	O-ring	
1040	0575 0125 52 •	1	Hose assembly	
1045	0575 0125 53 •	1	Hose assembly	
1050	1622 2733 00 •	1	Connector	
1055	0215 0006 14 •	2	Screw	
1060	0571 0036 31 •	1	Nipple	
1065	0663 3130 00 •	1	O-ring	
1070	0686 3718 24 •	2	Plug	

21

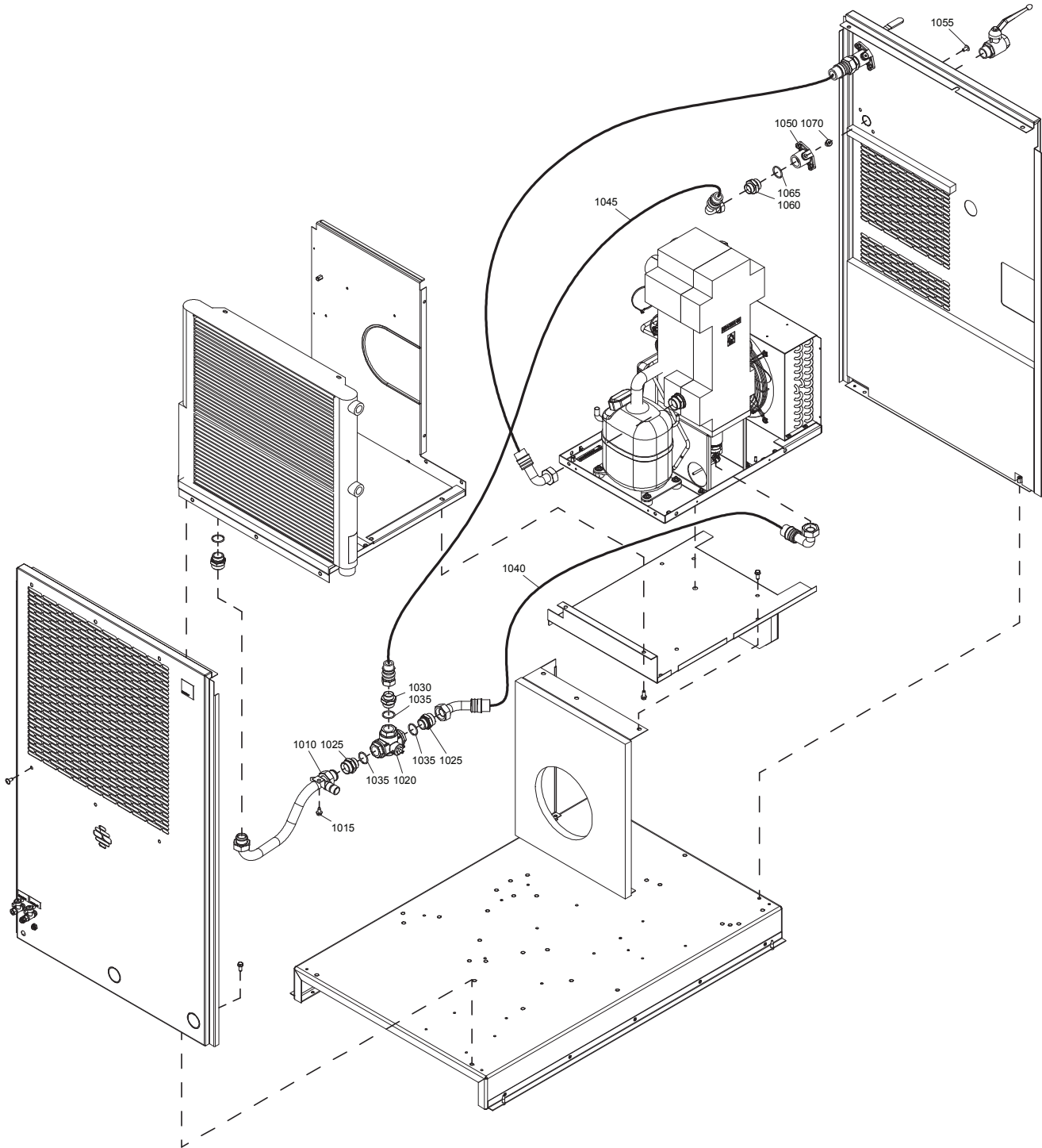

**Standard option - Air dryer bypass - GA 18 VSD, GA 22 VSD,
GA 26 VSD, GA 30 VSD**

21

Ref.	Part number	Qty	Name	Remarks
		1	Standard option	
			Air dryer bypass	
	8092 2910 98		ID60	
	8092 2910 98		ID71	
	8092 2910 98		ID93	
1010	1625 7011 00 •	1	Pipe	
1015	0226 0301 00 •	1	Screw	
1020	1613 7764 00 •	1	Ball valve	
1025	0571 0036 01 •	2	Nipple	
1030	0571 0036 31 •	1	Nipple	
1035	0663 3130 00 •	3	O-ring	
1040	0575 0796 14 •	1	Hose assembly	
1045	0575 0125 53 •	1	Hose assembly	
1050	1622 2733 00 •	1	Connector	
1055	0215 0006 14 •	2	Screw	
1060	0571 0036 31 •	1	Nipple	
1065	0663 3130 00 •	1	O-ring	
1070	0686 3718 15 •	1	Plug	

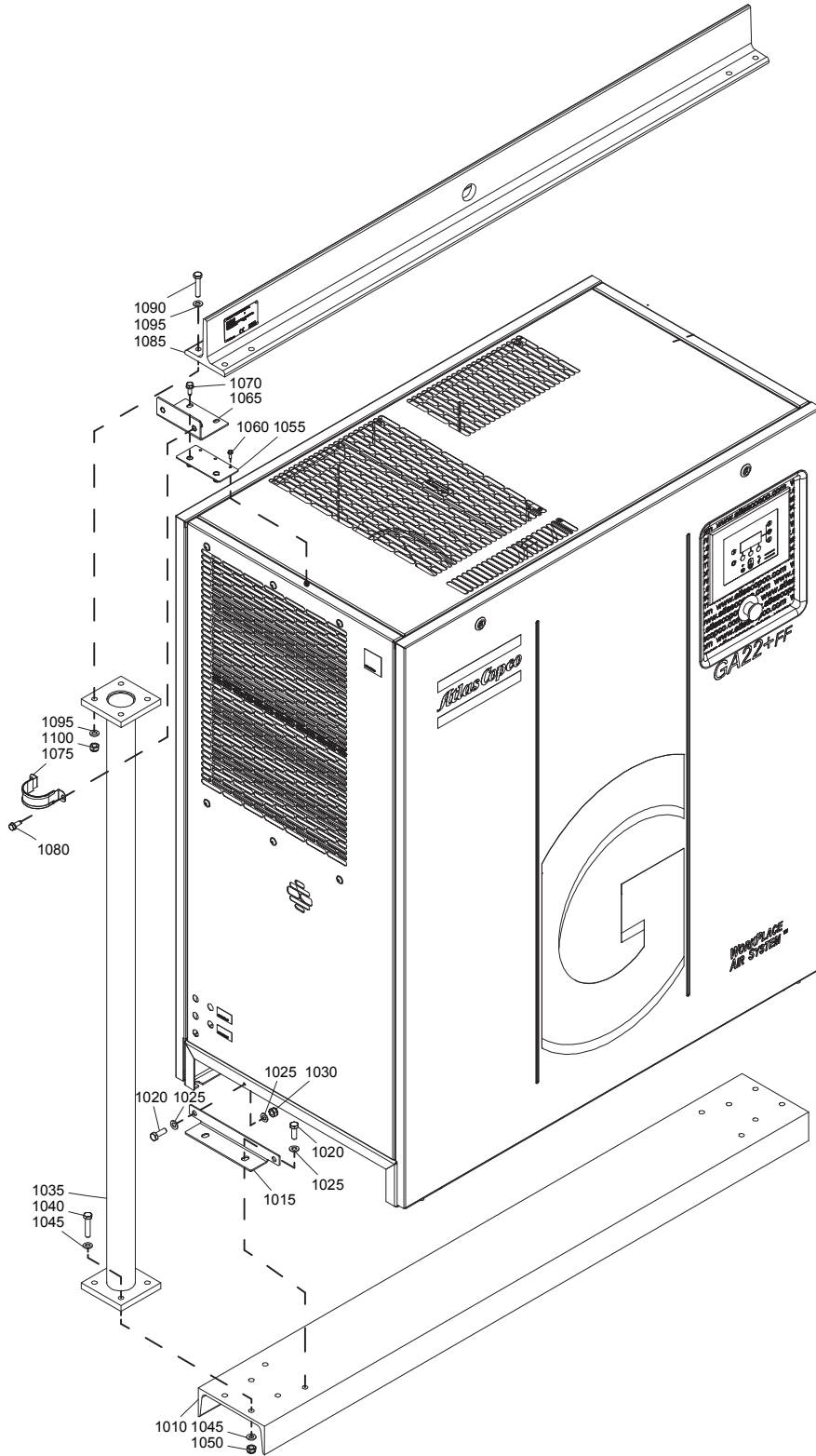

Standard option - Lifting device

22

Ref.	Part number	Qty	Name	Remarks
		1	Standard option	
	8092 2902 72		Lifting device	
1010	1622 7893 80 •	1	Beam	
1015	1622 7896 80 •	2	Support	
1020	0147 1363 03 •	8	Hexagon bolt	
1025	0301 2344 00 •	12	Washer	
1030	0291 1111 00 •	4	Lock nut	
1035	1622 7891 80 •	2	Support	
1040	0147 1367 03 •	8	Hexagon bolt	
1045	0301 2344 00 •	16	Washer	
1050	0291 1111 00 •	8	Lock nut	
1055	1622 7888 80 •	2	Support	
1060	1079 2263 02 •	6	Screw	
1065	1622 7883 80 •	2	Support	
1070	0147 1963 08 •	4	Hexagon bolt	
1075	0346 1000 51 •	2	Clamp	
1080	0147 1963 08 •	4	Hexagon bolt	
1085	1622 7892 80 •	1	Beam	
1090	0147 1367 03 •	8	Hexagon bolt	
1095	0301 2344 00 •	16	Washer	
1100	0291 1111 00 •	8	Lock nut	

23

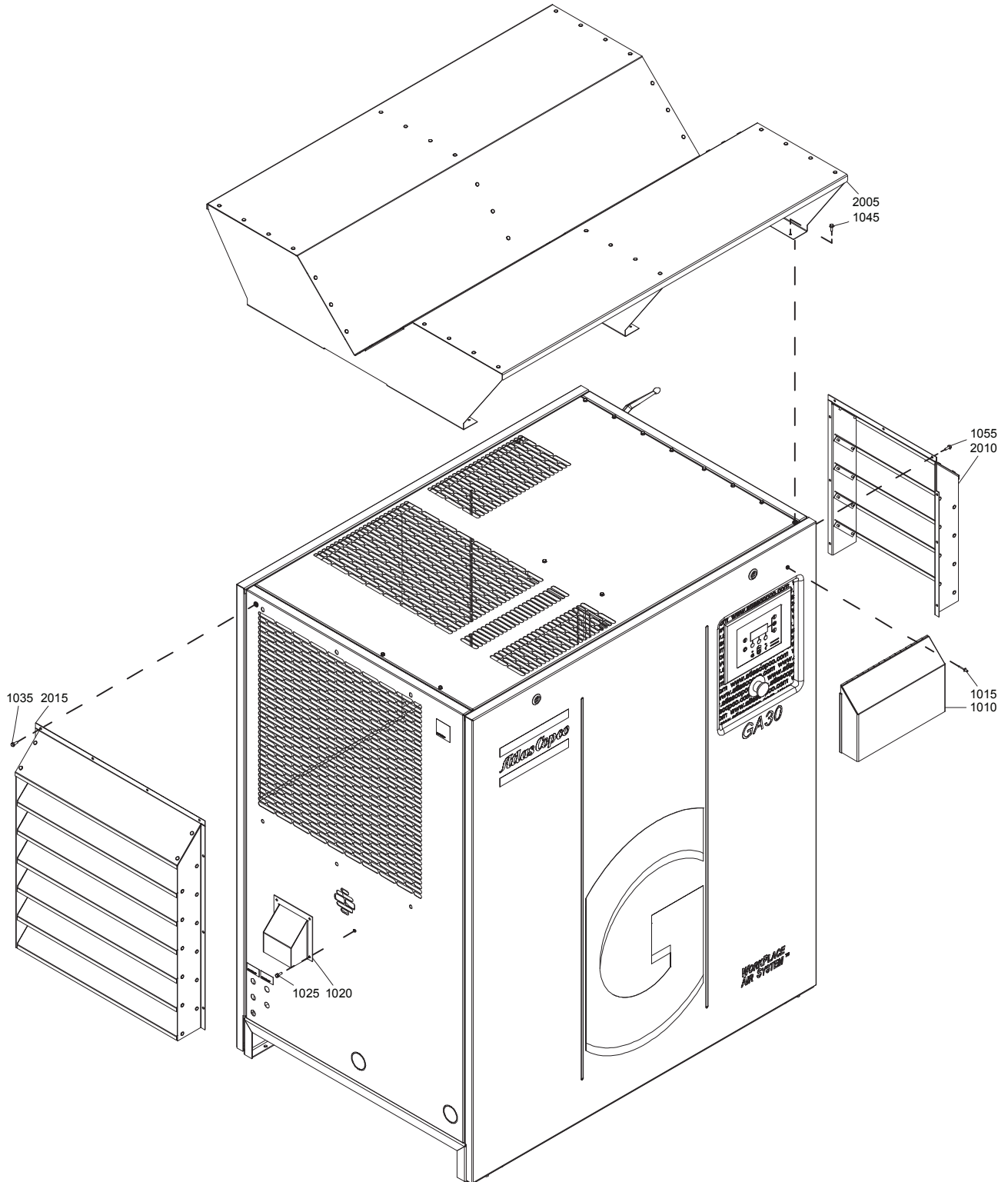

Standard option - Rain protection

23

Ref.	Part number		Qty	Name	Remarks
			1	Standard option	
				Rain protection	
1010	1613 8138 80	•	1	Baffle	
	1503 1056 00	••	AR	Seal	
1015	0129 3270 33	•	3	Screw	
1020	1622 6472 80	•	1	Baffle	
1025	1079 2263 02	•	4	Screw	
1035	1079 2263 02	•	10	Screw	
1045	1079 2263 02	•	24	Screw	
1055	1079 2263 02	•	9	Screw	
	1622 7929 80	•	1	Rain protection set	
2005	1622 7889 80	••	1	Baffle	
2010	1622 7895 80	••	1	Cowl	
2015	1622 7898 80	••	1	Cowl	

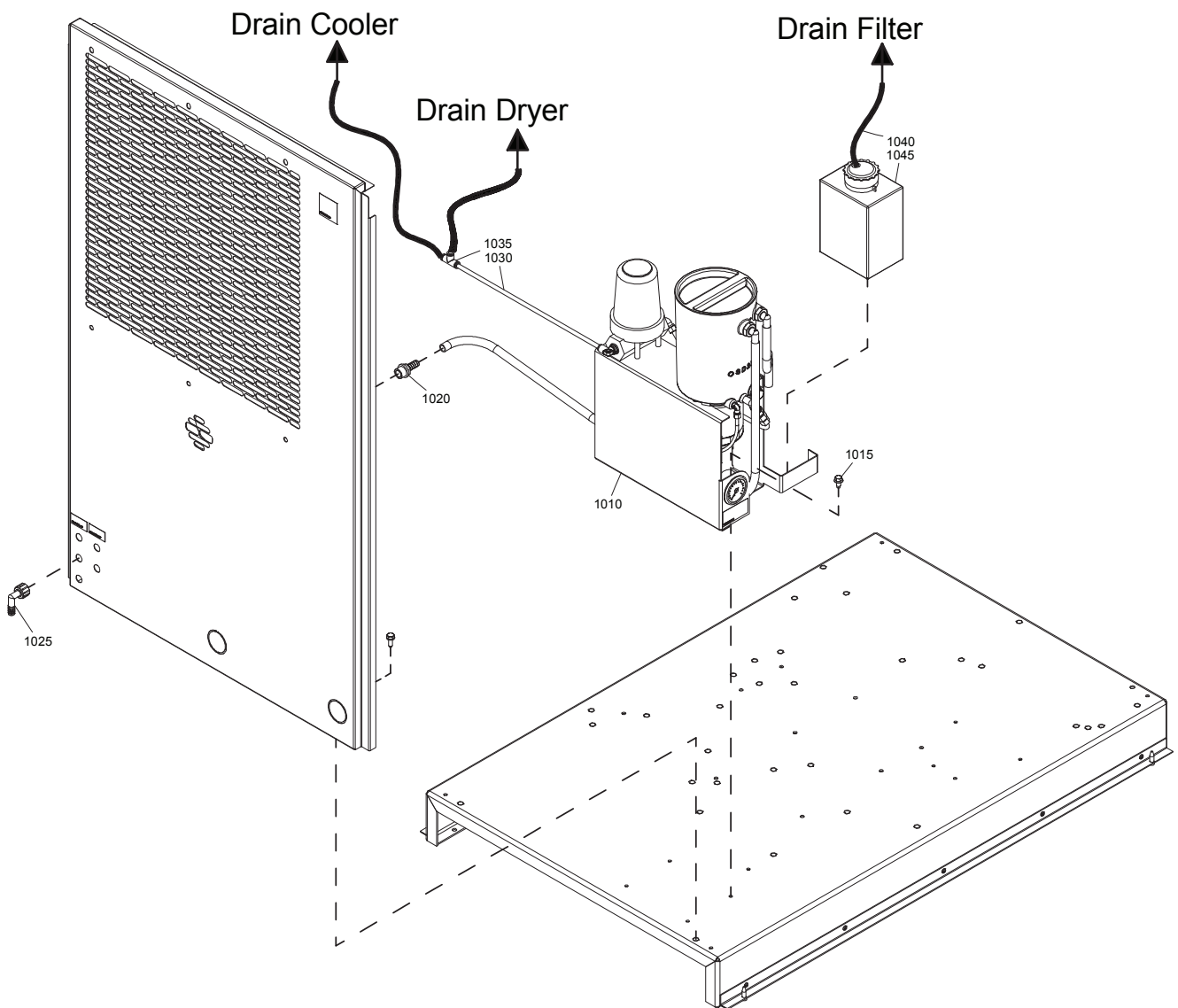

Standard option - Oil separator condensate drain

24

Ref.	Part number	Qty	Name	Remarks
	8092 2912 54	1	Standard option	
				Oil separator condensate drain
1010	<<< >>>	• 1	OSD assembly	
1015	0226 0301 00	• 3	Screw	
1020	1613 7341 00	• 1	Pipe coupling	
1025	1613 7342 00	• 1	Elbow coupling	
1030	0070 6002 05	• AR	Plastic tube	
1035	0583 8140 50	• 1	Tee	
1040	0070 6002 05	• AR	Plastic tube	
1045	1613 9735 80	• 1	Oil reservoir	

25

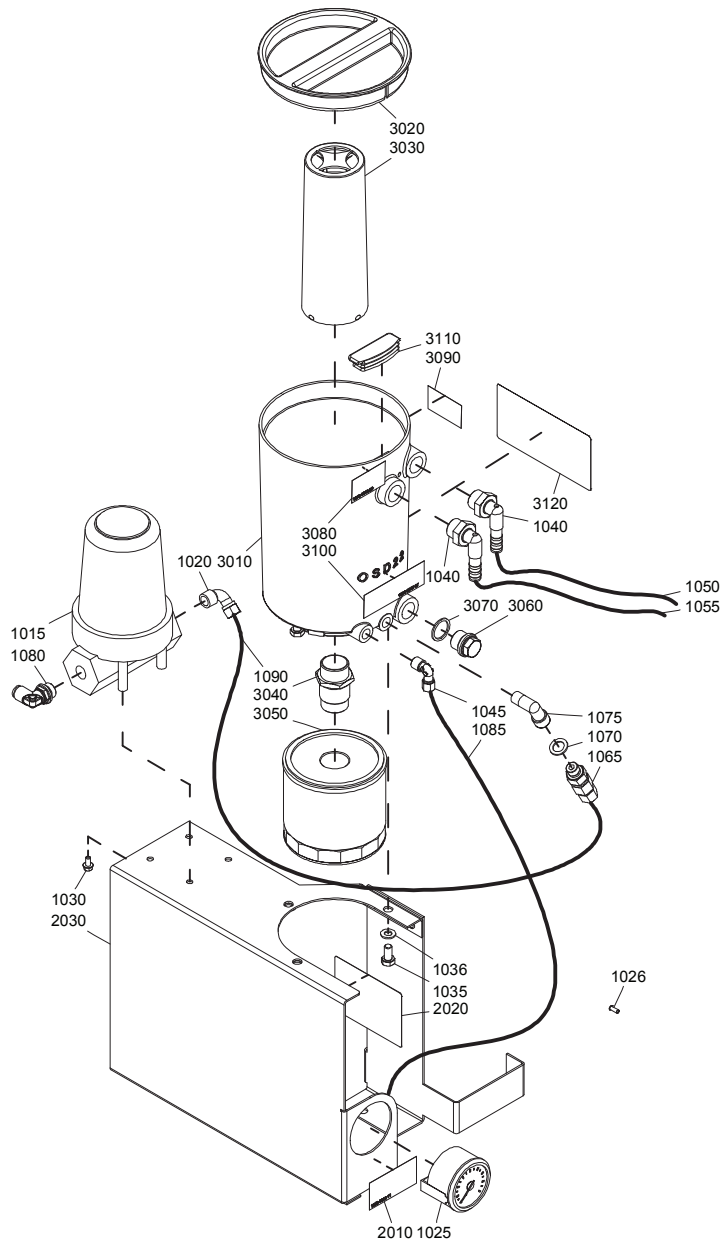

Standard option - Oil separator condensate drain - Parts

25

Ref.	Part number	Qty	Name	Remarks
	8092 2912 54	1	Standard option	
		1	Oil separator drain - OSD 22	
1015	1613 7865 81	• 1	Filter	
	0663 2104 06	•• 1	O-ring	
	1613 7864 00	•• 1	Filter element	
1020	0581 1200 37	• 1	Pipe coupling	
1025	1615 7264 00	• 1	Pressure gauge	
1026	0584 9904 00	• 1	Sleeve	
1030	0226 0326 00	• 4	Screw	
1035	0147 1322 03	• 3	Hexagon bolt	
1036	0301 2335 00	• 3	Washer	
1040	1613 7985 80	• 2	Elbow coupling	
1045	0581 1200 28	• 1	Coupling	
1050	0070 6002 05	• AR	Plastic tube	
1055	0070 6002 14	• AR	Plastic tube	
1065	1613 7378 01	• 1	Strainer	
1070	0653 0500 47	• 1	Gasket	
1075	1503 2565 02	• 1	Bend	
1080	0583 8120 76	• 1	Fitting tube	
1085	0070 6002 04	• AR	Plastic tube	
1090	0070 6002 14	• AR	Plastic tube	
	1625 7014 80	• 1	Support	
2010	1079 9912 11	•• 1	Decal	
2020	1622 1900 11	•• 1	Decal	
2030		•• 1	Support	
	1613 7603 84	• 1	OSD assembly	
3010		•• 1	Housing	
3020	1613 7604 00	•• 1	Plug	
3030	1613 7299 00	•• 1	Filter	
3040	1613 7601 00	•• 1	Check valve	
3050	1613 7602 00	•• 1	Oil separator	
3060	0686 3716 02	•• 1	Hexagon plug	
3070	0653 9098 00	•• 1	Flat gasket	
3080	1079 9913 69	•• 1	Information label	
3090	1079 9912 28	•• 1	Decal	
3100	1079 9912 07	•• 1	Decal	
3110	1613 7945 00	•• 1	Plug	
3120	1079 9909 06	•• 1	Label	

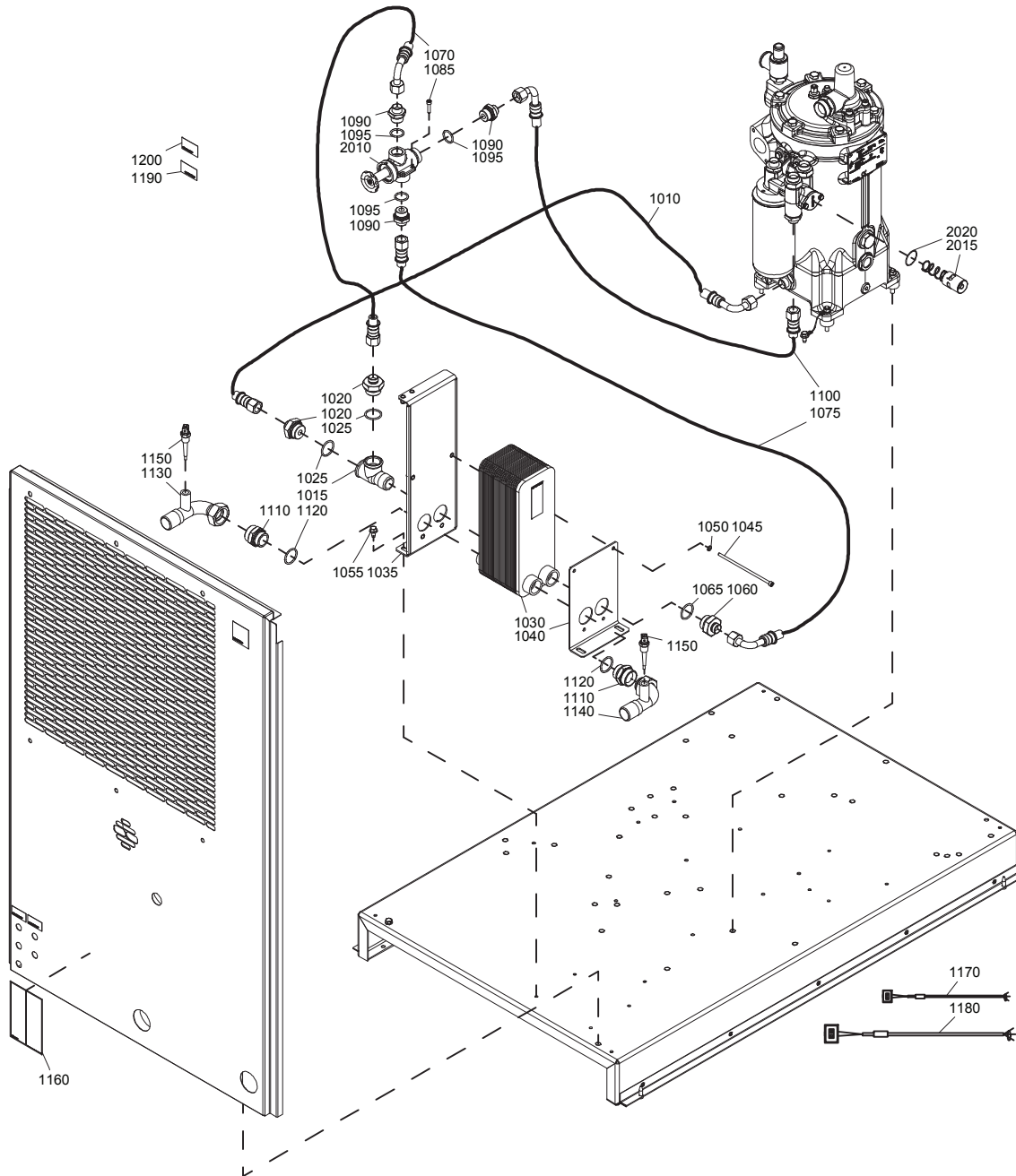

Standard option - Energy recovery system

26

Ref.	Part number	Qty	Name	Remarks
	8092 2912 39	1	Standard option	
			Energy recovery	
1010	0574 9911 47 •	1	Hose assembly	
1015	0560 4401 31 •	1	Tee	
1020	0571 0036 24 •	2	Nipple	
1025	0663 3130 00 •	2	O-ring	
1030	1625 7015 00 •	1	Heat exchanger	
1035	1622 6952 80 •	1	Support	
1040	1622 6953 00 •	1	Support	
1045	0211 1102 26 •	4	Screw	
1050	0301 2321 00 •	4	Washer	
1055	0226 0301 00 •	4	Screw	
1060	0571 0036 24 •	1	Nipple	
1065	0663 3130 00 •	1	O-ring	
1070	0574 9911 47 •	1	Hose assembly	
1075	0574 9911 14 •	1	Hose assembly	
1085	0211 1965 60 •	2	Hexagon bolt	
1090	0571 0035 97 •	3	Nipple	
1095	0663 2113 37 •	3	O-ring	
1100	0574 9911 14 •	1	Hose assembly	
1110	0571 0036 01 •	2	Nipple	
1120	0663 3130 00 •	2	O-ring	
1130	1622 7884 00 •	1	Pipe coupling	
1140	1622 7884 10 •	1	Pipe coupling	
1150	1089 0574 70 •	2	Temp. sensor	
1160	1622 5529 00 •	1	Label	
1170	1622 0663 06 •	1	Cable temp. sensor	
1180	1622 0663 07 •	1	Cable temp. sensor	
1190	1079 9913 79 •	1	Information label	
1200	1079 9913 69 •	1	Information label	
2010	1622 7990 81 •	1	Valve assy	
2015	1622 7064 03 •	1	Thermostatic valve 75°C	
2020	0663 2101 95 •	1	O-ring	

27

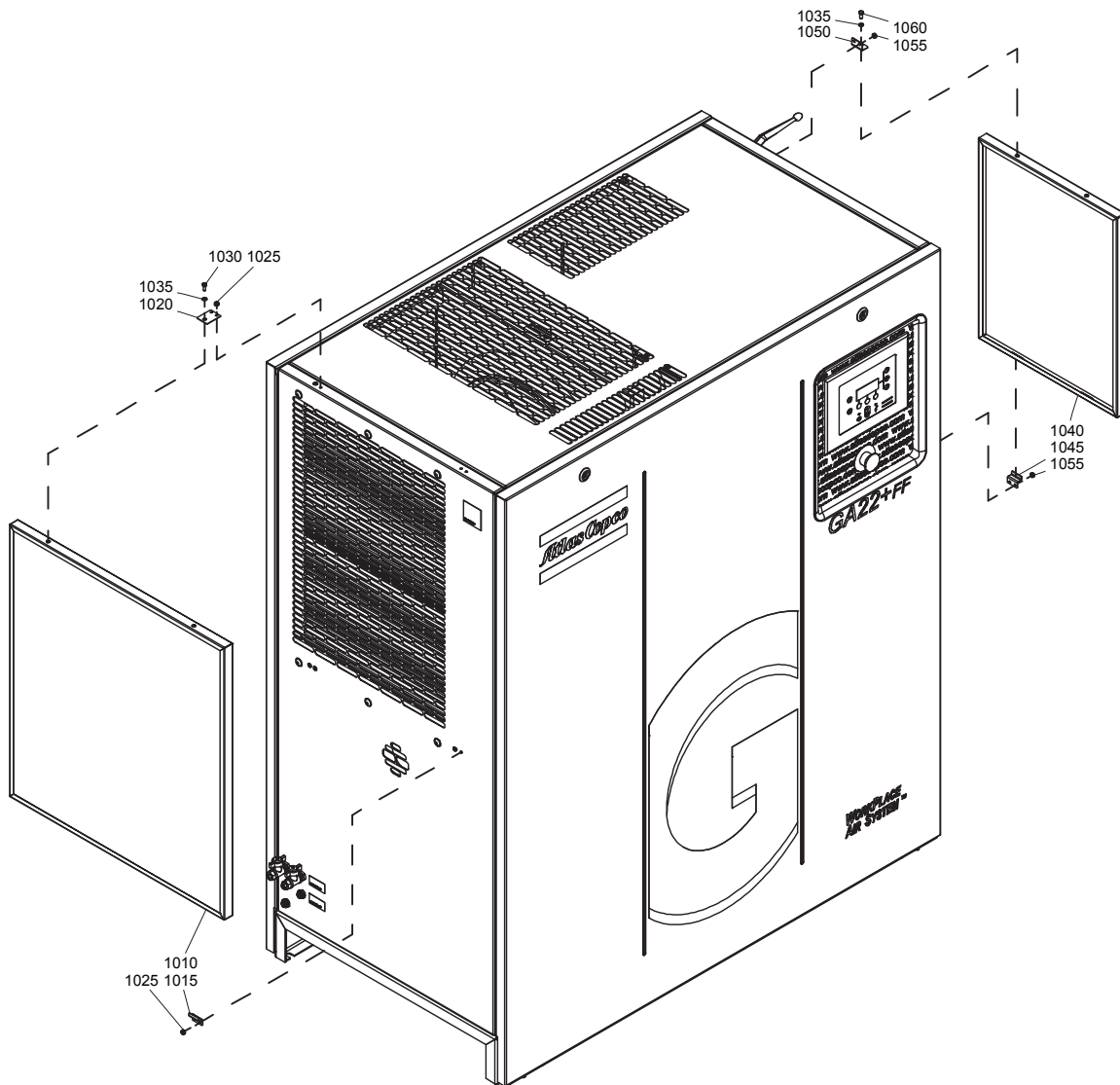

Standard option - Pre-filter**27**

Ref.	Part number	Qty	Name	Remarks
	8092 2911 89	1	Standard option	
			Pre-filter	
1010	1622 8508 06 •	1	Filter	
1015	1622 8512 02 •	2	Support	
1020	1625 7045 00 •	2	Support	
1025	0129 3121 00 •	8	Rivet	
1030	0147 1205 03 •	2	Hexagon bolt	
1035	0301 2318 00 •	4	Washer	
1040	1622 8508 07 •	1	Filter	
1045	1622 8512 02 •	2	Support	
1050	1622 8513 02 •	2	Support	
1055	0129 3121 00 •	8	Rivet	
1060	0147 1205 03 •	2	Hexagon bolt	

28

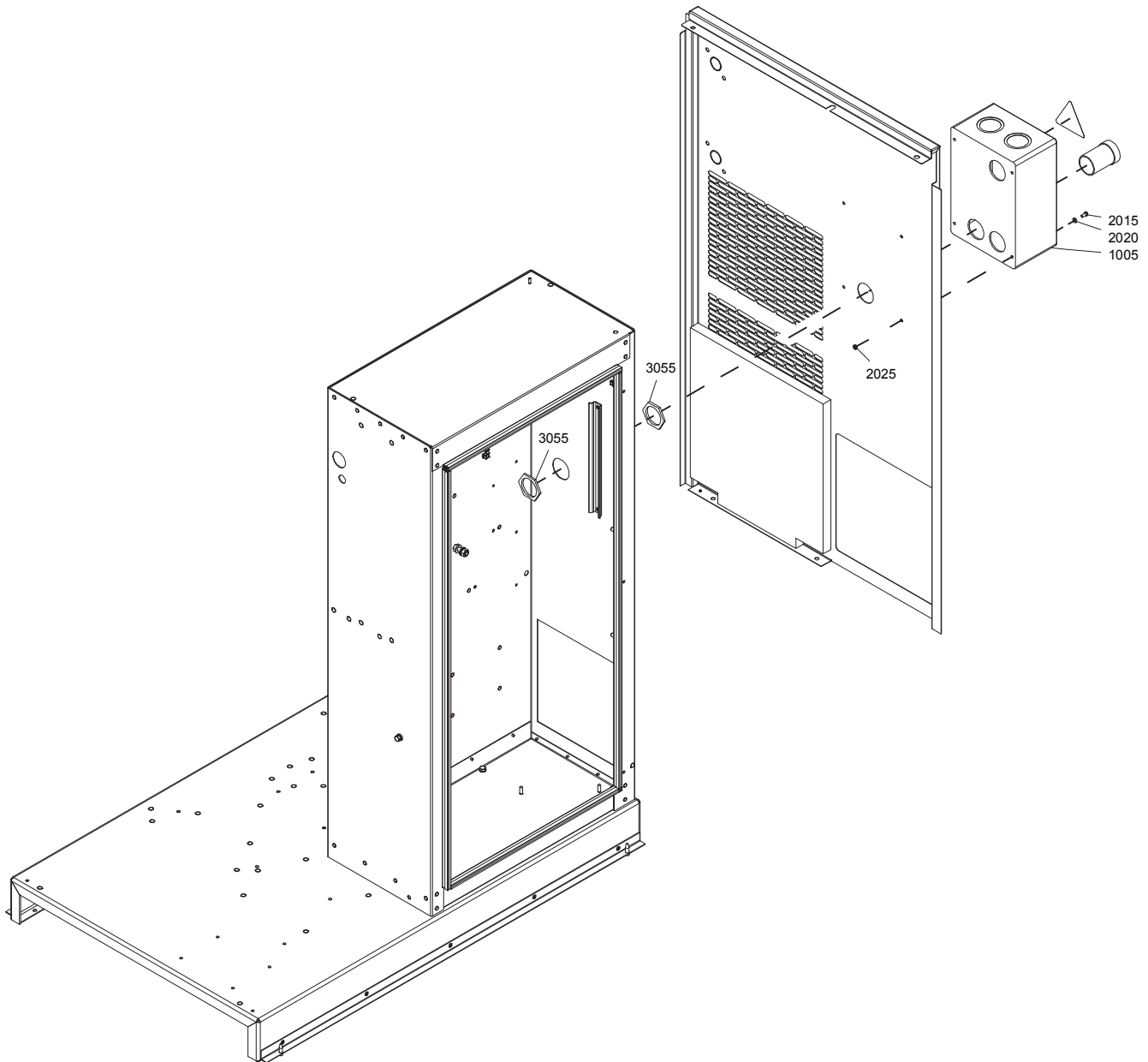

Standard option - Main switch**28**

Ref.	Part number	Qty	Name	Remarks
	8092 2913 46	1	Standard option	
			Main switch	
1005	1625 7019 03 •	1	Main switch	
2015	0160 6081 00 •	4	Screw	
2020	0301 2321 00 •	4	Washer	
2025	0261 2108 00 •	4	Nut	
3055	0697 9809 05 •	2	Nut	

In order to be First in Mind—First in Choice® for all your quality compressed air needs, Atlas Copco delivers the products and services that help to increase your business' efficiency and profitability.

Atlas Copco's pursuit of innovation never ceases, driven by our need for reliability and efficiency. Always working with you, we are committed to providing you the customized quality air solution that is the driving force behind your business.

