



»»» Instruction
Book



AVAILABILITY SERVICEABILITY
PARTNERSHIP RELIABILITY
SIMPLICITY

**TECHNOLOGY
YOU CAN
TRUST**



CECCATO

Oil-injected rotary screw compressors

CSMV10, CSMV15, CSMV20, CSMV25, CSMV30 , CSMV40, CSMV50

Instruction book

Original instructions

Copyright notice

Any unauthorized use or copying of the contents or any part thereof is prohibited.
This applies in particular to trademarks, model denominations, part numbers and drawings.

2020 - 10
No. 1641 003 740
www.ceccato.com



CONTENTS

PART A: INFORMATION FOR THE USER

- 1.0 GENERAL CHARACTERISTICS
- 2.0 INTENDED USE
- 3.0 OPERATION
- 4.0 GENERAL SAFETY STANDARDS
- 5.0 DESCRIPTION OF DANGER SIGNALS
- 6.0 DANGER ZONES
- 7.0 SAFETY DEVICES
- 8.0 POSITION OF PLATES
- 9.0 COMPRESSOR ROOM
- 10.0 TRANSPORT AND HANDLING
- 11.0 UNPACKING
- 12.0 INSTALLATION
- 13.0 DIMENSIONS AND TECHNICAL DATA
- 14.0 MACHINE ILLUSTRATION
- 15.0 ORDINARY MAINTENANCE TO BE DONE BY THE USER
- 16.0 PERIODS OF INACTIVITY
- 17.0 SCRAPPING THE UNIT
- 18.0 LIST OF SPARE PARTS FOR ROUTINE MAINTENANCE
- 19.0 TROUBLE-SHOOTING AND EMERGENCY REMEDIES

PART B: INFORMATION RESERVED FOR TECHNICALLY SKILLED PERSONNEL

- 20.0 STARTING UP
- 21.0 GENERAL ORDINARY MAINTENANCE REQUIRES TRAINED PERSONNEL
- 22.0 CHANGING THE OIL
- 23.0 REPLACE THE DE-OILER FILTER AND THE OIL FILTER
- 24.0 SYSTEM DIAGRAM

ADDRESSES OF ASSISTANCE CENTRES

In the event of breakdown or malfunction of the machine, switch it off and do not tamper with it.
If repairs are needed, apply only to a technical assistance centre approved by the manufacturer and insist on the use of original spare parts.
Failure to comply with the above may endanger the safety of the machine.

INTRODUCTION

Keep this manual with care for future consultation; the use and maintenance manual is an integral part of the machine.

**Read this manual carefully before carrying out any operations on the compressor unit.
The installation of the compressor unit and all operations involving it must be performed in conformity with the regulations in force concerning electric plants and personal safety.**

CHARACTERISTICS AND SAFETY PRECAUTIONS



MACHINE WITH AUTOMATIC START



BEFORE REMOVING THE PROTECTION DEVICES FOR ANY MAINTENANCEWORK ON THE MACHINE, DISCONNECT THE ELECTRICAL POWER SUPPLY AND MAKE SURE THAT THERE IS NO INTERNAL RESIDUAL PRESSURE.

THE FAILED COMPLIANCE WITH THE INSTRUCTIONS CONTAINED IN THIS HANDBOOK DETERMINES THE EXPIRATION OF THE WARRANTY TERMS.

ALL WORK ON THE ELECTRIC PLANT, HOWEVER SLIGHT, MUST BE CARRIED OUT BY PROFESSIONALLY SKILLED PERSONNEL.

The manufacturer does not accept responsibility for damage caused as a result of negligence of failure to abide by the instructions given above.

THIS MACHINE IS NOT SUITABLE FOR EXTERNAL INSTALLATION

THIS MACHINE CORRESPOND TO THE ESSENTIAL SAFETY REQUIREMENTS FORESEEN FROM THE EUROPEAN STANDARD (98/37 CE), AND THE RULE EN 292

GENERAL SAFTY PRECAUTIONS

To be read attentively and acted accordingly before installing, operating, repairing or decommissioning the unit.

These recommendations apply to machinery processing or consuming air or inert gas.
Processing of any other gas requires additional safety precautions typical to the application, which are not included herein.

In addition to normal safety rules, which should be observed with stationary air compressors and equipment, the following safety directions and precautions are of significant importance.

When operating this unit, the operator must employ safe working practices and observe all related local work safety requirements and ordinances.

The owner and/or user are/is responsible for maintaining the unit in a safe operating condition. Parts and accessories must be replaced if unsuitable for safe operation.

Authorized, trained, competent personnel only shall perform installation, operation, maintenance or repair.
Any modification on the compressor must only be performed in agreement with Factory and under supervision of authorized, competent personnel.

If any statement in this book, especially with regard to safety, does not comply with local legislation, the stricter of the two shall apply.

These precautions are general and cover several machine types and equipment; hence some statements may not apply.

Installation

Apart from general engineering practice in conformity with the local safety regulations, the following directives are specially stressed:

- 1) A compressor shall be lifted only with adequate equipment in conformity with local safety rules. Please consult Factory to check if a dedicated lifting device is designed for this purpose. Loose or pivoting parts shall be securely fastened before lifting. It is strictly forbidden to dwell or stay in the risk zone under a lifted load. Lifting acceleration and retardation shall be kept within safe limits. Lifting tools and tackles shall be inspected before lifting.
Wear a safety helmet and safety shoes when working in the area of overhead or lifting equipment.
- 2) Any blanking flanges, plugs, caps and desiccant bags shall be removed before connecting up the pipes. Any device for protection during transport shall be removed. Distribution pipes and connections shall be of correct size and suitable for the working pressure. Undersized pipe or poor routing of pipe will degrade the performance of the compressor.
- 3) Place the unit where the air is as cool and clean as possible. If necessary, install a suction duct. Never obstruct the air inlet. Care shall be taken to minimize the entry of moisture with the inlet air. Stationary compressors are not designed for outdoor operation.
- 4) The aspired air shall be free from corrosive chemicals (e.g. sulfur), flammable fumes or vapors (e.g. paint solvents that can lead to internal fire or explosion) and abrasive or combustible dust.
- 5) Air-cooled units shall be installed in such a way that an adequate flow of cooling air is available and that the exhausted air does not recirculate to the inlet of the airfilter nor to the inlet of the cooling air flow.
- 6) Arrange the air intake so that loose clothing of people cannot be sucked in.
- 7) Ensure that the discharge pipe from the compressor to the after-cooler or air net is free to expand under heat and that it is not in contact with or close to flammable material.
- 8) No external force may be exerted on the air outlet valve; the connected pipe must be free of strain.
- 9) If remote control is installed, the unit shall bear an obvious sign reading: **“DANGER: This machine is remotely controlled and may start without warning.”**
As a further safeguard, persons switching on remotely controlled units shall take adequate precautions to ensure that there is no one checking on or working on the machine.

To this end, a suitable notice shall be affixed to the start equipment.
- 10) On units with automatic start-stop system, a sign stating, **“This machine may start without warning.”** Shall be attached near the instrument panel.
- 11) Manual valves shall be installed to isolate each compressor from other compressors or from the system air pressure. Non-return valves (check valves) shall not be relied upon for safely isolating pressure systems. A check valve in the air piping from the compressor can interfere with the proper operation of the compressor controls.
- 12) Never remove or tamper with the safety devices, guards or insulations fitted on the unit. Every pressure vessel or auxiliary installed outside the unit to contain air above atmospheric pressure shall be protected by a pressure-relieving device or devices as required.

- 13) Pipework or other parts with a temperature in excess of 70°C and which personnel in normal operation may accidentally touch, shall be guarded or insulated. The other high-temperature pipework shall be clearly marked.
- 14) If the ground is not level or can be subject to variable inclination, consult Factory before installation.
- 15) Never drill holes in an electrical cabinet. Small metallic burrs can cause short-circuits in electrical components.
- 16) Make sure to avoid condensation on electrical components (e.g. cubicle, Elektronikon and frequency converter).
- 17) To preserve the protection of the electric cabinet and to protect its components from dust from the environment and the entry of moisture in the electrical cabinet, it is absolutely necessary to use a proper cable gland when connecting the power supply cable to the compressor.
Use of an improper cable gland can result in damage to or failure of the equipment. This could also result in fire and fatalities and void any warranty.
- 18) For shipboard applications where variable inclination is expected, consult Factory's line of dedicated Marine equipment.
- 19) Avoid contact with sharp edges or hot surfaces to prevent damage to cable insulation.
- 20) The unit shall be protected against short circuits by fuses or adequate circuit breakers.
- 21) The customer shall provide a main disconnecting device in the compressor room.
- 22) Before initial start-up and after service interventions, make sure the following final inspection checks are made:
 - a. Inspect all electrical connections to verify there are no loose connections and all are tightened correctly.
 - b. Check for strain relief on the (main) power cables.
 - c. Verify that the power requirement for the unit has been provided for by referencing to the unit power label on the inside of the electrical cabinet door of the unit.
 - d. The branch circuit protection and supply cable size for the compressor must be sized to meet the power requirement per local electrical codes.
 - e. Verify that the unit is correctly grounded using the proper size of wire connected to a tested earth ground.

An improper electrical installation or defective grounding can result in damage to or failure of the equipment. This could also result in fire and fatalities and void any warranty.

- 23) Before initial start-up and after service interventions, make sure the following final mechanical inspection checks are made:
 - a) Inspect all connections to make sure they are tight, sealed and secured.
 - b) Visually inspect metal or nylon tubing located in the compressor. Tubes can come loose or get damaged in shipping. Verify the flexibility of the nylon tubes while inspecting for damage. Verify that all tubes are secure in their fittings to ensure that none might leak or come loose when the compressor is in operation.

Damaged or loose tubes can result in lubricant being sprayed on hot surfaces when the compressor is in operation and result in damage to the compressor or fire.

After inspection, the power can be put to the installed compressor. With the proper power applied, the rotation of the compressor and the cooling fan can be verified.

Operation

- 1) Air hoses shall be of correct size and suitable for the working pressure. Never use frayed, damaged or deteriorated hoses. Use only the correct type and size of hose end fittings and connections. When blowing through a hose or airline, ensure that the open end is held securely. A free end will whip and may cause injury. Make sure that a hose is fully depressurized before disconnecting it.
- 2) Never play with compressed air. Do not apply it to your skin or direct an air stream at people. Never use it to clean dirt from clothes. When using it to clean equipment, do so with extreme caution and use eye protection.
- 3) The compressor is not considered as capable of producing air for breathing quality. For breathing air quality, the compressed air must be adequately purified according to local legislation and standards.
- 4) Never operate the unit when there is a possibility of taking in flammable or toxic fumes.
- 5) Never operate the unit at pressures below or in excess of its limit ratings as indicated on the Principal Data sheet.
- 6) Keep all bodywork doors shut during operation. The door may be opened for short periods only, e.g. to carry out checks. Wear ear and eye protection when opening a door.
- 7) People staying in environments or rooms where sound pressure level reaches or exceeds 90dB(A) shall wear ear protection. Check local legislation if it overrules.
- 8) Periodically check that:
 - a. All guards are in place and securely fastened.
 - b. All hoses, tubes and / or pipes inside the unit are in good condition, secure and not rubbing.
 - c. There are no leaks.
 - d. All fasteners are tight.
 - e. All electrical cables are secure and in good order.
 - f. Safety valves and other pressure-relief devices are not obstructed by dirt or paint.
 - g. Air outlet valve and air net, i.e. pipes, couplings, manifolds, valves, hoses, etc. are in good repair, free of wear or abuse.
 - h. There is no excess of dust in the electrical cabinet.
- 9) If warm cooling air from compressors is used in heating systems, e.g. to warm up a workroom, take precautions against air pollution and possible contamination of the breathing air.
- 10) Do not remove any of or tamper with the sound-damping material.
- 11) All failures should be reported to the Factory service department.

Maintenance

Maintenance and repair work shall only be carried out under supervision of someone qualified for the job who is well versed with risks and safe procedure.

To maintain warranty and to insure the compressor operates correctly and safely, genuine parts must be used. Use of non-genuine parts, failure to correctly install equipment or perform recommended scheduled maintenance will void warranty and can result in damage to or failure of the equipment. This could also result in fire and fatalities.

Before performing any maintenance, stop the compressor, close the shut-off valve at the unit discharge, remove all electrical power from the equipment, verify the receiver tank on the unit is at zero pressure and let the machine cool down. Take positive precautions to ensure that the unit cannot be started inadvertently by following a lock-out tag-out procedure or equivalent local legal requirements. In addition, a warning sign bearing a legend such as “**work in progress; do not start**” shall be attached to the starting equipment.

- 1) Before removing any pressurized component, effectively isolate the unit from all sources of pressure and relieve the entire system of pressure and electrical power. Take positive precautions to ensure that the unit cannot be started inadvertently. In addition, a warning sign bearing a legend such as **“work in progress; do not start”** shall be attached to the starting equipment.
- 2) Protect hands to avoid injury from hot machine parts, e.g. during draining of oil.
- 3) Never use flammable solvents or carbon tetrachloride for cleaning parts. Take safety precautions against toxic vapors of cleaning liquids.
Never use caustic solvents, which can damage materials of the air net, e.g. polycarbonate bowls.
- 4) Scrupulously observe cleanliness during maintenance and repair. Keep dirt away by covering the parts and exposed openings with clean cloth, paper or tape. Make sure that no tools, loose parts or rags are left in or on the unit.
- 5) Never weld or perform any operation involving heat near the oil system.
Oil tanks must be completely purged, e.g. by steam-cleaning, before carrying out such operations. Never weld on, or in any way modify, pressure vessels.
Whenever there is an indication or any suspicion that an internal part of a machine is overheated, the machine shall be stopped but **no inspection covers shall be opened** before sufficient cooling time has elapsed; this to avoid the risk of spontaneous ignition of the oil vapor when air is admitted. **Never use a light source with open flame for inspecting the interior of a machine, pressure vessel, etc.**
- 6) Protect the motor, air filter, electrical and regulating components, etc. to prevent moisture from entering them, e.g. when steam-cleaning or due to condensation of humid ambient air.
- 7) If the branch circuit is provided using a fused disconnect to supply power to the compressor, then verify that all the fuses are of the same type and properly sized. If a circuit breaker is used to supply power, verify that it is properly sized.
- 8) Visually inspect and verify that the connections at the branch circuit protection device are tight and the wire insulation is not degraded.
- 9) Visually inspect the wire from the branch circuit protection device to the compressor starter to verify that it is sized correctly and in good order.
- 10) Verify that the power wire and ground connections at the compressor starter are tight and in good order.
- 11) Verify that the wire connections from the compressor starter to the compressor motor are tight and in good order.
- 12) Replace filters in the electrical cabinet when they are saturated with dust.
- 13) Check if the sealing of the electrical cabinet is in perfect condition. If not, replace it.
- 14) Inspect all tubing in the compressor for possible leaks or normal aging and replace with genuine parts if needed.
- 15) Verify if all tube fittings are tight and tubes are securely held in the fittings.
- 16) Also check all nylon tubes for chaffing, cracks and flexibility and replace with genuine parts to insure safe operation.
- 17) Drain any condensate that may have collected in the receiver tank.
- 18) Regularly check the drain hole of the receiver because this can be obstructed by internal corrosion.
- 19) Yearly inspect wallthickness of receivers. This can be compromised by internal corrosion and may result in an explosion.
- 20) Respect oil service intervals. **Oxidized oil will result in higher compressor temperatures that could result in damage to the machine and/or fire.** If necessary, take oil samples for evaluation and be sure

to mark with customer name, compressor model, compressor serial number and running hours of the compressor.

21) Replace oil with genuine compressor oil of the same type when needed.

Low quality oil and low oil level will result in oil foaming, oil carry over and higher compressor temperatures that could result in damage to the machine and/or fire.

22) Replace all consumables at recommended service intervals (or sooner if operating conditions warrant) for the specific product and usage or replace every 12 months.

23) Make sure that all sound-damping material, e.g. on the bodywork and in the air inlet and outlet systems of the compressor, is in good condition. If damaged, replace it by genuine material to prevent the sound pressure level from increasing.

24) Every time the separator element is renewed, examine the discharge pipe and the inside of the oil separator vessel for carbon deposits; if excessive, the deposits should be removed.

25) Before clearing the unit for use after maintenance or overhaul, check that operating pressures, temperatures and time settings are correct and that the control and shutdown devices function correctly. If removed, check that the coupling guard of the compressor drive shaft has been reinstalled.

26) The following safety precautions are stressed when handling refrigerant:

- a. Never inhale refrigerant vapors. Check that the working area is adequately ventilated; if required, use breathing protection.
- b. Always wear special gloves. In case of refrigerant contact with the skin, rinse the skin with water. If liquid refrigerant contacts the skin through clothing, **never tear of or remove** the latter; flush abundantly with fresh water over the clothing until all refrigerant is flushed away; then seek medical first aid.
- c. Always wear safety glasses.

Poor maintenance or use of non-genuine parts may cause equipment failure and possibly result in fire and fatalities and void any warranty.

Decommissioning

Before decommissioning, stop the compressor, close the shut-off valve at the unit discharge, remove all electrical power from the equipment, verify the receiver tank on the unit is at zero pressure and let the machine cool down. Take positive precautions to ensure that the unit cannot be started inadvertently. In addition, a warning sign bearing a legend such as **“work in progress; do not start”** shall be attached to the starting equipment.

- 1) Before performing other work on the compressor, remove the power cable from the power supply.
- 2) Before removing any pressurized component, effectively isolate the unit from all sources of pressure and relieve the entire system of pressure.
- 3) Protect hands to avoid injury from hot machine parts, e.g. during draining of oil.
- 4) Drain any condensate that may have collected in the receiver tank.
- 5) The following safety precautions are stressed when handling refrigerant:
 - a) Never inhale refrigerant vapors. Check that the working area is adequately ventilated; if required, use breathing protection.
 - b) Always wear special gloves. In case of refrigerant contact with the skin, rinse the skin with water. If liquid refrigerant contacts the skin through clothing, **never tear of or remove** the latter; flush abundantly with fresh water over the clothing until all refrigerant is flushed away; then seek medical first aid.

- c) Always wear safety glasses.
- 6) Dispose of the compressor according to local waste handling regulations.

When in question, contact your local Factory Service Centre.

1.0 GENERAL CHARACTERISTICS

The compressor units use single-stage screw rotary air compressors with oil injection.

The central unit comprises:

compressor; oil separator; oil cooler and output air cooler; fan; electric start; safety and regulation devices; instrument panel.

The system is self-bearing and does not require bolts or other devices to anchor it to the floor.

The unit is completely assembled in the factory; the necessary connections for setting it up are:

- connection to the power mains (see installation chapter)
- connection to the compressed air network (see installation chapter)

The compressor-motor unit is fitted on the machine chassis by means of flexible supports: this allows the compressor unit to be laid directly on the floor without any need of further vibration-damping systems.

2.0 INTENDED USE

The compressor has been built to supply compressed air for industrial use.

The machine cannot be used in premises where there is a risk of fire or explosion or where work is carried out which releases substances into the environment which are dangerous with regard to safety (for example: solvents, inflammable vapours, alcohol, etc.).

In particular the appliance cannot be used to produce air to be breathed by humans or used on direct contact with foodstuffs. These uses are allowed if the compressed air produced is filtered by means of a suitable filtering system (Consult the manufacturer for these special uses.)

This appliance must be used only for the purpose for which it was specifically designed.

All other uses are to be considered incorrect and therefore unreasonable.

The Manufacturer cannot be held responsible for any damage resulting from improper, incorrect or unreasonable use.

3.0 OPERATION

The compressor unit is directly connected to the electric motor.

The compressor unit takes in the outside air through the suction valve. The air taken in is filtered by panel pre-filter fitted on the panel of the external covering and by the filter cartridge fitted upstream from the suction valve. Inside the compressor unit, the air and the lubricating oil are compressed and sent to the oil separating filter where the oil is separated from the compressed air; the air is then filtered again by the oil separating cartridge to reduce the amount of suspended oil particles to a minimum. At this point the two flows (of oil and air) are sent to two separate coolers where they are cooled, using a flow of air taken from the environment by a special fan inside the machine.

The cooled oil returns to the circuit while the compressed air is sent to the using network.

4.0 GENERAL SAFETY STANDARDS

The appliance may be used only by specially trained and authorized personnel.

Any tampering with the machine or alterations not approved beforehand by the Manufacturer relieve the latter of responsibility for any damage resulting from the above actions.

The removal of or tampering with the safety devices constitutes a violation of the European Standards on safety.



ALL WORK ON THE ELECTRIC PLANT, HOWEVER SLIGHT, MUST BE CARRIED OUT BY PROFESSIONALLY SKILLED PERSONEL.

5.0 DESCRIPTION OF DANGER SIGNALS









- | | | | |
|---|-------------------------------|--|---------------------------------|
|  | 1) DANGEROUS ELECTRIC VOLTAGE |  | 5) HIGH PRESSURE |
|  | 2) AIR NOT FIT FOR BREATHING |  | 6) HOT PARTS |
|  | 3) NOISE |  | 7) MOVING PARTS |
|  | 4) FAN ROTATING |  | 8) FLUID EJECTION |
| | |  | 9) MACHINE WITH AUTOMATIC START |

FIG. 1

6.0 DANGERS ZONES

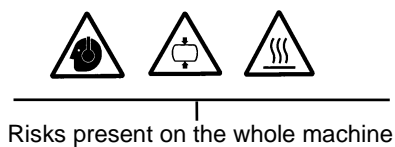
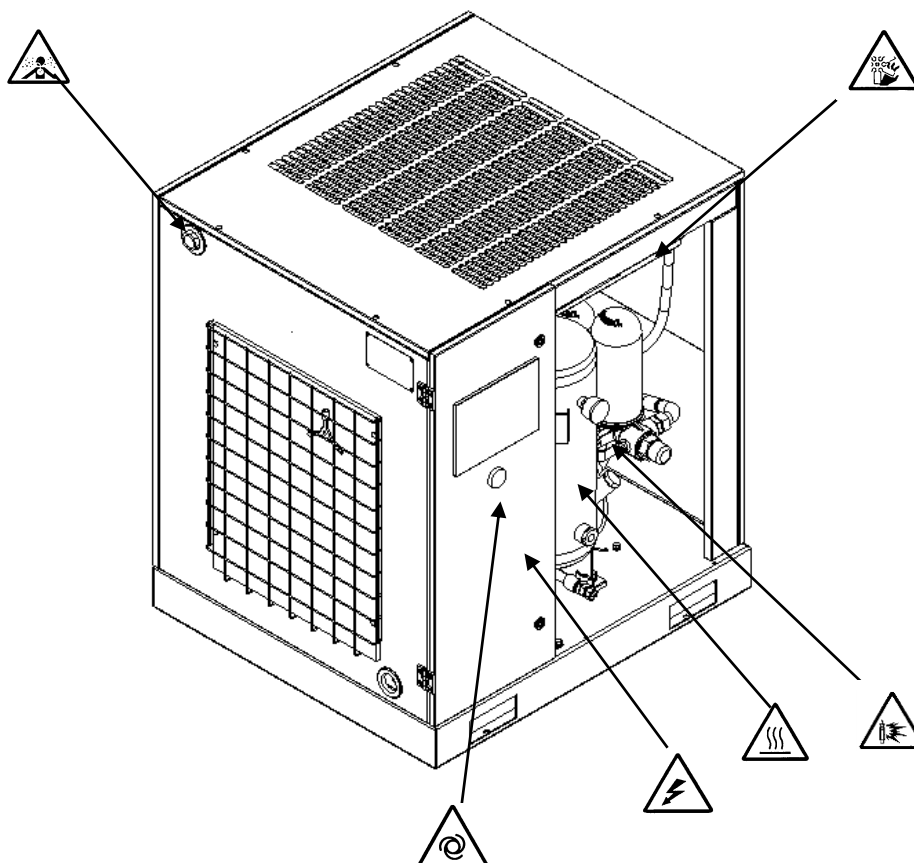
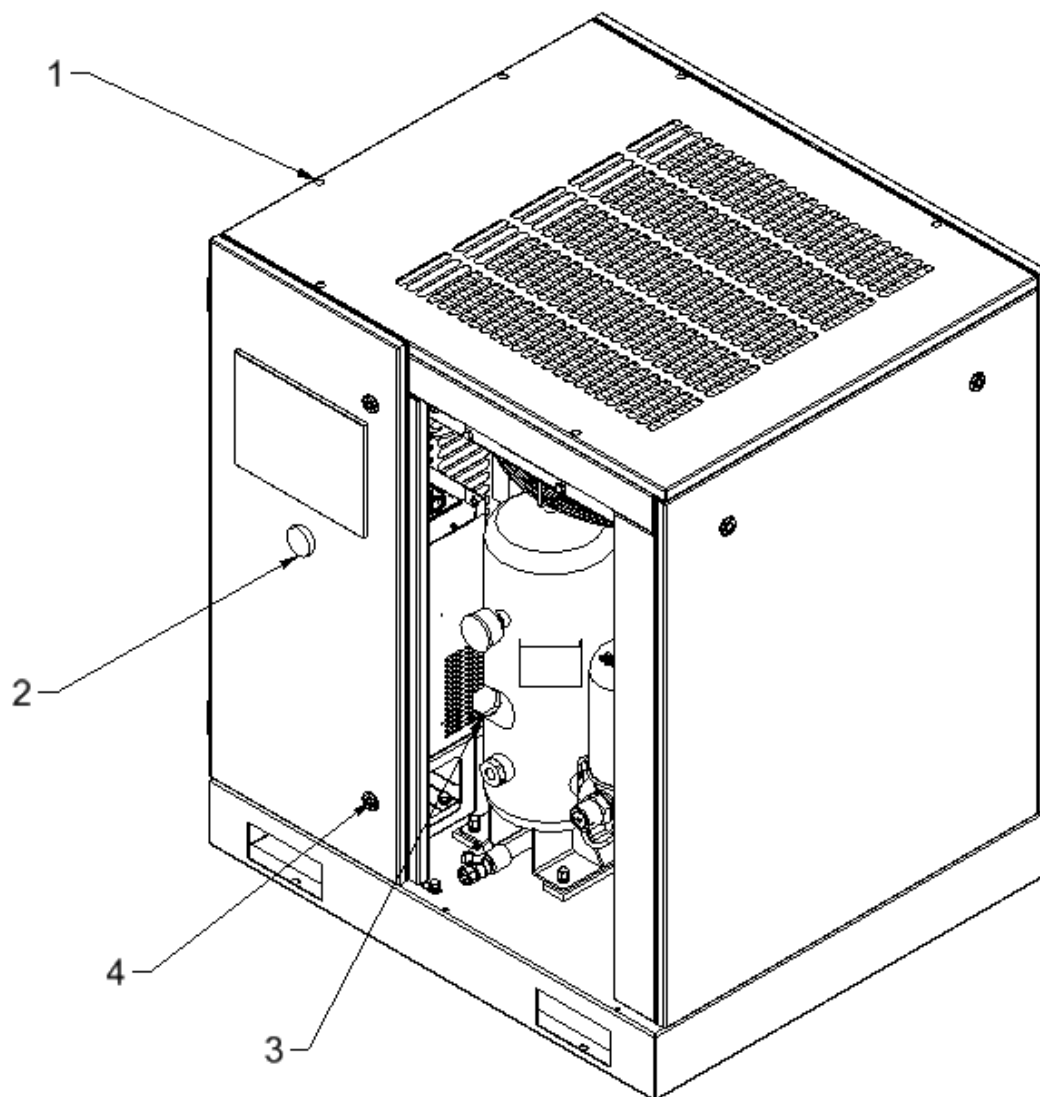

FIG. 2



7.0 SAFETY DEVICES

- 1) Safety screws
- 2) Oil filling cap (with safety breather)
- 3) Emergency stop
- 4) Side guard and electric board door can be opened using a special key.



8.0 POSITION OF PLATES**8.1 POSITION OF THE DANGER PLATES**

The plates fitted on the compressor unit are part of the machine; they have been applied for safety purposes and must not be removed or spoiled for any reason.

1) Plate "Machine with automatic start"

2) Dangers plate

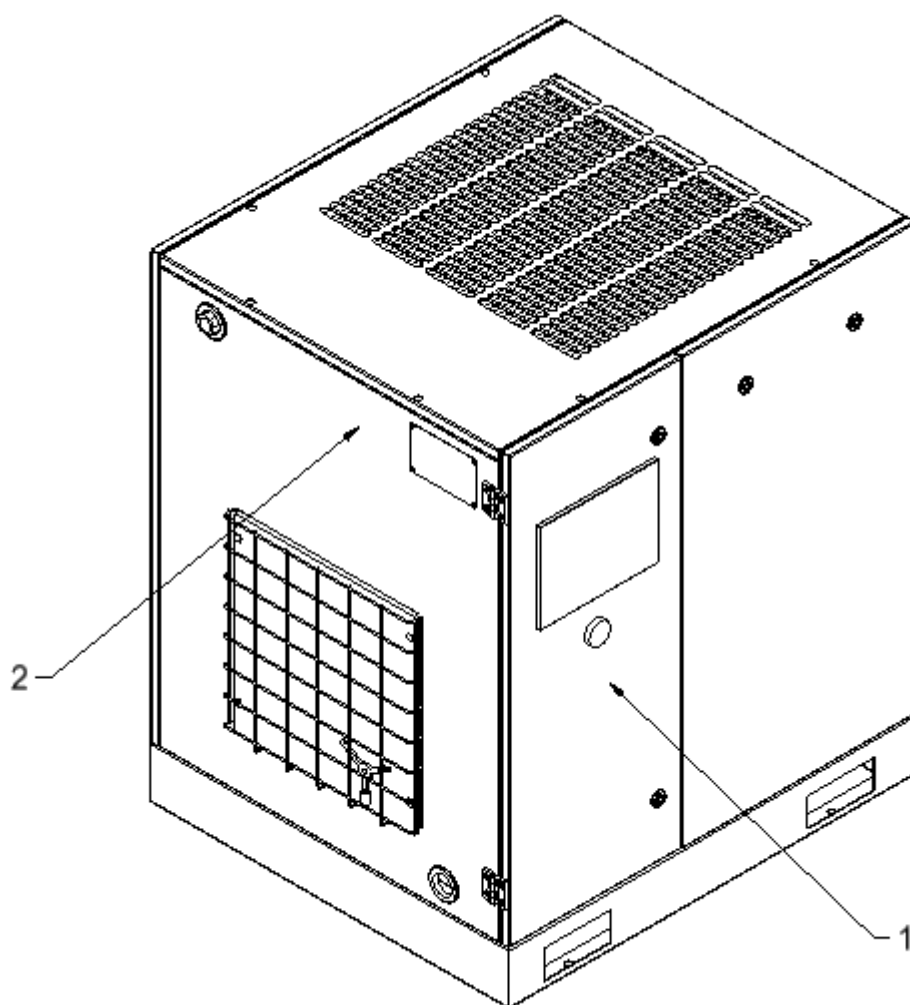
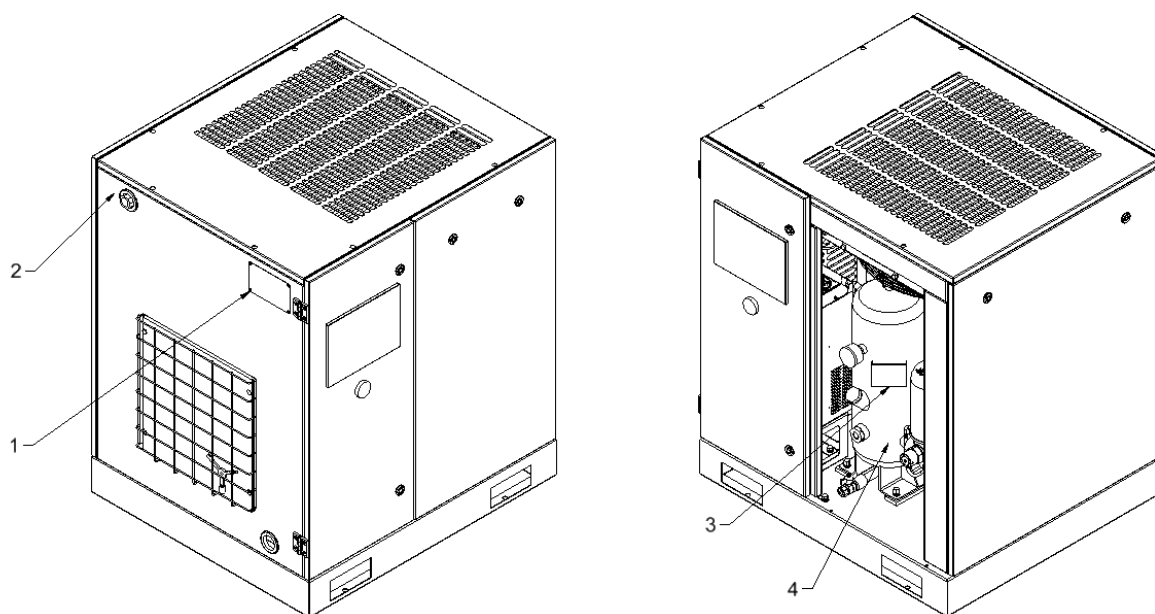

FIG.4

8.2 POSITION OF THE DATA PLATES

| | |
|---------------------|------------------------------|
| 1) Plate of machine | 2) Air not fit for breathing |
| 3) Vessel plate | 4) Vessel |

**FIG.5**

9.0 COMPRESSOR ROOM

9.1 FLOOR

The floor must be even and of industrial type; the total weight of the machine is about Kg. (See Ch. 13.0). Remember the total weight of the machine when positioning it.

9.2 VENTILATION

When the machine is operating, the room temperature must not be higher than **40 °C** or lower than **1 °C**.

The volume of the room must be about **30 m³**

The room must be provided with 2 openings for ventilation with a surface area of about **0.3 m²** each.

The first opening must be in a high position to evacuate the hot air, the second opening must be low to allow the intake of external air for ventilation.

If the environment is dusty it is advisable to fit a filtering panel on this opening.

The hot air ejected by the compressor may be led outside with a pipe.

This pipe must have a minimum section of **0.5 m²** and it must not be longer than **2 m**.

For longer pipes an extra fan must be fitted.

9.3 EXAMPLES OF VENTILATION OF THE COMPRESSOR ROOM

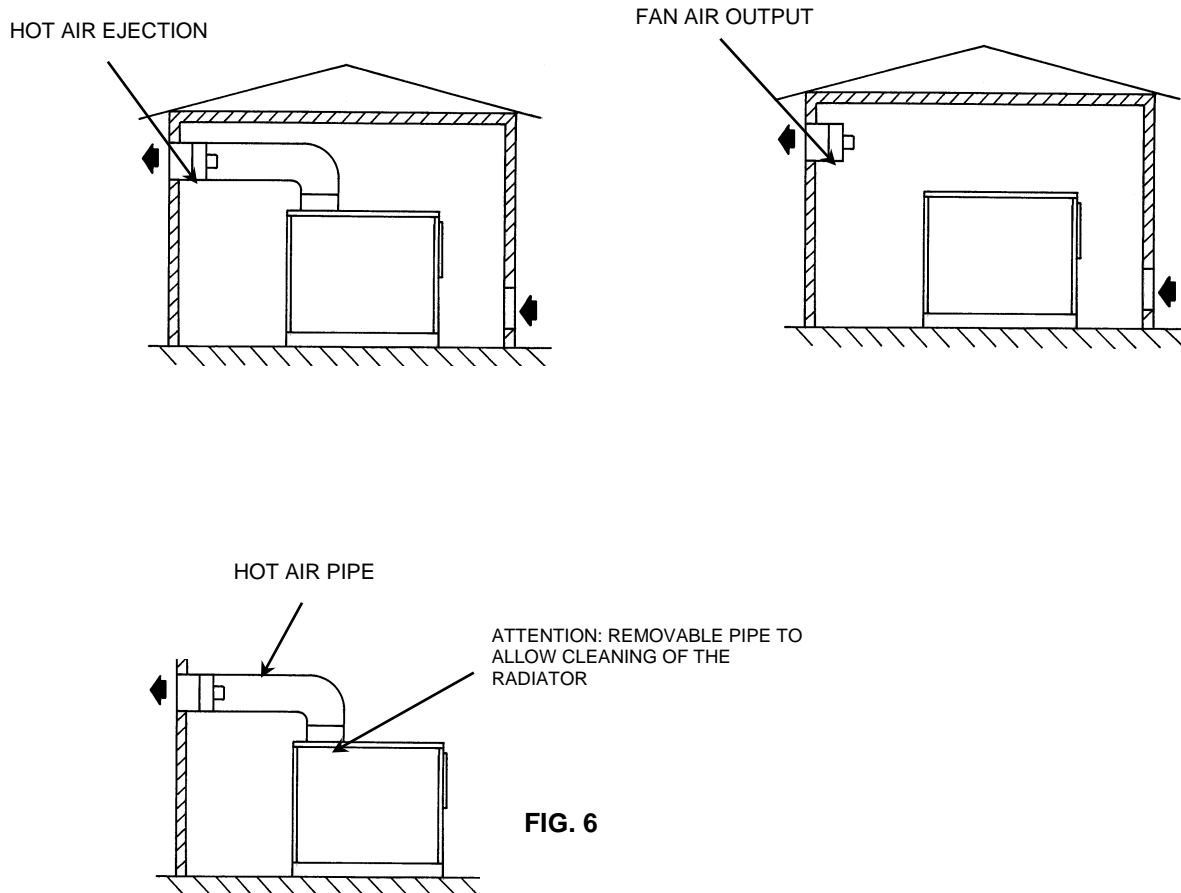

10.0 TRANSPORT AND HANDLING

ATTENTION: the machine must only be moved with the panels fitted (FIG. 7)

The machine must be transported as shown in the following figures.

DURING THE PROCEDURES THERE MUST NOT BE ANY PERSON, ANIMAL AND/THING WITHIN THE OPERATION AREA WHOSE SAFETY MAY BE ENDANGERED.

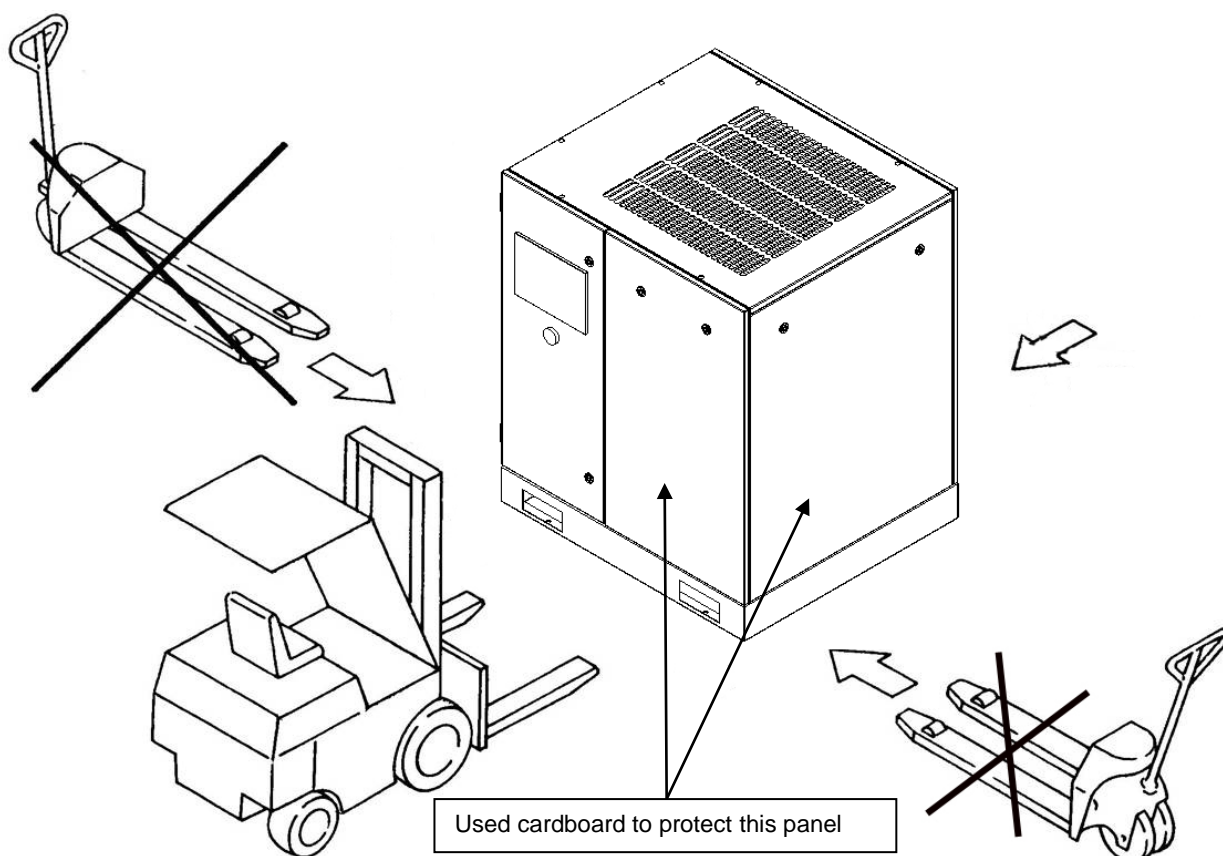

FIG. 7

11.0 UNPACKING

After removing the packing, ensure that the machine is unbroken and that there are no visibly damaged parts. If you are in doubt, do not use the machine but apply to the manufacturer technical assistance service or to your dealer. The packing material (plastic bags, polystyrene foam, nails, screws, wood, metal strapping, etc.) must not be left within the reach of children or abandoned in the environment, as they are a potential source of danger and pollution. Dispose of these materials in the approved collection centres. Remove transport support(red)

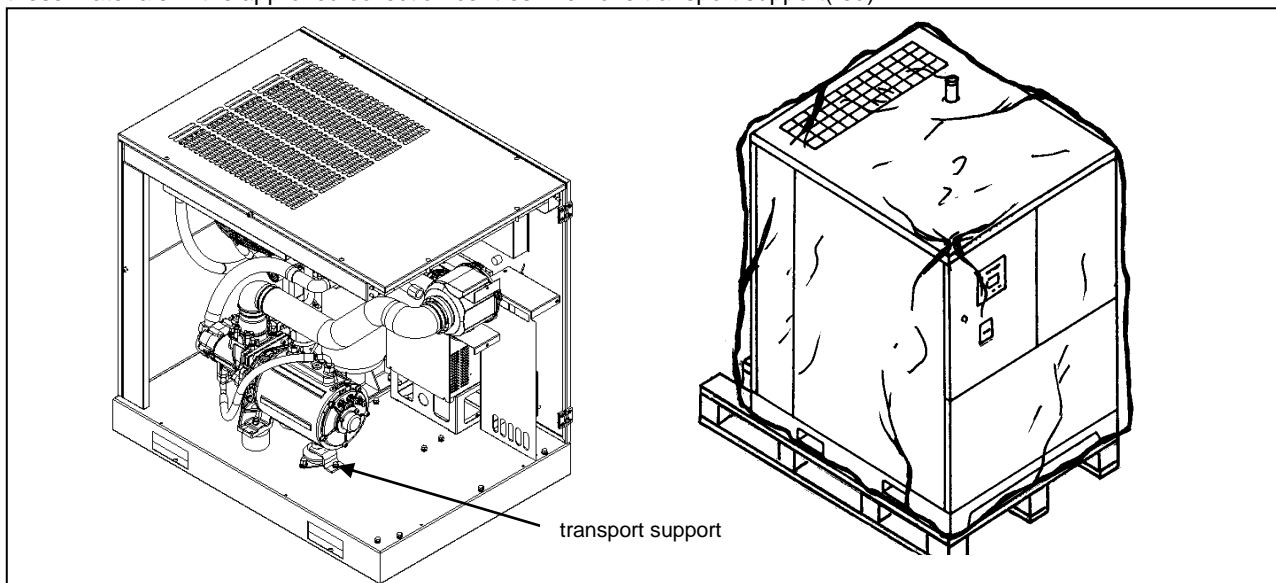

FIG. 8

FIG. 9

12.0 INSTALLATION

12.1 POSITIONING

After unpacking the equipment and preparing the compressor room, put the machine into position, checking the following items:

- ensure that there is sufficient space around the machine to allow maintenance (see FIG. 10).
- check the compressor is standing on a perfectly flat floor.

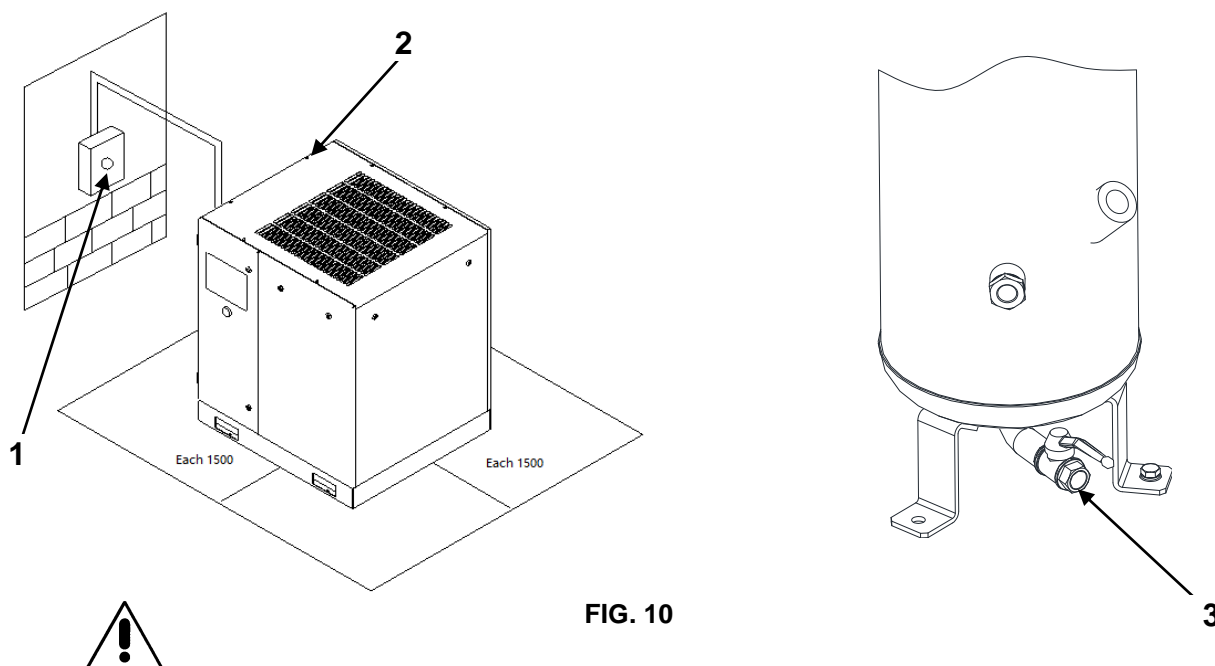

FIG. 10

3

ENSURE THAT THE OPERATOR CAN SEE THE WHOLE MACHINE FROM THE CONTROL PANEL AND CHECK THE PRESENCE OF ANY UNAUTHORIZED PERSONS IN THE VICINITY OF THE MACHINE.

12.2 ELECTRICAL CONNECTION



MACHINE WITH AUTOMATIC START

- Check that the supply voltage is the same as the value indicated on the machine data plate.
- Check the condition of the line leads and ensure that there is an efficient earth lead.
- Ensure that there is a main supply switch upstream for the machine (see Ref. 1 FIG. 10).
- Connect the machine power cables with the greatest care, according to the standards in force. These cables must be as indicated on the machine wiring diagram.
- After the first 50 working hours, check that the screws on the electric terminals are tight.



ONLY PROFESSIONALLY SKILLED PERSONNEL MAY HAVE ACCESS TO THE ELECTRIC PANEL. SWITCH OFF THE POWER BEFORE OPENING THE DOOR OF THE ELECTRIC PANEL.

COMPLIANCE WITH THE REGULATIONS IN FORCE CONCERNING ELECTRIC PLANTS IS FUNDAMENTAL FOR OPERATOR SAFETY AND FOR THE PROTECTION OF THE MACHINE

CABLES, PLUGS AND ALL OTHER TYPE OF ELECTRIC MATERIAL USED FOR THE CONNECTION MUST BE SUITABLE FOR THE USE AND COMPLYING WITH THE REQUIREMENTS STATED BY THE REGULATIONS IN FORCE.

12.3 CONNECTION TO THE COMPRESSED AIR NETWORK

Fit a manual interception valve Ref. 2 FIG. 10 between the machine and the compressed air network so that the compressor may be isolated during maintenance operations.

Condensate must be drained from the oil receiver (manually) Ref. 3 FIG. 10, in conformity with the local regulations in force.



PIPES, FITTINGS AND CONNECTIONS USED FOR THE CONNECTION OF THE ELECTROCOMPRESSOR TO THE COMPRESSED AIR NETWORK MUST BE SUITABLE TO THE USE ACCORDING TO THE PRESCRIPTIONS OF THE REGULATIONS IN FORCE IN THE COUNTRY OF USE.

ALL DAMAGE DUE TO THE FAILURE TO COMPLY WITH THESE INDICATIONS CANNOT BE ATTRIBUTED TO THE MANUFACTURER AND MAY CAUSE INVALIDITY OF THE GUARANTEE CONDITIONS.

12.4 STARTING UP

See part B of this manual, Chapter 20.0

13.1 S55 7.5-15kw PM

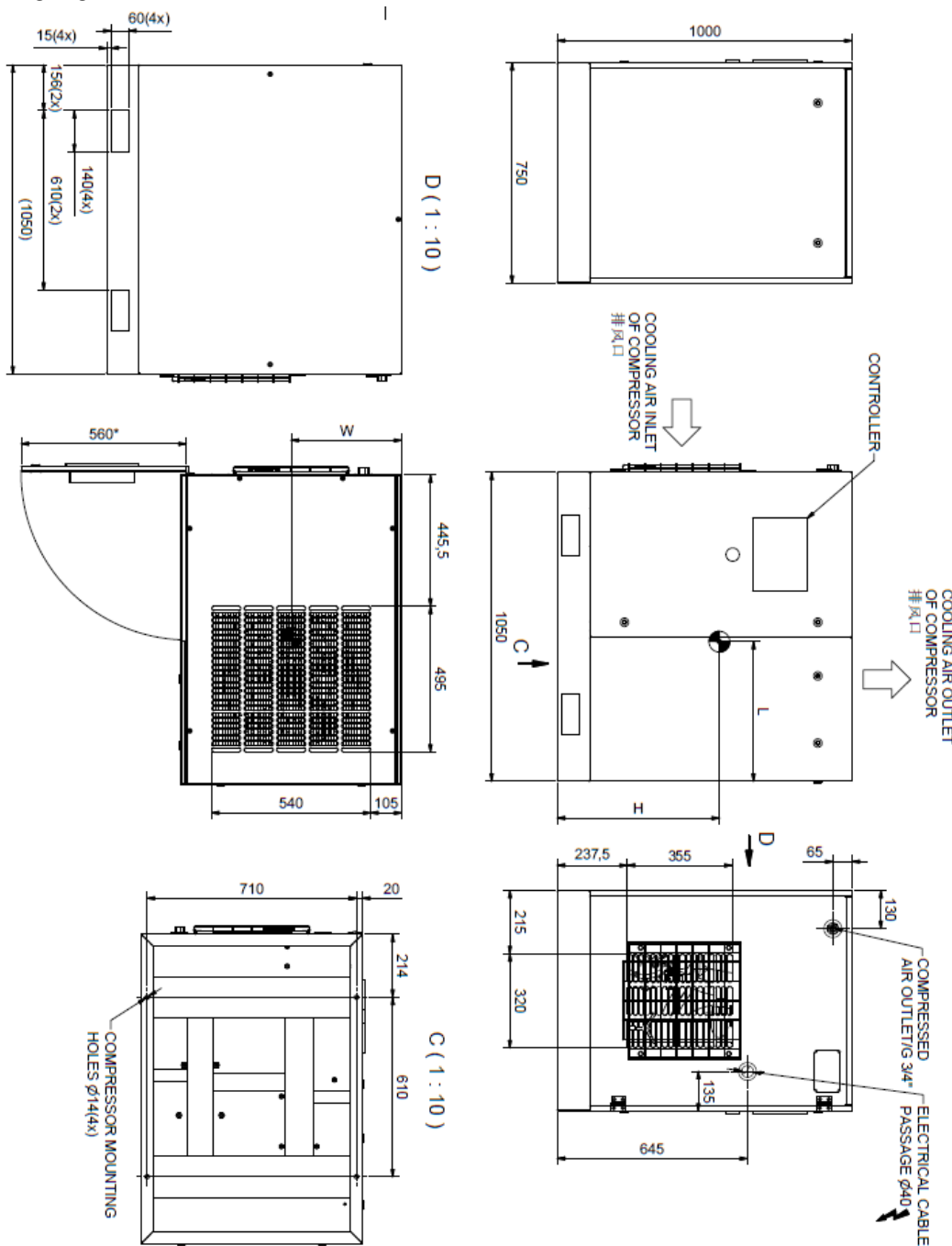

| Power kW | CSMV10 | CSMV15 | CSMV20 |
|-----------------------------|---------------|---------------|---------------|
| Pressure Mpa | MAX1.0 | MAX1.0 | MAX1.0 |
| Noise level dB(A) | 73 | 73 | 73 |
| Weight kg | 255 | 255 | 255 |
| Motor power kW | 7.5 | 11 | 15 |
| Fan motor power kW | 0.19 | 0.19 | 0.19 |
| Oil load (L) | ~5.5 | ~5.5 | ~5.5 |
| Outlet Size (G/DN) | G3/4" | G3/4" | G3/4" |
| Ventilation quantity (m3/h) | ≥3900 | ≥3900 | ≥5000 |
| Dimension (L x W x H mm) | 1050x750x1000 | 1050x750x1000 | 1050x750x1000 |

13.2 S67 18.5-22kw PM

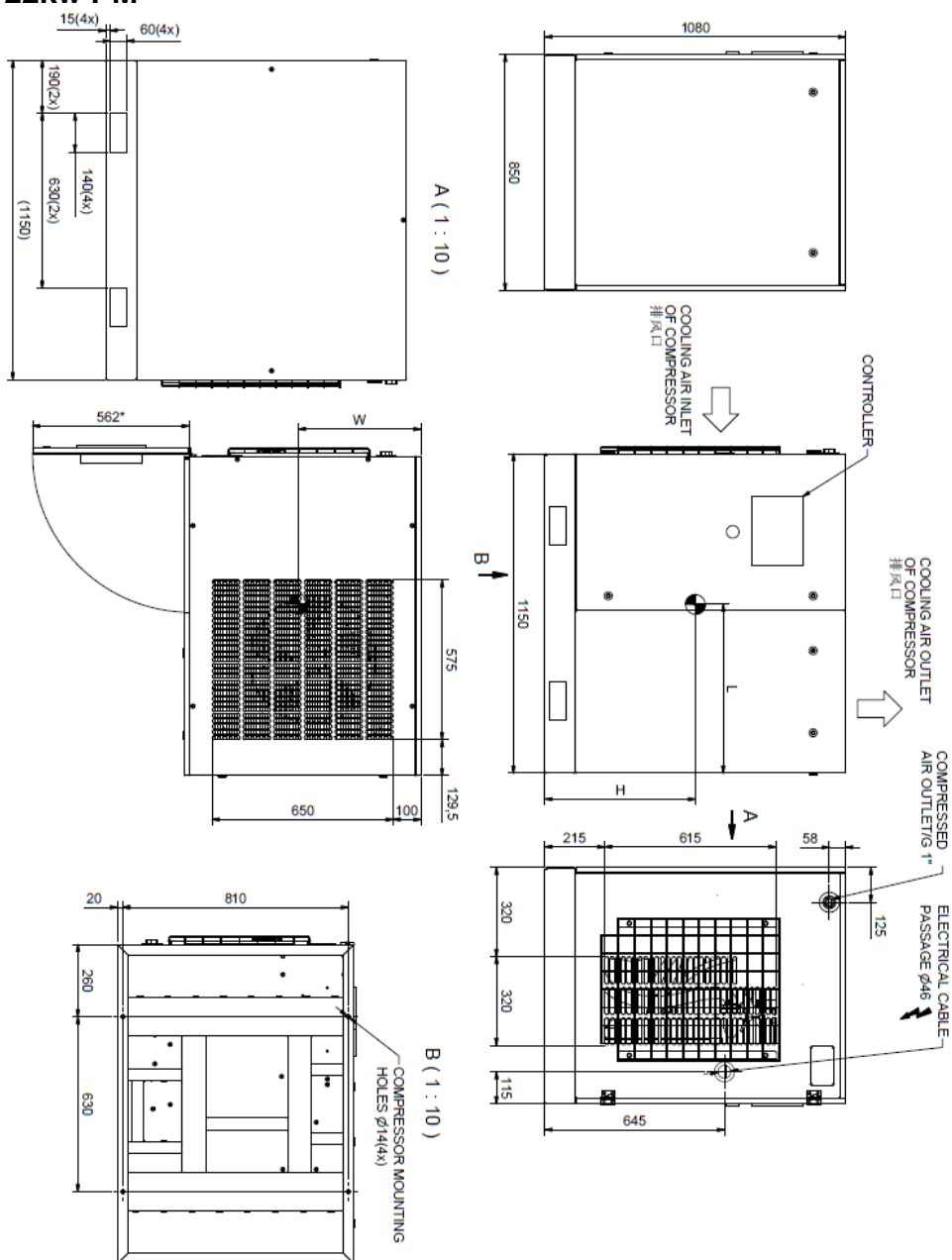

| Power kW | CSMV25 | CSMV30 |
|-----------------------------|---------------|---------------|
| Pressure Mpa | MAX1.0 | MAX1.0 |
| Noise level dB(A) | 73 | 73 |
| Weight kg | 330 | 340 |
| Motor power kW | 18.5 | 22 |
| Fan motor power kW | 0.25 | 0.25 |
| Oil load (L) | ~8.5 | ~8.5 |
| Outlet Size (G/DN) | G1" | G1" |
| Ventilation quantity (m3/h) | ≥5000 | ≥5000 |
| Dimension (L x W x H mm) | 1150x850x1080 | 1150x850x1080 |

13.2 S80/S90 30-37kw PM

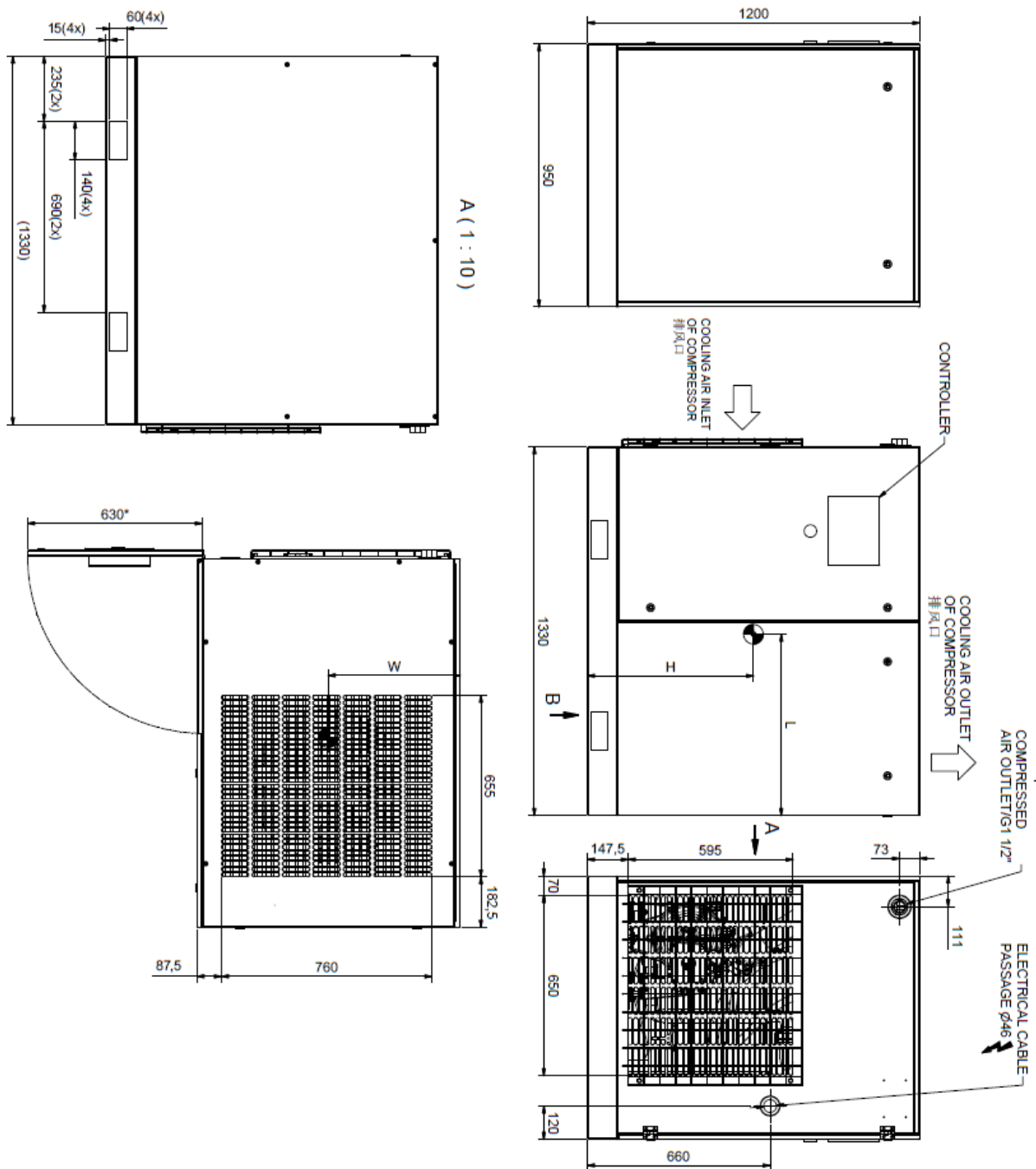

| Power kW | CPMV40 | CPMV50 |
|-----------------------------|---------------|---------------|
| Pressure Mpa | MAX1.0 | MAX1.0 |
| Noise level dB(A) | 75.9 | 76.8 |
| Weight kg | 410 | 466 |
| Motor power kW | 30 | 37 |
| Fan motor power kW | 0.6 | 0.6 |
| Oil load (L) | ~17 | ~17 |
| Outlet Size (G/DN) | G1 1/2" | G1 1/2" |
| Ventilation quantity (m3/h) | ≥5000 | ≥5000 |
| Dimension (L x W x H mm) | 1330x950x1200 | 1330x950x1200 |

14.0 MACHINE ILLUSTRATION

14.1 GENERAL LAY-OUT

| | |
|----------------------------|--|
| 1 Emergency stop | 12 Vessel |
| 2 Controller | 13 Oil outlet valve |
| 3 Air suction filter | 14 Safety valve(Change the relief valve set point is prohibited) |
| 4 Oil filter | 15 Motor |
| 5 Minimum pressure valve | 16 Element |
| 6 Cooler | 17 Cooling fan |
| 7 Thermostat valve | 18 unloader valve |
| 8 Vessel Pressure gauge | 19 Pre-filter |
| 9 Oil separator | 20 Converter |
| 10 Oil filling cap | 21 EMC filter |
| 11 Oil level sight glasses | 22 Terminal board |

. IT IS FORBIDDEN TO TAMPER WITH THE SETTING VALUES OF THE SAFETY VALVE

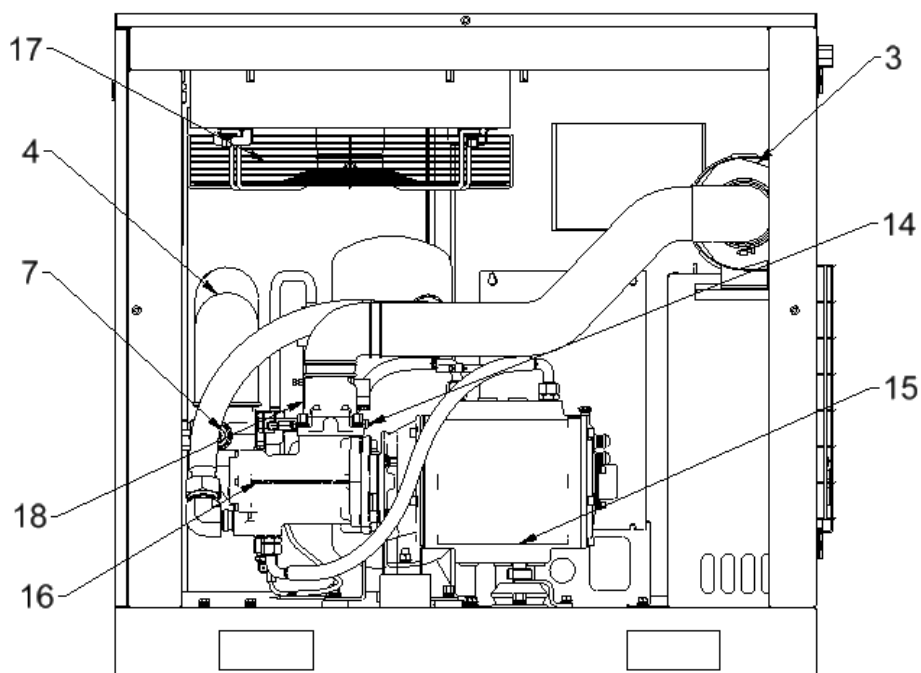
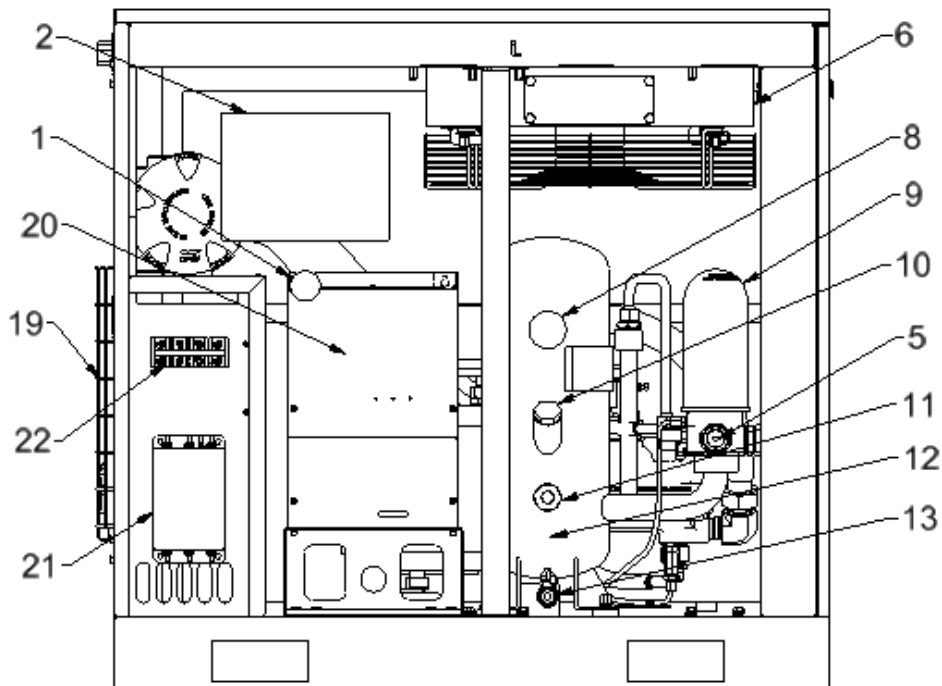

15.0 ORDINARY MAINTENANCE TO BE DONE BY THE USER



BEFORE CARRYING OUT ANY MAINTENANCE JOBS IT IS OBLIGATORY TO STOP THE MACHINE AND DISCONNECT IT FROM THE POWER MAINS.

The maintenance jobs described in this chapter may be carried out by the user. The more complex maintenance jobs which require professionally skilled personnel are listed in the chapter on **GENERAL ROUTINE MAINTENANCE. (See Chap. 21.0)**

15.1 GENERAL INFORMATION

Routine maintenance must be carried out according to the maintenance schedule affixed to the machine.

15.2 MAINTENANCE SCHEDULE

■ OPERATIONS THAT MAY BE CARRIED OUT BY THE USER

■ ■ OPERATIONS THAT REQUIRE SKILLED PERSONNEL; THESE OPERATIONS ARE ILLUSTRATED IN PART "B" OF THIS MANUAL.

These maintenance intervals are recommended for work environments that are not dusty and are well ventilated. For particularly dusty environments, double the frequency of controls. Change the air filter and the oil filter after the first 500 working hours.

| | | |
|---------------------------|-----|---|
| Every 50 working hours | ■ | Drain condensate from the oil collector |
| | ■ | Check the oil level |
| | ■ | Clean the filtering panel |
| Every 500 working hours | ■ | Clean the air suction filter |
| | ■ | Clean the finned surface of the air-oil cooler |
| | ■ | Retighten all power cable connections |
| Every 2000 working hours | ■ ■ | Change the oil filter |
| | ■ ■ | Change the air filter element |
| Every 4000 working hours | ■ ■ | All maintenance contents of 2000HRS |
| | ■ ■ | Change the oil separation element |
| | ■ ■ | Change the compressor oil |
| | ■ ■ | Test safety valve (or one year on first come basis) |
| | ■ ■ | Test temperature and emergency stop function |
| Every 8000 working hours | ■ ■ | Clean cooler |
| | ■ ■ | All maintenance contents of 4000HRS |
| | ■ ■ | Change the unloader service kit |
| | ■ ■ | Change MPV service kit |
| | ■ ■ | Change thermostatics valve element |
| Every 20000 working hours | ■ ■ | Change oil stop valve kit |
| | ■ ■ | All maintenance contents of 4000HRS |
| | ■ ■ | Change NDS bearing and wave spring of motor |
| | ■ ■ | Element or gear box overhaul and inspection |



BEFORE CARRYING OUT ANY MAINTENANCE JOBS IT IS OBLIGATORY TO STOP THE MACHINE AND DISCONNECT IT FROM THE POWER MAINS.

THE MAINTENANCE INTERVENTIONS ON THE ELECTROCOMPRESSOR CAN BE PERFORMED EXCLUSIVELY BY QUALIFIED MECHANICAL MAINTENANCE TECHNICAL ENGINEERS AND/OR BY SPECIALISED TECHNICAL PERSONNEL AUTHORISED BY THE MANUFACTURER.

15.3 DRAINING CONDENSATE FROM THE OIL COLLECTOR

If the compressor work cycle contemplates long pauses during which the machine cools down, a certain amount of condensate will gather in the oil collector. This happens, for example, when stopping overnight or at weekends. The condensate must be drained off every 50 hours or every week. This operation may be performed only when the machine is cold, that is when it has been switched off for at least 8 hours.



BEFORE DRAINING THE CONDENSATE IT IS OBLIGATORY TO STOP THE MACHINE AND DISCONNECT IT FROM THE POWER MAINS.

Proceed as follows:

- Press the "STOP" button Ref. 1 FIG. 13
- Press the "EMERGENCY STOP" button Ref. 2 FIG. 13.
- Turn off the main supply switch Ref. 1 FIG. 10

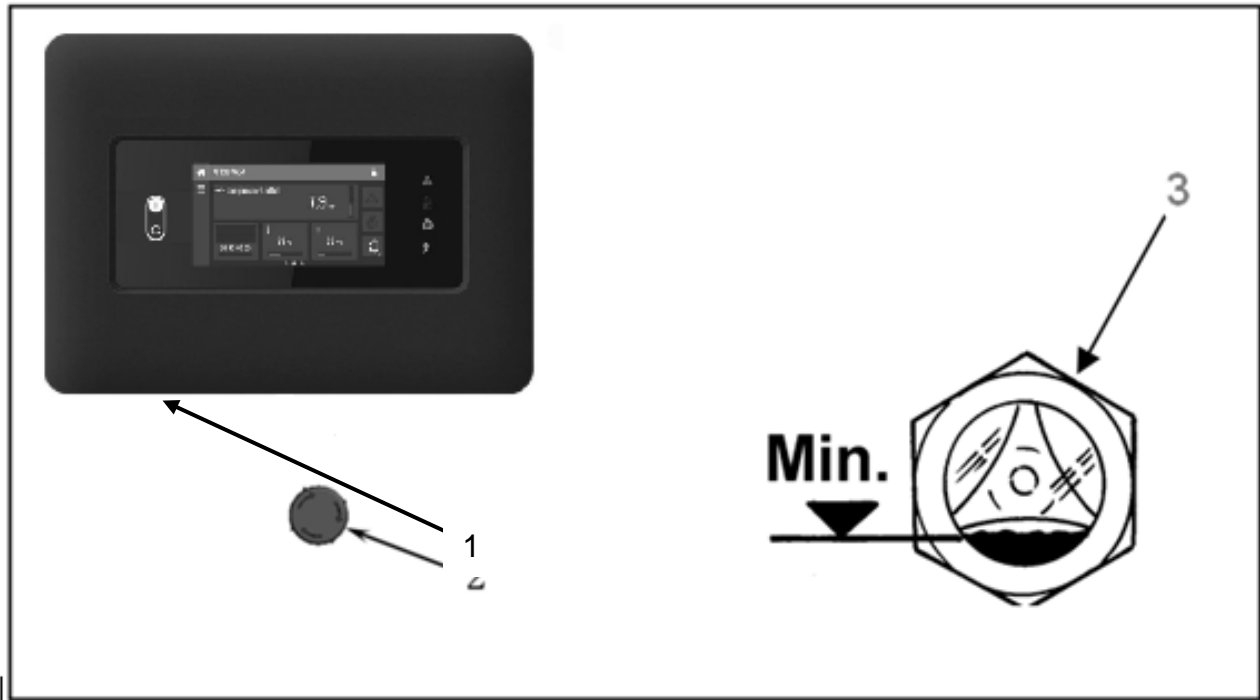

FIG.13

- Wait for the machine to cool down.
- Remove the side maintenance guard using the supplied key.
- SLOWLY turn on the tap Ref. 3 FIG. 10 and let the condensate flow out.
- When the first traces of oil appear, turn off the tap.



CONDENSATE MUST BE DISPOSED OF IN CONFORMITY WITH THE LOCAL REGULATIONS IN FORCE.

- Check the oil level on the indicator Ref. 3 FIG. 13
- If the oil level is under the minimum, top up as described at point 15.4

15.4 CHECK OIL LEVEL AND TOP UP

- Check oil level after machine switched off for about 30 minutes .
- Remove the side maintenance guard using the supplied key.
- Check the oil level on the indicator Ref. 3 FIG. 13
- If the oil level is under the minimum, top up.



USE OIL OF THE SAME TYPE AS THAT ALREADY IN THE MACHINE; DO NOT MIX DIFFERENT TYPES OF OIL

BEFORE CARRYING OUT ANY OPERATION ON THE MACHINE, ENSURE THAT THE ELECTRIC POWER SUPPLY HAS BEEN DISCONNECTED.

- Slowly open the oil plug Ref. 10 FIG. 11.
- Top up to maximum level Ref. 3 FIG. 13, with oil of the same type in the compressor.
- Turn off the cap of the oil tank.
- Close the side maintenance guard using the supplied key.

15.5 CLEANING THE FILTERING PANEL

- Press the "STOP" button Ref. 1 FIG. 13
- Press the "EMERGENCY STOP" button Ref. 2 FIG. 13
- Turn off the main supply switch Ref. 1 FIG. 10
- Remove the filter panel Ref. 1 FIG. 14
- Clean the filtering panel with a jet of air wash it with water, **do not use solvents.**
- Once the operation has been completed, reassemble the filter panel.

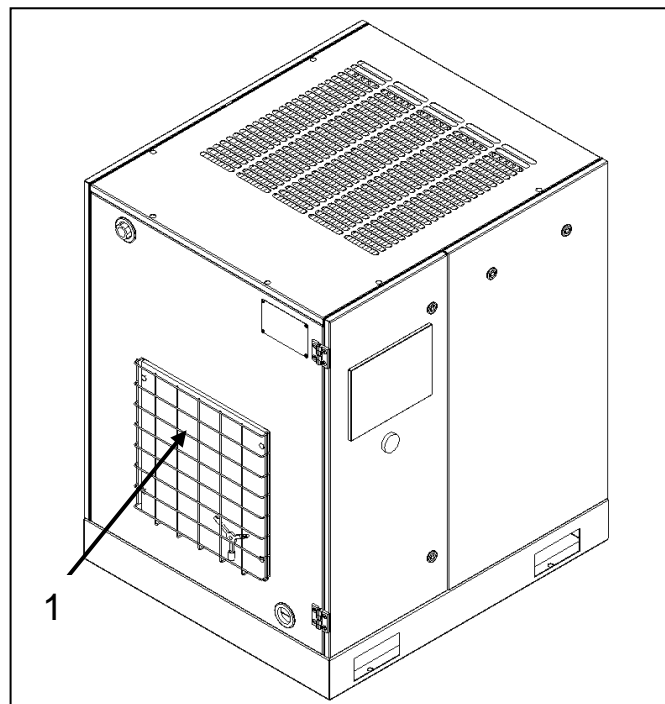

Air Cooling

FIG.14

15.6 CLEANING THE SUCTION FILTER OR CHANGING THE FILTER

- Press the "STOP" button Ref. 1 FIG. 13
- Press the "EMERGENCY STOP" button Ref. 2 FIG. 13
- Turn off the main supply switch Ref. 1 FIG. 10



HOT PARTS INSIDE.

- Remove the side maintenance guard using the supplied key.
- Remove the cover Ref. 1 FIG. 15.
- Remove the filter Ref. 2 FIG. 15.

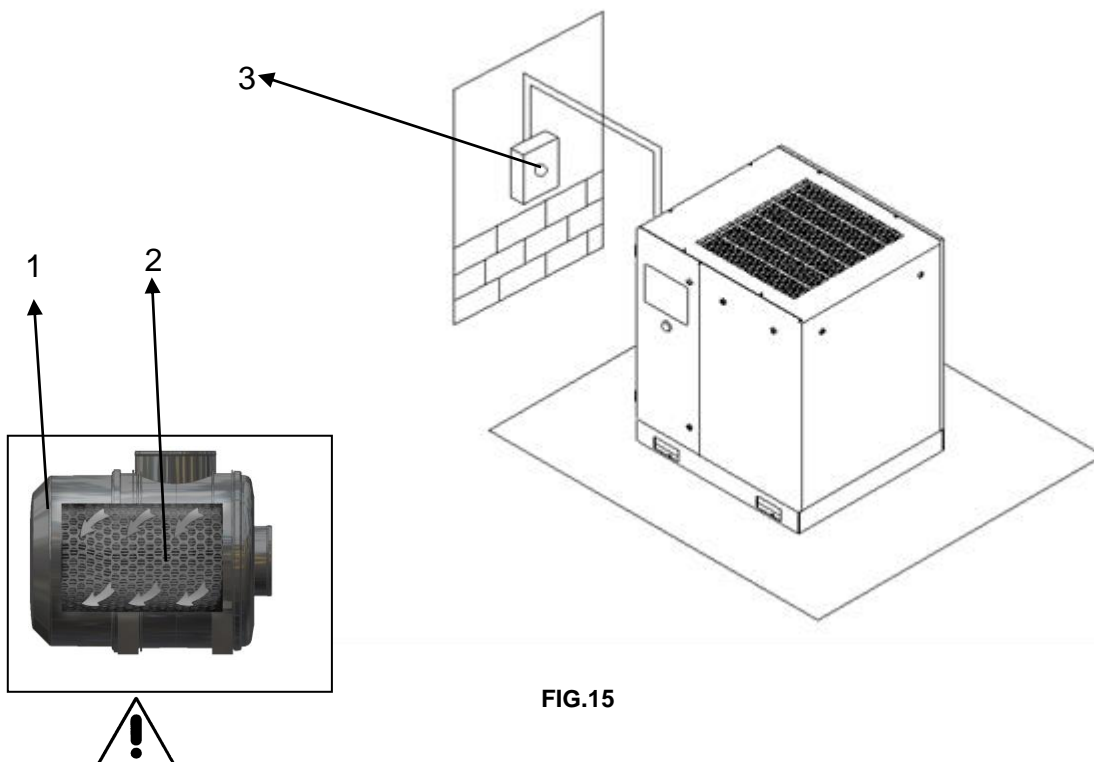

FIG.15

AVOID DROPPING FOREIGN BODIES INTO THE SUCTION MANIFOLD.

- Clean the filter with a jet of air, working from inside to outside.
- **DO NOT USE WATER OR SOLVENTS.** Alternatively, fit a new filter.
- Clean the disk on which the filter rests with a clean cloth.
- Fit the filter and the cover.
- If necessary, dispose of the old filter in conformity with the local regulations in force.
- Reclose the side maintenance guard using the supplied key.

16.0 PERIODS OF INACTIVITY

If the machine has to remain inactive for a long period:

- Press the "STOP" button Ref. 1 FIG. 13.
- Turn off the main supply switch Ref. 1 FIG. 10.
- Turn off the tap Ref. 2 FIG. 10.

During periods of inactivity the weather must be protected against atmospheric agents, dust and humidity which could damage the motor and the electrical system.

To restart the machine after periods of inactivity, consult the manufacturer.

17.0 SCRAPPING THE UNIT

If the machine is to be scrapped, it must be dismantled into parts of the same material, to be disposed of according to the local regulations in force.



THE LUBRICATING LIQUIDS AND OTHER EVENTUAL FLUIDS MUST NOT BE DISCHARGED IN THE ENVIRONMENT. THESE POLLUTING AND HAZARDOUS PRODUCTS MUST COMPULSORY BE DISPOSED BY CHARGING AUTHORISED AND SPECIALISED FIRMS ACCORDING TO THE DIFFERENT TYPOLOGY OF PRODUCT.

ALWAYS RESPECT THE REGULATIONS IN FORCE FOR DISPOSING OF OLD OIL AND OTHER POLLUTING MATERIALS SUCH AS SOUND-DEADENING, FOAM, ETC.

18.0 LIST OF SPARE PARTS FOR ROUTINE MAINTENANCE

| No | code | name | Qty | For |
|----|--------------|---------------------------|-----|--|
| 1 | 1625 1853 78 | Pre- filter | 1 | CSMV10 ,CSMV15 ,CSMV20 |
| 1 | 1625 1854 40 | Pre- filter | 1 | CSMV25 ,CSMV30 |
| 1 | 1641 0002 64 | Pre- filter | 1 | CSMV40 ,CSMV50 |
| 2 | 6211 4723 50 | Air inlett Filter element | 1 | CSMV10 ,CSMV15 ,CSMV20 |
| 2 | 6211 4723 50 | Air inlett Filter element | 1 | CSMV25 ,CSMV30 |
| 2 | 1625 1736 72 | Air filter core | 1 | CSMV40 ,CSMV50 |
| 3 | 1641 0001 36 | Oil filter | 1 | CSMV10 ,CSMV15 |
| 3 | 1641 0001 37 | Oil filter | 1 | CSMV20, CSMV25 ,CSMV30 CSMV40 ,CSMV50 |
| 4 | 1641 0001 38 | Oil separator | 1 | CSMV10 ,CSMV15 ,CSMV20 |
| 4 | 1641 0001 39 | Oil separator | 1 | CSMV25 ,CSMV30 |
| 4 | 1641 0001 45 | Oil separator | 1 | CSMV40 ,CSMV50 |

Oil-Fluidtech

5L——1630 1444 05

20L——1630 1444 20

209L——1630 1444 29

FOR MORE DETAILS OF SPARE PARTS, PLEASE REFER TO THE SPARE PARTS BOOK

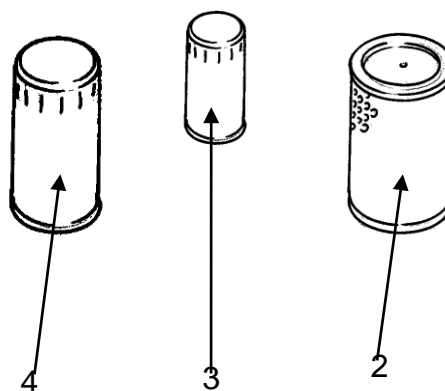
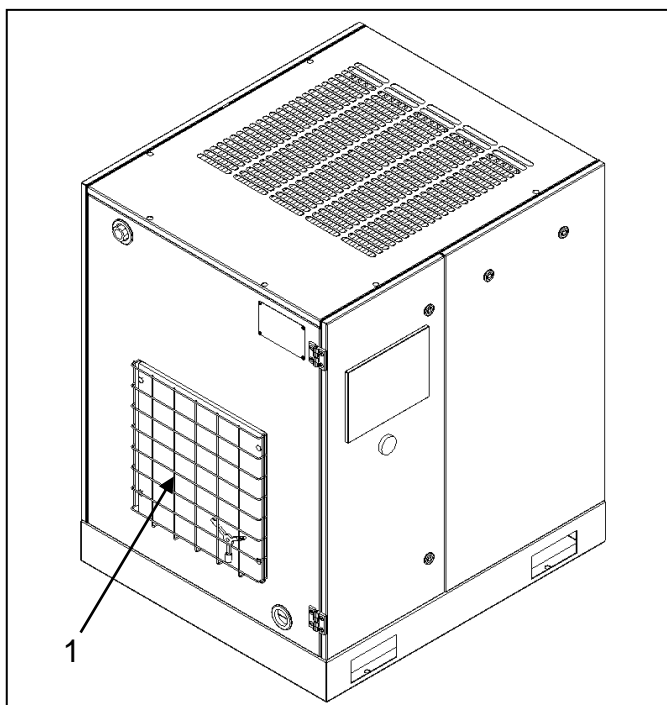

19.0 TROUBLE-SHOOTING AND EMERGENCY REMEDIES



ALL WORK MUST BE CARRIED OUT BY PROFESSIONALLY SKILLED PERSONNEL. BEFORE CARRYING OUT ANY MAINTENANCE JOBS IT IS OBLIGATORY TO STOP THE MACHINE AND DISCONNECT IT FROM THE POWER MAINS.

N.B. OPERATIONS MARKED ■ ■ MUST BE CARRIED OUT BY PROFESSIONALLY SKILLED PERSONNEL APPROVED THE MANUFACTURER.

| FAULT FOUND | POSSIBLE CAUSES | OBSERVATIONS |
|---|---|---|
| 1) The machine does not start | <p>1A - no power</p> <p>1B - the transformer protection device has tripped</p> <p>1C - the main motor protection device has tripped</p> <p>1D - the oil high temperature thermostat has tripped</p> <p>1E - The fan motor thermal protection has triggered</p> <p>1F - Inverter fault</p> | <p>- Check the power supply line, Chapter 12.2</p> <p>- Replace fuses</p> <p>- Reset the automatic switch that protects the fan</p> <p>- Environment temperature too high; improve ventilation in the compressor room, Chapter 9.2</p> <p>■ ■ - cooling radiator is dirty, clean the radiator</p> <p>- oil level too low; top up the oil tank</p> <p>- Rearm the fan motor thermal protection.</p> <p>- Check the electric system</p> |
| 2) The compressor does not reach working pressure | <p>2A - the compressed air consumption is too high</p> <p>2B - the discharge electrovalve remains open, Ref. EV/SC wiring diagram</p> <p>2C - OSE blocking</p> <p>2D - Air filter blocking</p> | <p>■ ■ - Check the electric system</p> <p>- Check or change the OSE</p> <p>- Clean or change the air filter</p> |
| 3) Excess oil consumption | <p>3A - Deteriorated oil separating filter oil level is too high</p> <p>3B - The return pipe choke blocking</p> <p>3C - Ose or gasket damaged</p> | <p>■ ■ - Change the oil separating filter, Chapter 23</p> <p>- Clean or change the return pipe choke</p> <p>- Check the ose or gasket</p> |
| 4) High outlet temperature | <p>4A - Ambient temperature is too high</p> <p>4B - Thermostatic valve failure</p> <p>4C - Oil quantity few</p> <p>4D - Failure of temperature sensor</p> <p>4E - Failure of fan</p> <p>4F - The fins of the oil cooler are dirty</p> | <p>- Improve ambient ventilation</p> <p>- Check or change thermostatic valve</p> <p>- Check and change oil level</p> <p>- Check and change temperature sensor</p> <p>- Check and change fan</p> <p>- Clean the fins of the oil cooler</p> |

PART “B”



**THIS PART B OF THE INSTRUCTIONS MANUAL IS RESERVED
FOR PROFESSIONALLY SKILLED PERSONNEL APPROVED THE
MANUFACTURER.**

20.0 STARTING UP

MACHINE WITH AUTOMATIC START.



BEFORE CARRYING OUT ANY OPERATION ON THE MACHINE, ENSURE THAT THE ELECTRIC POWER SUPPLY HAS BEEN DISCONNECTED.

20.1 PREPARING FOR SETTING UP

After checking everything as indicated in Chap. 12, follow the instructions in FIG. 16.

- Check the oil level Ref. 1 FIG. 16A when supplied the machine is filled with oil; if the oil is not at the correct level, top up with the same oil as the original type.

If more than 3 months have passed between the inspection in the factory and the date of installation, lubricate the screw group before starting up, following the procedure described below:

- Remove the cover Ref. 2 Fig. 15
- Remove the air filter Ref. 1 Fig. 15
- Pour a little oil into the suction unit.
- Reassemble the air filter.
- Reassemble the cover.

If more than 6 months have passed between the inspection in the factory and the date of installation, consult the manufacturer.

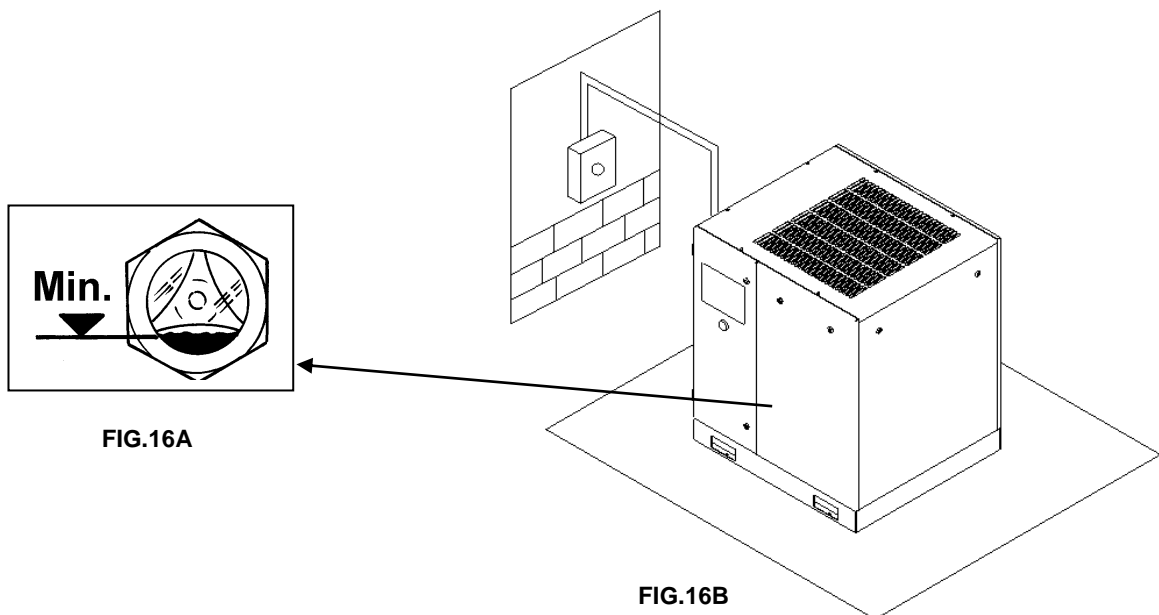

FIG.16A

FIG.16B

20.2 CHECK THE DIRECTION OF ROTATION

- Check that all fixed guards are in their correct position.
- Connect the control board to the power supply with the automatic circuit-breaker switch and the master switch of the machine.
- Start up the compressor pushing in sequence "I" button and immediately after about 1 second the "O" button Fig. 13 to stop if.



ALL WORK ON THE ELECTRIC PLANT, HOWEVER SLIGHT, MUST BE CARRIED OUT BY PROFESSIONALLY SKILLED PERSONNEL.

- If the rotation direction is not correct, turn off the power and reconfirm the join order.

IT IS ADVISABLE NOT TO DO ANYTHING ON THE MACHINE PANEL.

IF ALL THE INSTRUCTIONS FOUND IN THIS MANUAL HAVE BEEN OBSERVED THE MACHINE CAN BE STARTED.



ATTENTION: machine start-up is delayed for a few seconds from the moment the card is Powered or of the scheduled stop.

21.0 GENERAL ORDINARY MAINTENANCE REQUIRES TRAINED PERSONNEL

BEFORE CARRYING OUT ANY MAINTENANCE JOBS IT IS OBLIGATORY TO STOP THE MACHINE AND DISCONNECT IT FROM THE POWER MAINS.

MAINTENANCE SCHEDULE

These maintenance intervals are recommended for work environments that are not dusty and are well ventilated. For particularly dusty environments, double the frequency of controls.

Change the air filter and the oil filter after the first 500 working hours.

| | | |
|---------------------------|-----|---|
| Every 50 working hours | ■ | Drain condensate from the oil collector |
| | ■ | Check the oil level |
| | ■ | Clean the filtering panel |
| Every 500 working hours | ■ | Clean the air suction filter |
| | ■ | Clean the finned surface of the air-oil cooler |
| | ■ | Retighten all power cable connections |
| Every 2000 working hours | ■ ■ | Change the oil filter |
| | ■ ■ | Change the air filter element |
| Every 4000 working hours | ■ ■ | All maintenance contents of 2000HRS |
| | ■ ■ | Change the oil separation element |
| | ■ ■ | Change the compressor oil |
| | ■ ■ | Test safety valve (or one year on first come basis) |
| | ■ ■ | Test temperature and emergency stop function |
| Every 8000 working hours | ■ ■ | Clean cooler |
| | ■ ■ | All maintenance contents of 4000HRS |
| | ■ ■ | Change the unloader service kit |
| | ■ ■ | Change MPV service kit |
| | ■ ■ | Change thermostatics valve element |
| Every 20000 working hours | ■ ■ | Change oil stop valve kit |
| | ■ ■ | All maintenance contents of 4000HRS |
| | ■ ■ | Change NDS bearing and wave spring of motor |
| | ■ ■ | Element or gear box overhaul and inspection |

N.B.: THE OPERATIONS MARKED ■ ARE DESCRIBED IN PART "A" OF THIS MANUAL ON CHAPTER 15.2

22.0 CHANGING THE OIL



BEFORE CARRYING OUT ANY MAINTENANCE JOBS IT IS OBLIGATORY TO STOP THE MACHINE AND DISCONNECT IT FROM THE POWER MAINS AND FROM THE COMPRESSED AIR DISTRIBUTION NETWORK.

Oil changing is an important operation for the compressor:

if the lubrication of the bearings is not efficient, the compressor life will be short.

The oil must be changed when the machine is still warm, that is immediately after stopping it.

The suggestions listed below should be scrupulously followed.

After draining the old oil out of the machine Ref. 2 FIG. 17.

- Fill the oil tank to the MAX level, Ref. 1 FIG. 17.

- Pour a little oil into the suction unit.

- Start the compressor.

- After about 1 minute switch off the machine by pressing "STOP" (Ref. 1 FIG. 18) after a few seconds of idle running the machine will switch off.

PROCEED AS DESCRIBED AT POINT CHAPTER 15.4

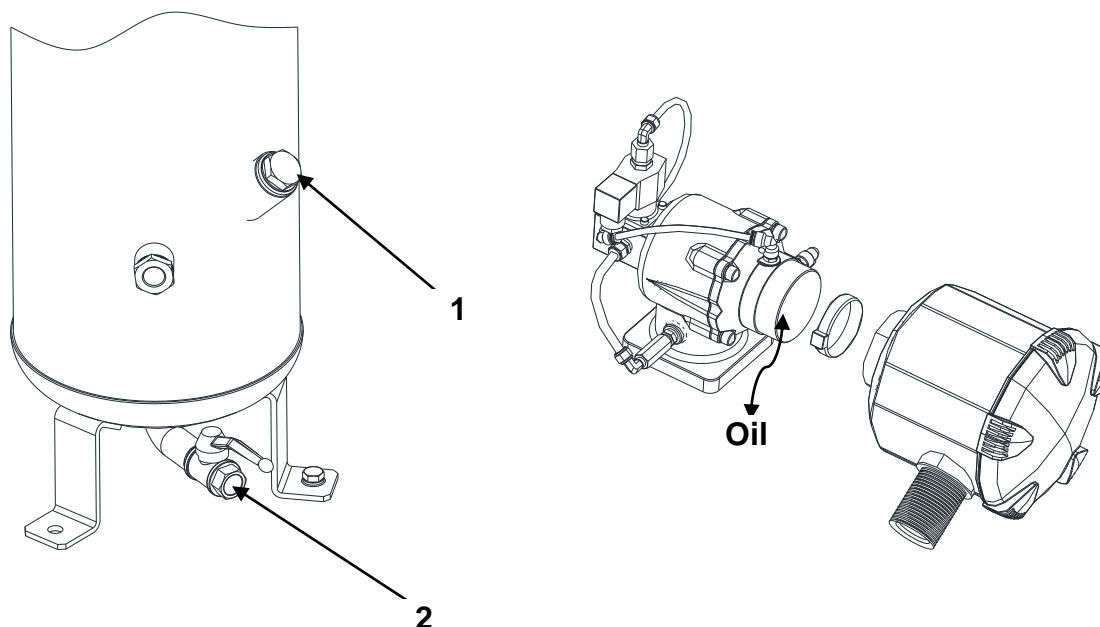

FIG. 17



**THE OLD OIL MUST BE DISPOSED OF IN COMPLIANCE WITH THE REGULATIONS IN FORCE.
DO NOT TOP UP WITH DIFFERENT OILS.**

NOTE ON LUBRICANTS

When delivered the machine is filled with oil;

In normal conditions of use, these lubricants have proved to be able to withstand use for as many as 2.500~4.000 hours. However, due to the external polluting agents that get into the compressor with the air that it takes in, it is advisable to change the oil at more frequent intervals, as indicated on the routine maintenance chart.

If the compressor is being used at high temperatures (continuous operation above 90 °C) or in particularly severe conditions, we advise changing the oil at shorter intervals than those recommended in the maintenance chart.

23.0 CHANGING THE OIL SEPARATING FILTER

BEFORE CARRYING OUT ANY MAINTENANCE THE MACHINE MUST BE STOPPED, CUT OFF THE MACHINE FROM THE ELECTRICAL MAINS AND FROM THE COMPRESSED AIR DISTRIBUTION CIRCUIT, CHECK THAT THE MACHINE IS NOT UNDER PRESSURE.

Proceed as follows:

- Press the "STOP" button Ref. 1 FIG. 18.
- Press the "EMERGENCY STOP" button Ref. 2 FIG. 18.
- Turn off the main supply switch Ref. 3 FIG. 18.
- Turn off the Outlet valve Ref. 4 FIG. 18.
- Check there is no pressure inside the machine: check the pressure gauge Ref. 5 FIG. 18.
- Change the oil-separating filter Ref. 6 FIG. 18.

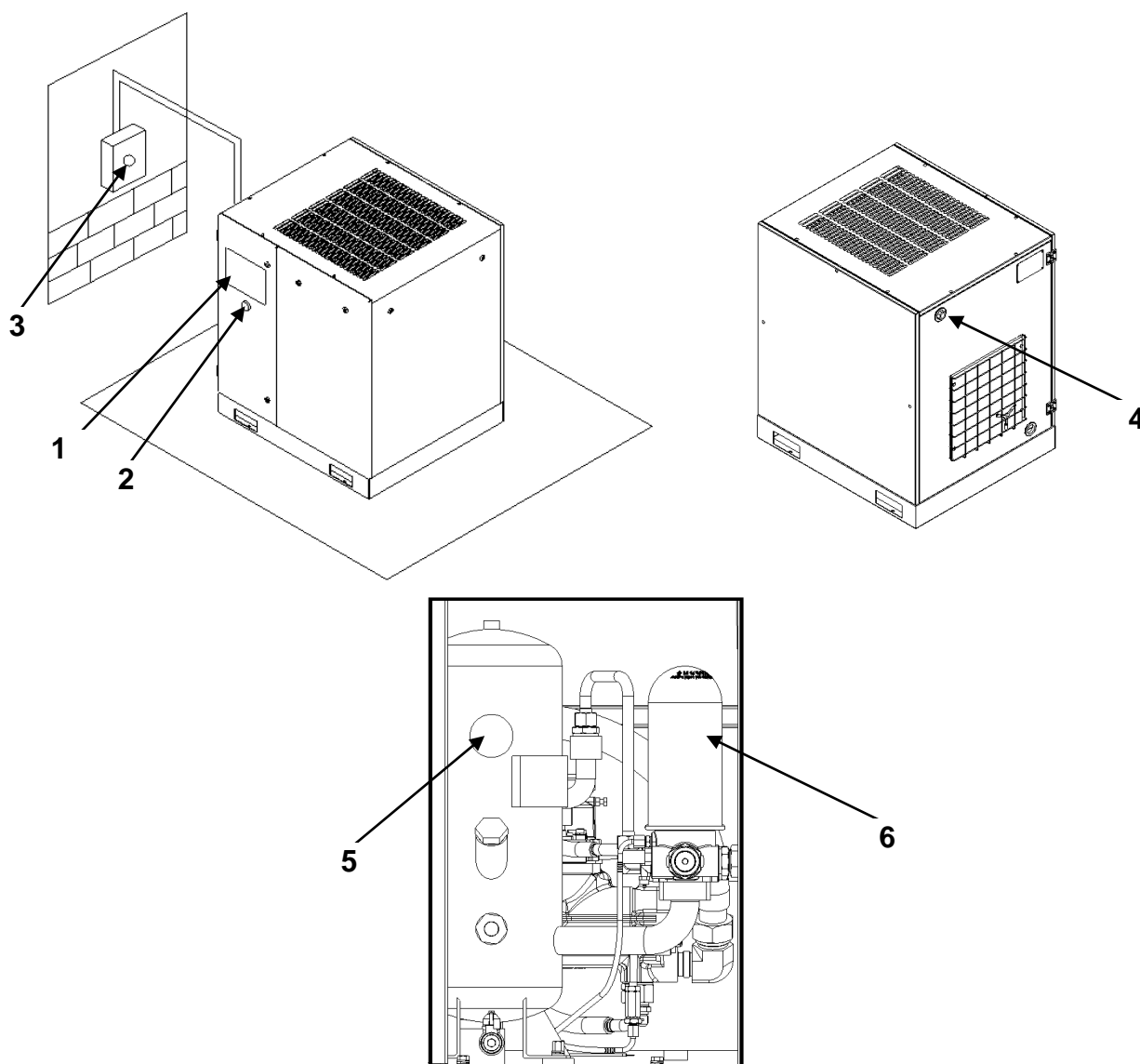

FIG. 18

24.0 SYSTEM DIAGRAM

