

Round cylinders CRDSNU

FESTO



Key features

At a glance

The stainless steel round cylinder CRDSNU in clean design is the perfect choice for the most demanding ambient conditions.

- Corrosion resistant against aggressive ambient conditions
- Easy-to-clean design
- Long service life thanks to optional dry-running seal
- Wide range of variants for customised applications
- Self-adjusting pneumatic end-position cushioning saves time during commissioning and adapts optimally to load and speed changes
- Suitable for direct contact with food according to European Regulation (EC) No. 1935/2004
More information → www.festo.com/certificates/crdsnu_pub
- FDA-compliant seal and NSF-H1 lubrication

Applications

Reliable components need to be fully functional and operational, even in harsh operating conditions. The aim is to maximise availability of machinery while minimising downtimes. Stainless-steel cylinders are therefore used in applications where the surface finish of normal pneumatic drives would not be able to withstand the surrounding media. However, designing a corrosion-resistant system involves more than simply selecting a suitable steel; it also requires the selection of a matching concept for mounting components and accessories.

Application example:

The atmosphere in the maturing cellar of a cheese factory consists of an unpleasant mix of ammonia, lactic acid and 98% humidity.

Strengths

The stainless-steel cylinders from Festo are characterised by resistant materials, such as 1.4301 and 1.4401. These popular high-alloy, stainless austenitic chrome-nickel and chrome-nickel-molybdenum steels protect against chemical or electrochemical stress as well as damage to the surface materials caused by cleaning agents or disinfectants. These groups of materials are particularly resistant to uniform surface corrosion and offer increased protection against pitting and crevice corrosion.

The benefits to you

The Festo worldwide service network ensures optimum availability of stainless-steel cylinders. As well as a comprehensive range of standards-based cylinders to DIN ISO 15552 and 6432, we also offer a range of matching mounting components and accessories. The stainless-steel cylinders are assembled with grease that is compliant with NSF-H1 and wipers in accordance with BGVV (Federal Institute for Risk Assessment) guidelines. This means that they are suitable for use in the food zone. We will be pleased to provide you with further information about future additions to our stainless-steel range. Just get in touch with us.

Good to know

For applications in harsh environments, you can rely on our years of experience in stainless steel. Our experts will answer any questions you might have about surface finishes and chemical resistance.

Key features

Resistance

Complete resistance to pitting and crevice corrosion is not always possible, even with ideal application parameters. The following parameters increase the pitting effect of chloride ions:

- Concentration of chloride ions
- Duration of contact
- Temperature
- Decreasing pH value

It must therefore be ensured during design, assembly and operation that all parts of the machinery can be properly cleaned to avoid an accumulation of chloride ions.

Selected sealing materials ensure very high resistance to a wide range of chemical compounds.

Further information on media resistance can be obtained on the Internet at www.festo.com.

In principle, we recommend that the cylinder be cleaned with the piston rod in the retracted position to avoid the risk of washing out the lifetime lubrication.

Various types of contamination of machines make cleaning processes necessary in many industry sectors.

The degree of cleaning required ranges from wiping the machinery with a dry cloth to wet cleaning to foam cleaning with different exposure times and concentrations.

It is therefore impossible to make a general recommendation on compatibility.



Wet cleaning



Foam cleaning

Key features

Variants

CRDSNU
Basic version

CRDSNU-S2:
Through piston rod

CRDSNU-MQ:
Short end cap without swivel
mounting

CRDSNU-MG/CRDSNU-B-MG:
Bearing cap without mounting
thread

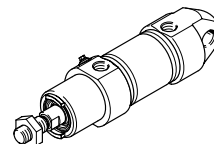
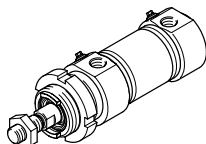
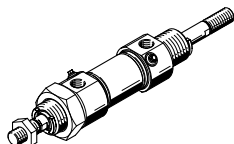
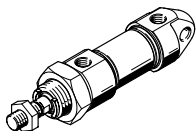

Further variants

Symbol	Key features	Description
	S2 Through piston rod	For working at both ends with the same force in the forward and return stroke, for attaching external stops
	S6 Heat-resistant seals	Temperature resistance up to max. 120 °C
	K2 Extended male piston rod thread	–
	K3 Female piston rod thread	–
	K5 Special piston rod thread	Metric standard thread to ISO
	K8 Extended piston rod	–
	A1 Wiper variant	Increased chemical resistance: Wiper made from fluoro rubber
	A2 Wiper variant	Hard wiper: Cylinder with hard scraper for dust, particles and viscous media
	A3 Wiper variant	Unlubricated operation: Cleaning processes degrease the piston rod. A special piston rod seal permits a longer service life compared to the standard seal.
	TT Low temperature	Temperature resistance down to max. –40 °C

Key features

Cushioning types			
	Cushioning P	Cushioning PPS	Cushioning PPV
Operating mode	<ul style="list-style-type: none"> The drive is fitted with polymer elastic end-position cushioning 	<ul style="list-style-type: none"> The drive is fitted with self-adjusting end-position cushioning 	<ul style="list-style-type: none"> The drive is fitted with adjustable end-position cushioning
Application	<ul style="list-style-type: none"> Small loads Low speeds Low impact energies 	<ul style="list-style-type: none"> Small to medium loads Low to medium speeds Medium impact energies 	<ul style="list-style-type: none"> Medium to large loads High speeds High impact energies
Advantages	<ul style="list-style-type: none"> No adjustment required Saves time 	<ul style="list-style-type: none"> No adjustment required Saves time Powerful 	<ul style="list-style-type: none"> Very powerful

Peripherals overview

CRDSNU-12 ... 25-...

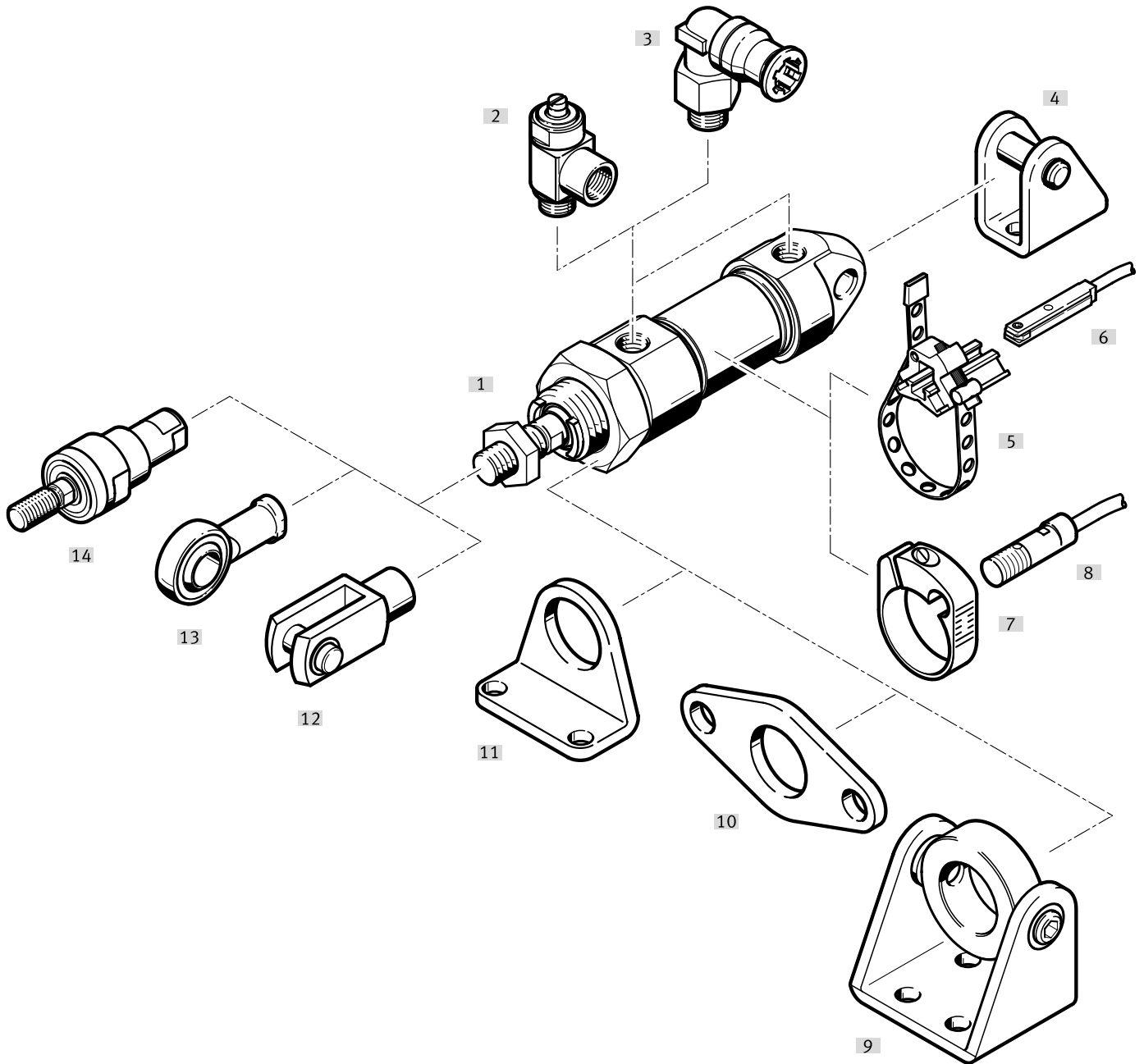

Peripherals overview

Mounting attachments and accessories		Description	CRDSNU-			CRDSNU-B	→ Page/ Internet
			Basic version	MQ	MG	MG	
[1]	Standards-based cylinder CRDSNU-12 ... 25-...						
[2]	One-way flow control valve CRGRLA	For regulating speed	■	■	■	■	43
[3]	Push-in fitting CRQS	For connecting tubing with standard O.D.	■	■	■	■	qs
[4]	Clevis foot CRLBN	For end caps	■	-	■	■	40
[5]	Mounting kit SMBR	For proximity switches CRSMT-8	■	■	■	■	43
[6]	Proximity switch CRSMT-8M	<ul style="list-style-type: none"> • Design for T-slot • For position sensing 	■	■	■	■	41
[7]	Mounting kit CRSMBR	For proximity switches CRSMEO-4	■	■	■	■	41
[8]	Proximity switch CRSMEO-4	<ul style="list-style-type: none"> • Round design • For position sensing 	■	■	■	■	41
[9]	Swivel mounting CRSBN	For bearing caps	■	■	-	-	38
[10]	Flange mounting CRFBN	For bearing caps	■	■	-	-	39
[11]	Foot mounting CRHBN	For bearing caps	■	■	-	-	38
[12]	Rod clevis CRSG	Permits a swivelling movement of the cylinder in one plane	■	■	■	■	41
[13]	Rod eye CRSGS	With spherical bearing	■	■	■	■	41
[14]	Self-aligning rod coupler CRFK	To compensate for radial and angular deviations	■	■	■	■	41

Peripherals overview

CRDSNU-12 ... 25-...S2 – Through piston rod

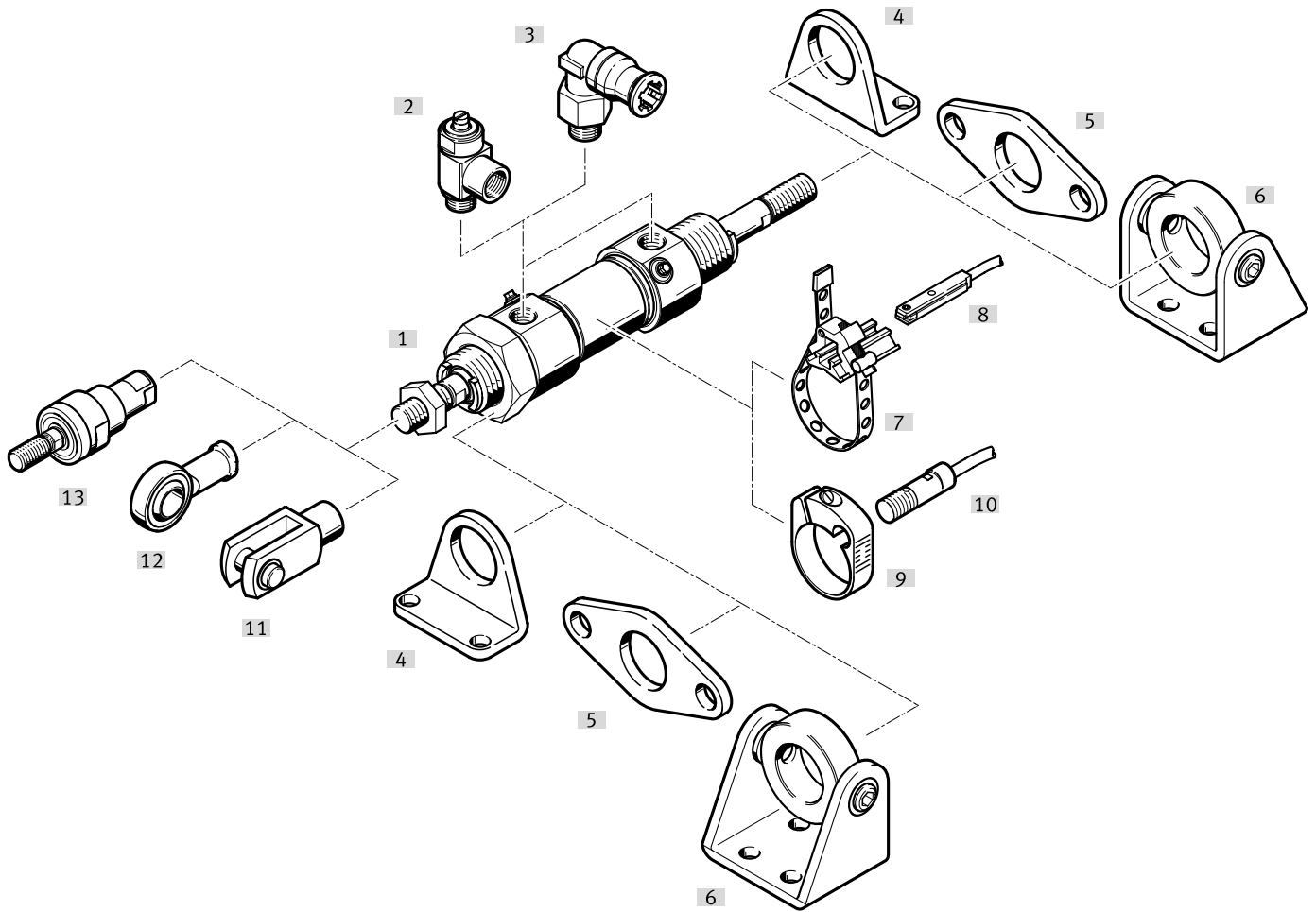

Peripherals overview

Mounting attachments and accessories		Description	→ Page/ Internet
[1]	Standards-based cylinder with through piston rod CRDSNU-12 ... 25-...S2		
[2]	One-way flow control valve CRGRLA	For regulating speed	43
[3]	Push-in fitting CRQS	For connecting tubing with standard O.D.	qs
[4]	Foot mounting CRHBN	For bearing and end caps	38
[5]	Flange mounting CRFBN	For bearing and end caps	39
[6]	Swivel mounting CRSBN	For bearing and end caps	38
[7]	Mounting kit SMBR	For proximity switches CRSMT-8	43
[8]	Proximity switch CRSMT-8M	<ul style="list-style-type: none"> • Design for T-slot • For position sensing 	41
[9]	Mounting kit CRSMBR	For proximity switches CRSMEO-4	41
[10]	Proximity switch CRSMEO-4	<ul style="list-style-type: none"> • Round design • For position sensing 	41
[11]	Rod clevis CRSG	Permits a swivelling movement of the cylinder in one plane	41
[12]	Rod eye CRSGS	With spherical bearing	41
[13]	Self-aligning rod coupler CRFK	To compensate for radial and angular deviations	41

Type codes



001	Series
CRDSNU	Round cylinder, double-acting, stainless steel
002	Piston diameter [mm]
12	12
16	16
20	20
25	25
003	Stroke range [mm]
...	1 ... 500
004	Cushioning
P	Elastic cushioning rings/plates on both sides
PPS	Pneumatic cushioning, self-adjusting at both ends
PPV	Pneumatic cushioning, adjustable at both ends
005	Position sensing
A	For proximity sensor
006	Cylinder end cap
	Standard
MQ	Short end cap without swivel mounting
MG	Bearing cap without mounting thread
007	Scraper variant
	None
A1	Increased chemical resistance
A2	Hard scraper
A3	For unlubricated operation

008	Piston rod type
	At one end
S2	Through piston rod
009	Piston rod thread type
	Male thread
K3	Female thread
010	Custom thread
"M10"K5	M10
011	Piston rod extension
	None
...K8	1 ... 500 mm
012	Temperature resistance
	Standard
S6	Heat-resistant seals max. 120 °C
013	Temperature range
	Standard
TT	-40 ... +80°C
014	EU certification
	None
EX4	II 2GD

Datasheet

P cushioning



-  - Diameter
12 ... 25 mm
-  - Stroke length
1 ... 500 mm
Longer strokes on request
-  - Spare parts service



General technical data

Piston \varnothing		12	16	20	25
Pneumatic connection		M5	M5	G1/8	G1/8
Piston rod thread		M6	M6	M8	M10x1.25
Design		Piston			
		Piston rod			
		Cylinder barrel			
Cushioning	P	Elastic cushioning rings/plates at both ends			
	PPV	-		Cushioning, adjustable at both ends	
	PPS	-		Cushioning, self-adjusting at both ends	
Cushioning length	PPV [mm]	-		15	17
	PPS [mm]	-		15	17
Position sensing		Via proximity switch			
Type of mounting		With accessories			
		With male thread			
Mounting position		Any			

Operating conditions

Operating medium		Compressed air to ISO 8573-1:2010 [7:4:4]			
Note on the operating/ pilot medium		Lubricated operation possible (in which case lubricated operation will always be required)			
Operating pressure ¹⁾	[MPa]	0.1 ... 1			
	[bar]	1 ... 10			
	[psi]	14.5 ... 145			

1) An increase in the minimum operating pressure is possible with variants

Environmental conditions

Standards-based cylinder		Basic type/A3	A1	TT	S6
Ambient temperature ¹⁾	[°C]	-20 ... +80	0 ... +80	-40 ... +80	0 ... +120
Corrosion resistance class CRC ²⁾		3 - High corrosion stress			

1) Note operating range of proximity switches

2) More information: www.festo.com/x/topic/crc

Datasheet

ATEX ¹⁾	
ATEX category for gas	II 2G
Type of ignition protection for gas	Ex h IIC T4 Gb
ATEX category for dust	II 2D
Type of ignition protection for dust	Ex h IIICT120°C Db
Explosion-proof ambient temperature	-20 °C ≤ Ta ≤ +60 °C
CE marking (see declaration of conformity)	To EU Explosion Protection Directive (ATEX)
Explosion protection certification outside the EU	EPL Gb (GB)
	EPL Db (GB)

1) Note the ATEX certification of the accessories.

Forces [N] and impact energy [J]				
Piston ø	12	16	20	25
Theoretical force at 0.6 MPa (6 bar, 87 psi), advancing	68	121	188	295
Theoretical force at 0.6 MPa (6 bar, 87 psi), retracting	51	104	158	247
Impact energy in the end positions for P cushioning ¹⁾	0.07	0.15	0.20	0.30

1) The values are reduced by approx. 50% at an ambient temperature of 80 °C

Weight [g]				
Piston ø	12	16	20	25
Basic weight with 0 mm stroke	101	130	310	410
Additional weight per 10 mm stroke	4	5	7	11
Moving mass with 0 mm stroke	19	21	42	73
Additional mass per 10 mm stroke	2	2	4	6

Datasheet

Max. transverse force F_q as a function of projection l

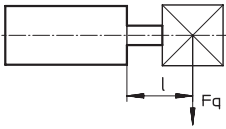

Basic version

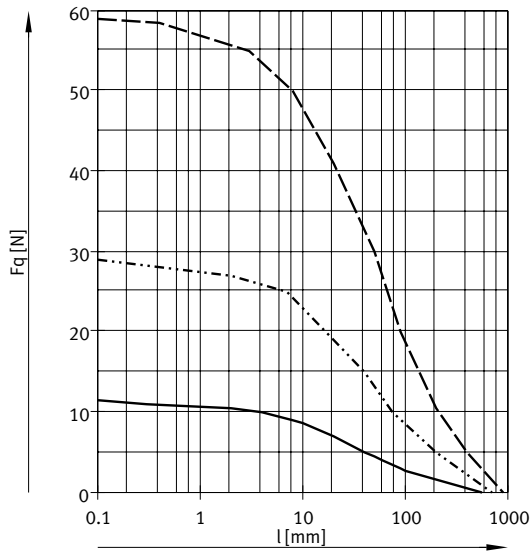

S2 – Through piston rod

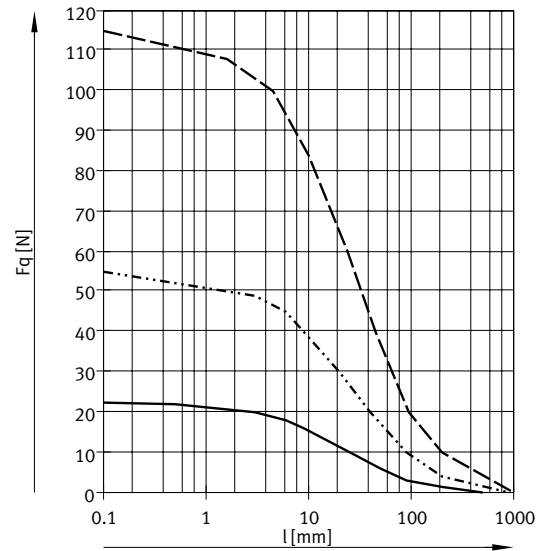

- DSNU-12/16
- ⋯ DSNU-20
- - - DSNU-25

Materials

Sectional view

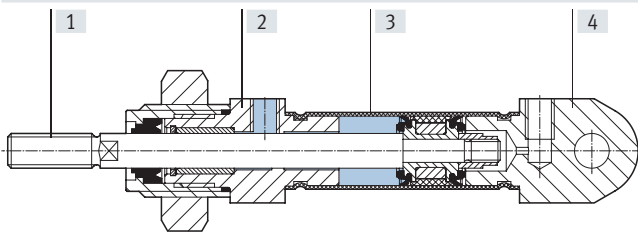

Standards-based cylinder	Basic version	A1	A3	TT	S6
[1] Piston rod	High-alloy stainless steel				
[2] Bearing cap	High-alloy stainless steel				
[3] Cylinder barrel	High-alloy stainless steel				
[4] End cap	High-alloy stainless steel				
- Seals	TPE-U (PUR) media seal (modified for resistance to hydrolysis and cleaning)	FPM	UHMW-PE	TPE-U (PUR) (suitable for low temperatures)	FPM
Note on materials	RoHS-compliant				
Cleanroom class	Class 5 to ISO 14644-1				
LABS (PWIS) conformity	VDMA 24364-B2-L		VDMA 24364-Zone III	VDMA 24364-B2-L	
Food-safe	See declaration of conformity ¹⁾				

1) For information about the area of use, see the declaration of conformity at: www.festo.com/certificates/crdsnu_pub

Datasheet

Dimensions

Download CAD data → www.festo.com

Basic version

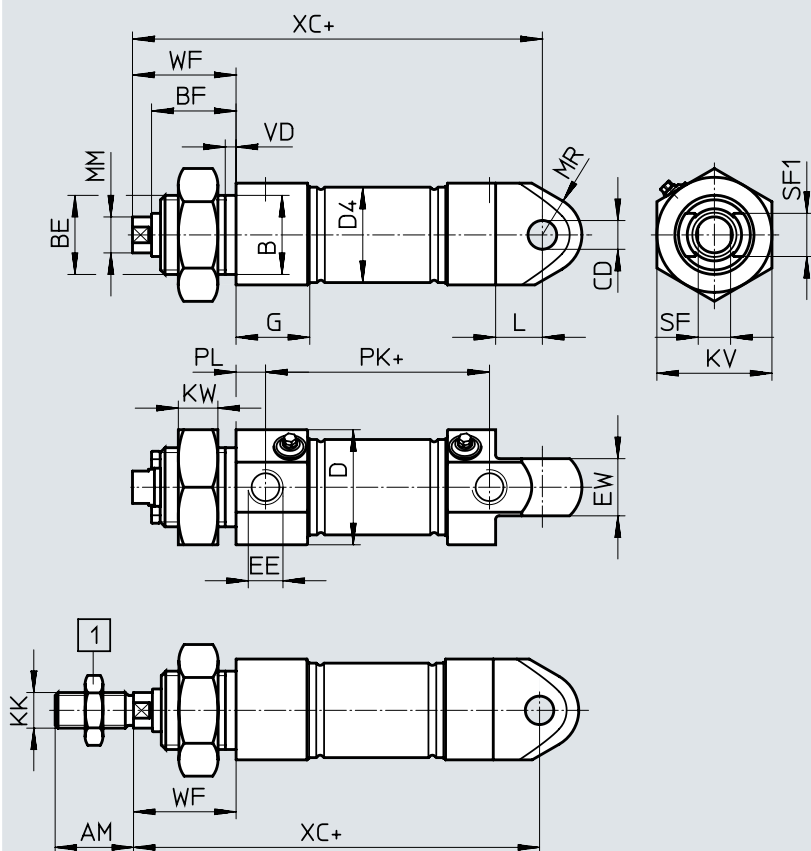

- - **Note**
 [1] Piston rod nut is not included in the scope of delivery for diameter 8 ... 20.
 + = plus stroke length

∅ [mm]	AM	B ∅ h9	BE	BF	CD ∅ H8	D ∅	D4 ∅
12	16	16	M16x1.5	18	6	20	13.3
16	16	16	M16x1.5	18	6	20	17.3
20	20	22	M22x1.5	20.7	8	30	21.3
25	22	22	M22x1.5	23.5	8	32	26.5

∅ [mm]	EE	EW	G	KK	KV	KW	L	MM ∅
12	M5	12	9.5	M6	24	8	10	6
16	M5	12	9.7	M6	24	8	10	6
20	G1/8	16	20.5	M8	32	11	13	8
25	G1/8	16	20.5	M10x1.25	32	11	13	10

∅ [mm]	MR	PL	ST	SF1	VD	WF	XC ±1
12	8	6	5	9	3.5	22	75
16	8	6	5	9	3.5	22	82
20	11	8.2	7	12	3.5	24	95
25	11	8.2	9	12	3.5	28	104

Datasheet

Dimensions

Download CAD data → www.festo.com

MQ – Short end cap without swivel mounting

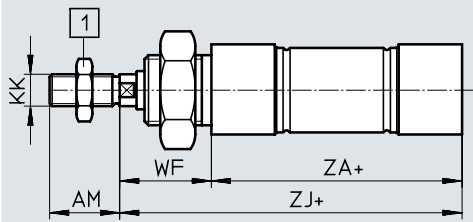

MG – Bearing cap without mounting thread

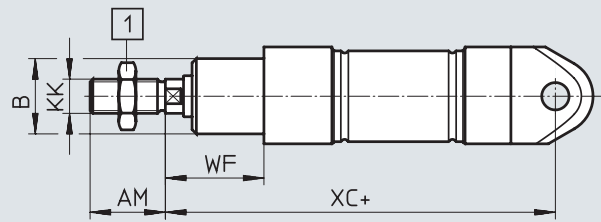

MQ-K3 – Short end cap without swivel mounting, with female piston rod thread

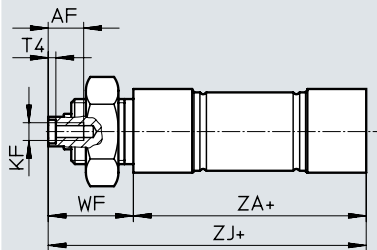

MG-K3 – Bearing cap without mounting thread, with female piston rod thread

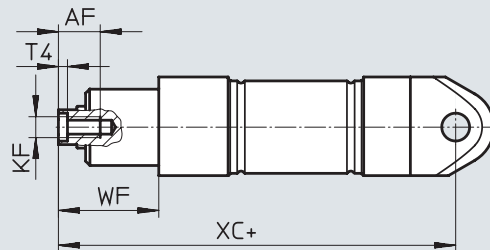

S2 – Through piston rod

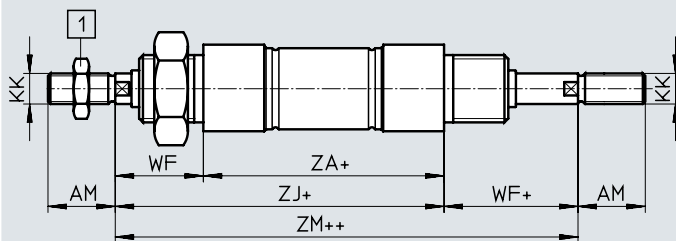

S2-K3 – Through piston rod, with female thread

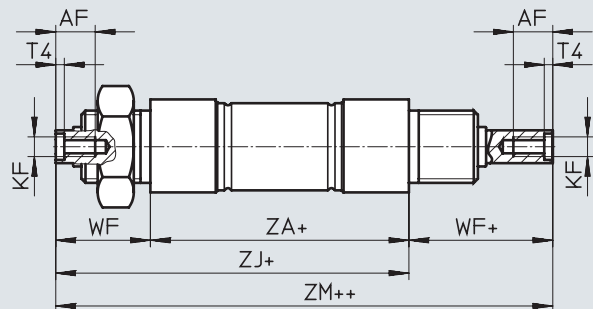

- [1] - Note

[1] Piston rod nut is not included in the scope of delivery for diameter 8 ... 20.

+ = plus stroke length

++ = plus 2x stroke length

∅	AF	AM	B	KF	KK
[mm]			∅ h9		
12	–	16	16	–	M6
16	–	16	16	–	M6
20	12	20	22	M4	M8
25	12	22	22	M6	M10x1.25

∅	T4	WF	XC	ZA	ZJ	ZM
[mm]			±1			
12	–	22	75	50	72	95
16	–	22	82	56	78	101
20	2	24	95	68	92	117
25	2.6	28	104	69.5	97.5	126

Datasheet

Dimensions

Download CAD data → www.festo.com

K2 – Extended male piston rod thread

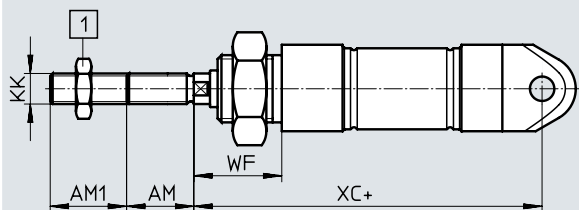

K3 – Female piston rod thread

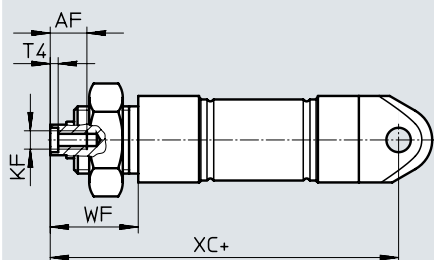

K5 – Special piston rod thread

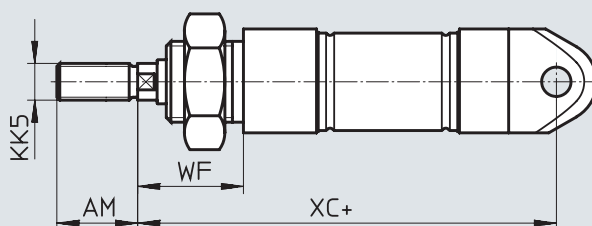

K8 – Extended piston rod

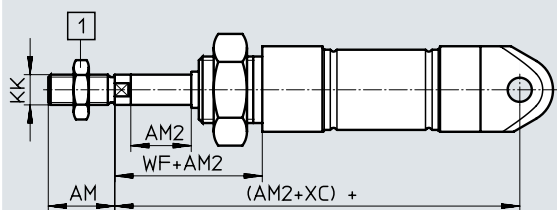

K3-K8 – Extended piston rod, with female thread

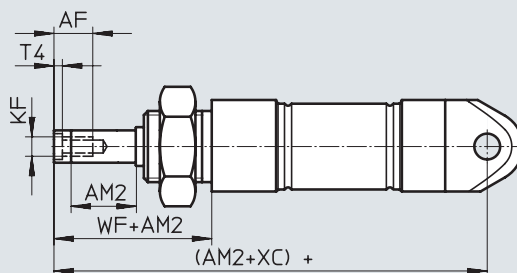

TT – Low temperature / A2 – Hard wiper

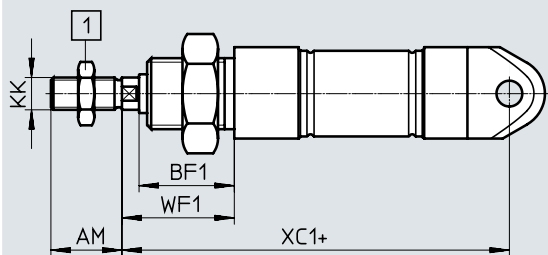

-  - **Note**
 [1] Piston rod nut is not included in the scope of delivery for diameter 8 ... 20.
 + = plus stroke length

Datasheet

∅ [mm]	AF	AM	AM1 max.	AM2 max.
12	–	16	1 ... 20	1 ... 100
16	–	16	1 ... 20	1 ... 100
20	12	20	1 ... 25	1 ... 100
25	12	22	1 ... 35	1 ... 100

∅ [mm]	BF1	KF	KK	KK5
12	24	–	M6	–
16	24	–	M6	–
20	26.7	M4	M8	–
25	29.5	M6	M10x1.25	M10

∅ [mm]	T4	WF	WF1	XC ±1	XC1 ±1
12	–	22	28	75	81
16	–	22	28	82	88
20	2	24	30	95	101
25	2.6	28	34	104	110

Ordering data

Ordering data			
Type	Piston ø	Stroke	P – Elastic cushioning rings/plates A – With position sensing
	[mm]	[mm]	Part no. Type
	12	10	8152524 CRDSNU-12-10-P-A
		25	8152525 CRDSNU-12-25-P-A
		40	8152526 CRDSNU-12-40-P-A
		50	8152527 CRDSNU-12-50-P-A
		80	8152528 CRDSNU-12-80-P-A
		100	8152529 CRDSNU-12-100-P-A
	16	10	8152548 CRDSNU-16-10-P-A
		15	8152549 CRDSNU-16-15-P-A
		20	8152550 CRDSNU-16-20-P-A
		25	8152551 CRDSNU-16-25-P-A
		40	8152552 CRDSNU-16-40-P-A
		50	8152553 CRDSNU-16-50-P-A
		80	8152554 CRDSNU-16-80-P-A
		100	8152555 CRDSNU-16-100-P-A
	20	10	8152557 CRDSNU-20-10-P-A
		15	8152558 CRDSNU-20-15-P-A
		20	8152559 CRDSNU-20-20-P-A
		25	8152560 CRDSNU-20-25-P-A
		40	8152561 CRDSNU-20-40-P-A
		50	8152562 CRDSNU-20-50-P-A
		80	8152563 CRDSNU-20-80-P-A
100		8152564 CRDSNU-20-100-P-A	
25	10	8152627 CRDSNU-25-10-P-A	
	15	8152628 CRDSNU-25-15-P-A	
	20	8152629 CRDSNU-25-20-P-A	
	25	8152630 CRDSNU-25-25-P-A	
	40	8152631 CRDSNU-25-40-P-A	
	50	8152632 CRDSNU-25-50-P-A	
	80	8152633 CRDSNU-25-80-P-A	
	100	8152634 CRDSNU-25-100-P-A	

Ordering data

Ordering data – Parts in stock				
Type	Piston ø	Stroke	P – Elastic cushioning rings/plates PPS – Pneumatic cushioning, self-adjusting at both ends A – With position sensing MG – Bearing cap without mounting thread A1 – Wiper variant: increased chemical resistance	
			Part no.	Type
	16	10	8073759	CRDSNU-B-16-10-P-A-MG-A1
		25	8073760	CRDSNU-B-16-25-P-A-MG-A1
		40	8073761	CRDSNU-B-16-40-P-A-MG-A1
		50	8073762	CRDSNU-B-16-50-P-A-MG-A1
		80	8073763	CRDSNU-B-16-80-P-A-MG-A1
		100	8073764	CRDSNU-B-16-100-P-A-MG-A1
		125	8073765	CRDSNU-B-16-125-P-A-MG-A1
		160	8073766	CRDSNU-B-16-160-P-A-MG-A1
	200	8073767	CRDSNU-B-16-200-P-A-MG-A1	
	20	10	8073980	CRDSNU-B-20-10-PPS-A-MG-A1
		25	8073979	CRDSNU-B-20-25-PPS-A-MG-A1
		40	8073978	CRDSNU-B-20-40-PPS-A-MG-A1
		50	8073977	CRDSNU-B-20-50-PPS-A-MG-A1
		80	8073976	CRDSNU-B-20-80-PPS-A-MG-A1
		100	8073975	CRDSNU-B-20-100-PPS-A-MG-A1
		125	8073974	CRDSNU-B-20-125-PPS-A-MG-A1
		160	8073973	CRDSNU-B-20-160-PPS-A-MG-A1
	200	8073972	CRDSNU-B-20-200-PPS-A-MG-A1	
	25	10	2159636	CRDSNU-B-25-10-PPS-A-MG-A1
		25	2159637	CRDSNU-B-25-25-PPS-A-MG-A1
		40	2159638	CRDSNU-B-25-40-PPS-A-MG-A1
		50	2159639	CRDSNU-B-25-50-PPS-A-MG-A1
		80	2159640	CRDSNU-B-25-80-PPS-A-MG-A1
		100	2159641	CRDSNU-B-25-100-PPS-A-MG-A1
125		2159642	CRDSNU-B-25-125-PPS-A-MG-A1	
160		2159643	CRDSNU-B-25-160-PPS-A-MG-A1	
200	2159644	CRDSNU-B-25-200-PPS-A-MG-A1		

 **Note**

The bearing cap on stocked parts is made of one piece.
 When ordered using the modular product system, the bearing cap is made of two pieces, which makes it possible to exchange the wiper in the event of a repair.

Ordering data

Ordering table – Modular product system							
Size	12	16	20	25	Conditions	Code	Enter code
Module no.	552787	552788	552789	552790			
Version	Stainless steel					CR	CR
Function	Standards-based cylinder, double-acting, to ISO 6432					DSNU	DSNU
Piston Ø [mm]	12	16	20	25		-...	
Stroke [mm]	1 ... 200		1 ... 320	1 ... 500	[1]	-...	
Cushioning	Elastic cushioning rings/plates at both ends				[10]	-P	
	-		Pneumatic cushioning, self-adjusting		[2] [8]	-PPS	
	-		Pneumatic cushioning, adjustable at both ends			-PPV	
Position sensing	Via proximity switch					-A	-A
Cylinder end cap	Short end cap without swivel mounting					-MQ	
	Bearing cap without mounting thread					-MG	
Wiper variant	Increased chemical resistance				[2]	-A1	
	Hard wiper				[2] [3] [9]	-A2	
	Unlubricated operation				[2]	-A3	
Piston rod type	Through piston rod				[3] [4]	-S2	
Extended male thread	Extended male piston rod thread						
	[mm]	1 ... 20		1 ... 25	1 ... 35		-...K2
Female thread	Piston rod with female thread						
	-	-	(M4)	(M6)	[5]	-K3	
Custom thread	Special piston rod thread						
	-	-	-	M10		-“...”K5	
Extended piston rod [mm]	1 ... 100					-...K8	
Temperature resistance	Heat-resistant seals max. +120 °C					-S6	
Low temperature	-	Seals and lubricating grease from -40 °C ... +80 °C			[3] [6] [9]	-TT	
EU certification (ATEX)	II 2GD				[7]	-EX4	

- [1] -... Longer strokes on request
 [2] PPS, A1, A2, A3 Not with S6, TT
 [3] A2, S2, TT Not with MG
 [4] S2 Not with MQ
 [5] K3 Not with K2, K5
 [6] TT Not with S6
 [7] EX4 Not with S6, TT
 [8] PPS Not with MQ for piston diameter 16
 [9] A2, TT Not with S2, K3
 [10] P Not with B except for piston diameter 16

Key features

Variants

CRDSNU Basic version	CRDSNU-S2: Through piston rod	CRDSNU-MQ: Short end cap without swivel mounting	CRDSNU-MG: Bearing cap without mounting thread
-------------------------	----------------------------------	---	---

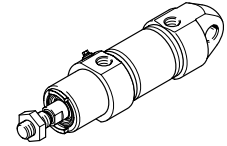
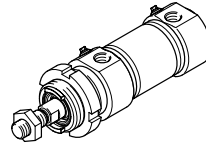
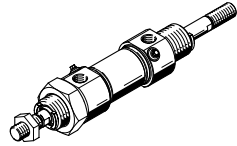
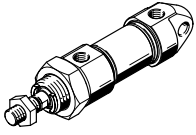

Further variants

Symbol	Key features	Description
	S2 Through piston rod	For working at both ends with the same force in the forward and return stroke, for attaching external stops
	S6 Heat-resistant seals	Temperature resistance up to max. 120 °C
	K2 Extended male piston rod thread	–
	K3 Female piston rod thread	–
	K5 Special piston rod thread	Metric standard thread to ISO
	K8 Extended piston rod	–
	A1 Wiper variant	Increased chemical resistance
	A2 Wiper variant	Hard wiper: Cylinder with hard
	A3 Wiper variant	Unlubricated operation: Cleaning processes degrease the piston rod. A special piston rod seal permits a longer service life compared to the standard seal.
	TT Low temperature	Temperature resistance down to max. –40 °C

Cushioning types

	Cushioning P	Cushioning PPS	Cushioning PPV
Operating mode	<ul style="list-style-type: none"> The drive is fitted with polymer elastic end-position cushioning 	<ul style="list-style-type: none"> The drive is fitted with self-adjusting end-position cushioning 	<ul style="list-style-type: none"> The drive is fitted with adjustable end-position cushioning
Application	<ul style="list-style-type: none"> Small loads Low speeds Low impact energies 	<ul style="list-style-type: none"> Small to medium loads Low to medium speeds Medium impact energies 	<ul style="list-style-type: none"> Medium to large loads High speeds High impact energies
Advantages	<ul style="list-style-type: none"> No adjustment required Saves time 	<ul style="list-style-type: none"> No adjustment required Saves time Powerful 	<ul style="list-style-type: none"> Very powerful

Peripherals overview

CRDSNU-32 ... 100-...

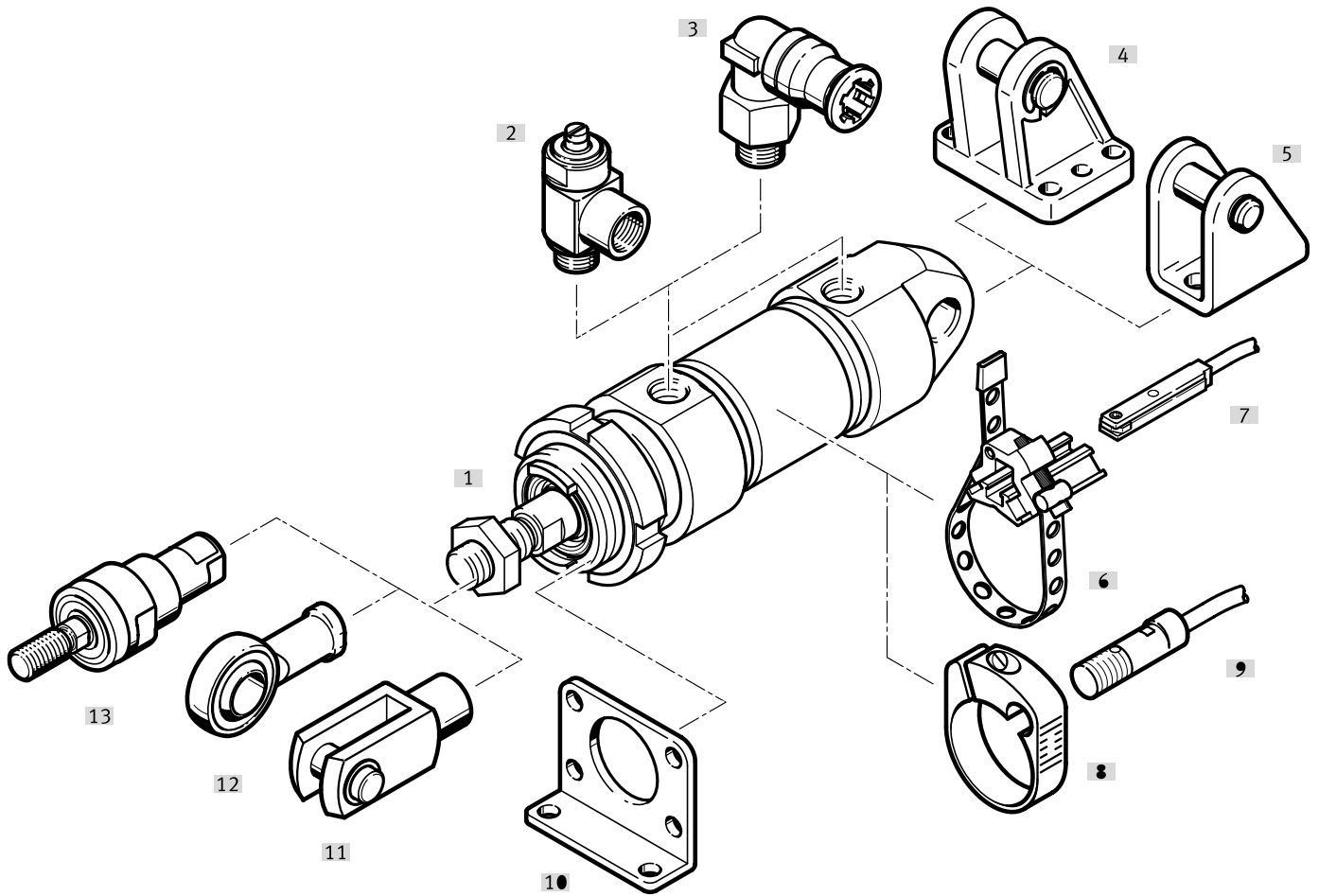

Peripherals overview

Mounting attachments and accessories		Description	CRDSNU-			→ Page/ Internet
			Basic version	MQ	MG	
[1]	Round cylinder CRDSNU-32 ... 100-...					
[2]	One-way flow control valve CRGRLA	For regulating speed	■	■	■	43
[3]	Push-in fitting CRQS	For connecting tubing with standard O.D.	■	■	■	qs
[4]	Clevis foot CRLBN	For end caps	■	–	■	40
[5]	Clevis foot LBG	For end caps	■	–	■	40
[6]	Mounting kit SMBR	For proximity switches CRSMT-8	■	■	■	43
[7]	Proximity switch CRSMT-8M	<ul style="list-style-type: none"> • Design for T-slot • For position sensing 	■	■	■	41
[8]	Mounting kit CRSMBR	For proximity switches CRSMEO-4	■	■	■	41
[9]	Proximity switch CRSMEO-4	<ul style="list-style-type: none"> • Round design • For position sensing 	■	■	■	41
[10]	Flange mounting CRFV	<ul style="list-style-type: none"> • 1 included in the scope of delivery • For bearing caps 	■	■	–	39
[11]	Rod clevis CRSG	Permits a swivelling movement of the cylinder in one plane	■	■	■	41
[12]	Rod eye CRSGS	With spherical bearing	■	■	■	41
[13]	Self-aligning rod coupler CRFK	To compensate for radial and angular deviations	■	■	■	41

Peripherals overview

CRDSNU-32 ... 100-...-S2 – Through piston rod

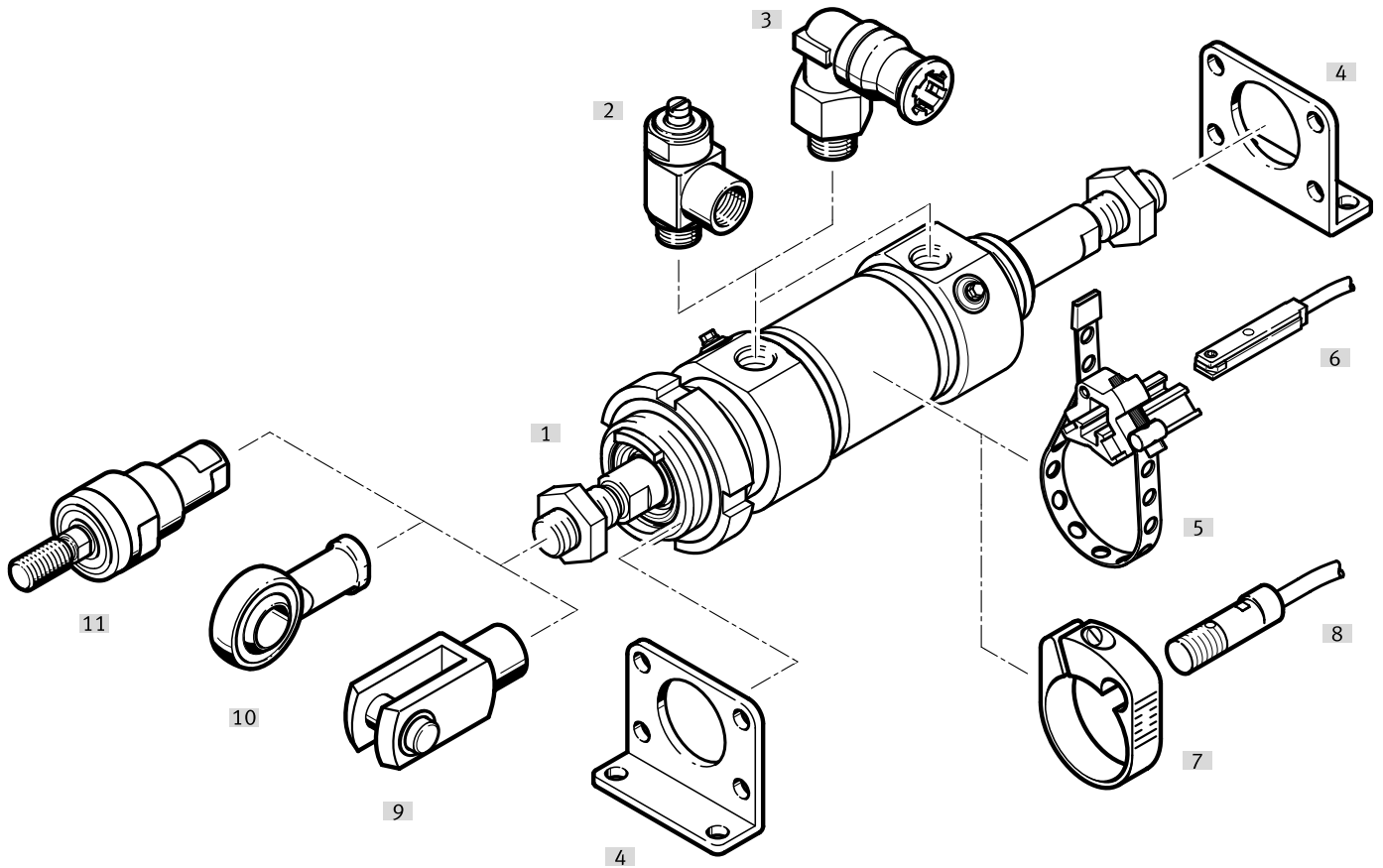

Peripherals overview

Mounting attachments and accessories		Description	→ Page/Internet
[1]	Round cylinders with through piston rod CRDSNU-32 ... 100-...S2		
[2]	One-way flow control valve CRGRLA	For regulating speed	43
[3]	Push-in fitting CRQS	For connecting tubing with standard O.D.	qs
[4]	Foot mounting CRH	<ul style="list-style-type: none"> • 2 included in the scope of delivery • For bearing and end caps 	38
[5]	Mounting kit SMBR	For proximity switches CRSMT-8	43
[6]	Proximity switch CRSMT-8M	<ul style="list-style-type: none"> • Design for T-slot • For position sensing 	41
[7]	Mounting kit CRSMBR	For proximity switches CRSME0-4	41
[8]	Proximity switch CRSME0-4	<ul style="list-style-type: none"> • Round design • For position sensing 	41
[9]	Rod clevis CRSG	Permits a swivelling movement of the cylinder in one plane	41
[10]	Rod eye CRSGS	With spherical bearing	41
[11]	Self-aligning rod coupler CRFK	To compensate for radial and angular deviations	41

Type codes



001	Series	
CRDSNU	Round cylinder, double-acting, stainless steel	
002	Piston diameter	
32	32	
40	40	
50	50	
63	63	
80	80	
100	100	
003	Stroke	
...	1 ... 500	
004	Cushioning	
P	Elastic cushioning rings/plates on both sides	
PPS	Pneumatic cushioning, self-adjusting at both ends	
PPV	Pneumatic cushioning, adjustable at both ends	
005	Position sensing	
A	For proximity sensor	
006	Cylinder end cap	
	Standard	
MQ	Short end cap without swivel mounting	
MG	Bearing cap without mounting thread	
007	Scraper variant	
	None	
A1	Increased chemical resistance	
A2	Hard scraper	
A3	For unlubricated operation	

008	Piston rod type	
	At one end	
S2	Through piston rod	
009	Piston rod thread extension	
	None	
...K2	1 ... 70 mm	
010	Piston rod thread type	
	Male thread	
K3	Female thread	
011	Custom thread	
"M10"K5	M10	
"M12"K5	M12	
"M16"K5	M16	
"M20"K5	M20	
012	Piston rod extension	
	None	
...K8	1 ... 500 mm	
013	Temperature resistance	
	Standard	
S6	Heat-resistant seals max. 120 °C	
014	Temperature range	
	Standard	
TT	-40 ... +80°C	
015	EU certification	
	None	
EX4	II 2GD	

Datasheet

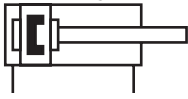
P cushioning



-  Diameter
32 ... 100 mm
-  Stroke length
1 ... 500 mm
Longer strokes on request
-  Spare parts service

General technical data

Piston Ø	32	40	50	63	80	100	
Pneumatic connection	G1/8	G1/4	G1/4	G3/8	G3/8	G1/2	
Piston rod thread	M10x1.25	M12x1.25	M16x1.5	M16x1.5	M20x1.5	M20x1.5	
Design	Piston						
	Piston rod						
	Cylinder barrel						
Cushioning	P	Elastic cushioning rings/plates at both ends					
	PPV	Cushioning, adjustable at both ends					
	PPS	Cushioning, self-adjusting at both ends					
Cushioning length	PPV [mm]	14	18	20	21	31	31
	PPS [mm]	14	18	20	21	31	31
Position sensing	Via proximity switch						
Type of mounting	With accessories						
	With male thread						
Mounting position	Any						

Operating conditions

Operating medium	Compressed air to ISO 8573-1:2010 [7:4:4]					
Note on the operating/ pilot medium	Lubricated operation possible (in which case lubricated operation will always be required)					
Operating pressure ¹⁾	[MPa]	0.1 ... 1				
	[bar]	1 ... 10				
	[psi]	14.5 ... 145				

1) An increase in the minimum operating pressure is possible with variants

Environmental conditions

Standards-based cylinder	Basic type/A3	A1	TT	S6
Ambient temperature ¹⁾ [°C]	-20 ... +80	0 ... +80	-40 ... +80	0 ... +120
Corrosion resistance class CRC				
Ø 32 ... 63	3 - High corrosion stress ²⁾			
Ø 80 ... 100	4 - Particularly high corrosion stress. ²⁾			

1) Note operating range of proximity switches

2) More information: www.festo.com/x/topic/crc

Datasheet

ATEX ¹⁾	
ATEX category for gas	II 2G
Type of ignition protection for gas	Ex h IIC T4 Gb
ATEX category for dust	II 2D
Type of ignition protection for dust	Ex h IIICT120°C Db
Explosion-proof ambient temperature	-20 °C ≤ Ta ≤ +60 °C
CE marking (see declaration of conformity)	To EU Explosion Protection Directive (ATEX)
Explosion protection certification outside the EU	EPL Gb (GB)
	EPL Db (GB)

1) Note the ATEX certification of the accessories.

Forces [N] and impact energy [J]						
Piston ø	32	40	50	63	80	100
Theoretical force at 0.6 MPa (6 bar, 87 psi), advancing	483	754	1178	1870	3016	4712
Theoretical force at 0.6 MPa (6 bar, 87 psi), retracting	415	633	990	1682	2721	4418
Impact energy in the end positions for P cushioning ¹⁾	0.4	0.7	1.0	1.3	1.8	2.5

1) The values are reduced by approx. 50% at an ambient temperature of 80 °C

Weight [g]						
Piston ø	32	40	50	63	80	100
Basic weight with 0 mm stroke	670	1327	2020	2943	5891	8527
Additional weight per 10 mm stroke	15	24	40	44	68	75
Moving mass with 0 mm stroke	118	232	416	472	860	1018
Additional mass per 10 mm stroke	9	16	25	25	39	39

Datasheet

Max. transverse force F_q as a function of projection l

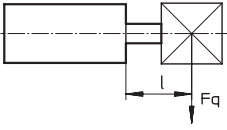

Basic version

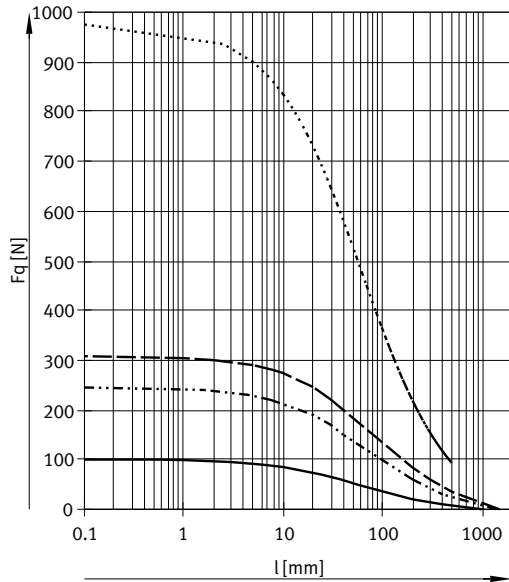

S2 – Through piston rod

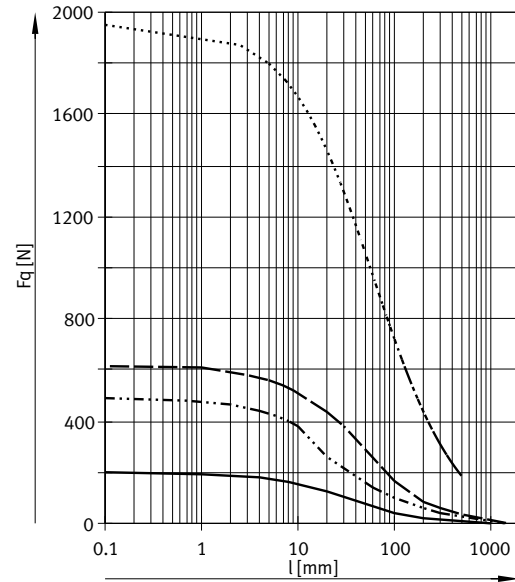

- DSNU-32
- DSNU-40
- - - DSNU-50/63
- · - · DSNU-80/100

Materials

Sectional view

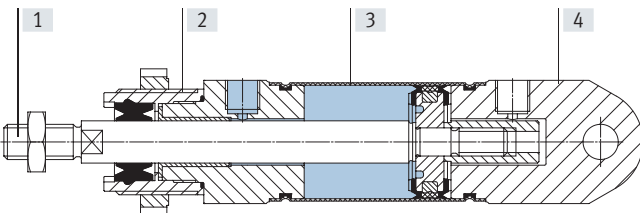

Standards-based cylinder	Basic version	A1	A3	TT	S6
[1] Piston rod	High-alloy stainless steel				
[2] Bearing cap	High-alloy stainless steel				
[3] Cylinder barrel	High-alloy stainless steel				
[4] End cap	High-alloy stainless steel				
- Seals	TPE-U (PUR) media seal (modified for resistance to hydrolysis and cleaning)	FPM	UHMW-PE	TPE-U (PUR) (suitable for low temperatures)	FPM
Note on materials	RoHS-compliant				
Cleanroom class	Class 5 to ISO 14644-1				
LABS (PWIS) conformity	VDMA 24364-B2-L		VDMA 24364-Zone III	VDMA 24364-B2-L	
Food-safe	See declaration of conformity ¹⁾				

1) For information about the area of use, see the declaration of conformity at: www.festo.com/certificates/crdsnu_pub

Datasheet

Dimensions

Download CAD data → www.festo.com

Basic version

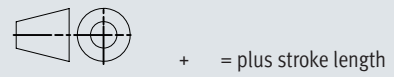
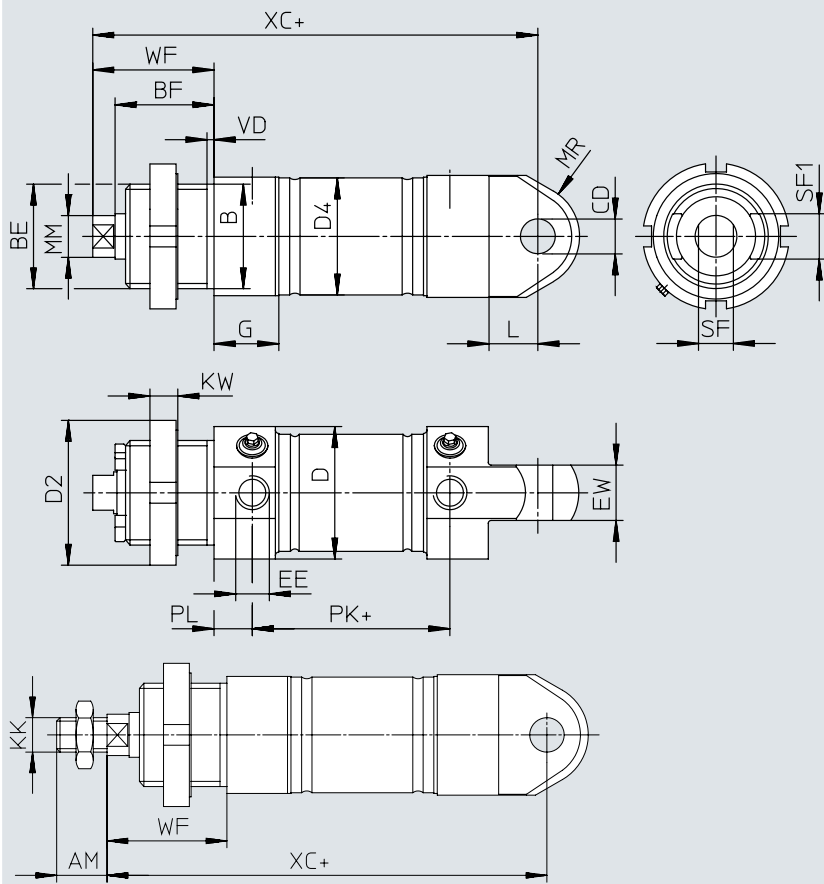

Datasheet

∅ [mm]	AM	B ∅ h9	BE	BF	CD ∅ H8	D ∅	D2 ∅	D4 ∅
32	22	30	M30x1.5	28.4	10	38	42	33.6
40	24	38	M38x1.5	32	12	49	50	41.6
50	32	45	M45x1.5	36.4	16	57	60	52.4
63	32	45	M45x1.5	36.4	16	70	60	65.4
80	40	50	M50x2	42.2	20	88	75	82.8
100	40	50	M50x2	42.2	20	108	75	102.8

∅ [mm]	EE	EW	G	KK	KW	L	MM ∅
32	G1/8	16	18.6	M10x1.25	8	14	12
40	G1/4	18	24.7	M12x1.25	10	16	16
50	G1/4	21	24.4	M16x1.5	10	17	20
63	G3/8	21	27.4	M16x1.5	10	17	20
80	G3/8	35	32.4	M20x1.5	13	22	25
100	G1/2	35	32.4	M20x1.5	13	22	25

∅ [mm]	MR	PL	ST	SF1	VD	WF	XC ±1
32	15	9	10	13	4.3	34	118
40	19	12	13	18	4.3	39	140
50	22.5	12	17	22	4.3	44	147
63	22.5	13	17	22	4.3	44	156
80	30	16	22	22	4.5	50	193
100	36	16	22	22	4.5	50	196

Datasheet

Dimensions

Download CAD data → www.festo.com

MQ – Short end cap without swivel mounting

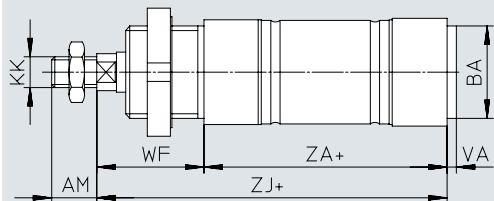

MG – Bearing cap without mounting thread

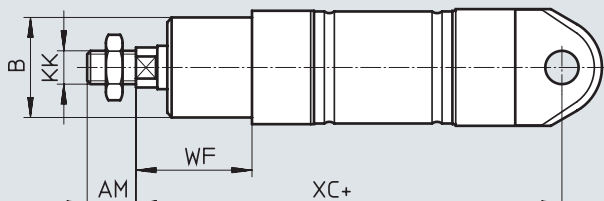

MQ-K3 – Short end cap without swivel mounting, with female piston rod thread

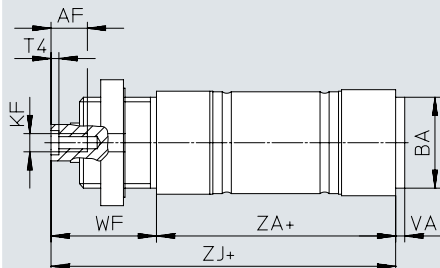

MG-K3 – Bearing cap without mounting thread, with female piston rod thread

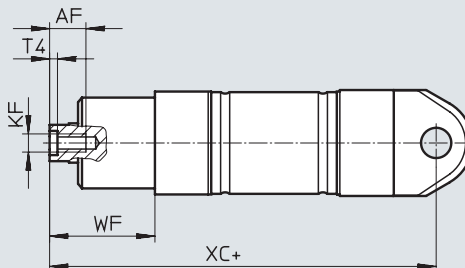

S2 – Through piston rod

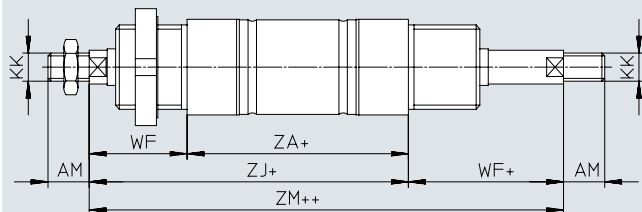

S2-K3 – Through piston rod, with female thread

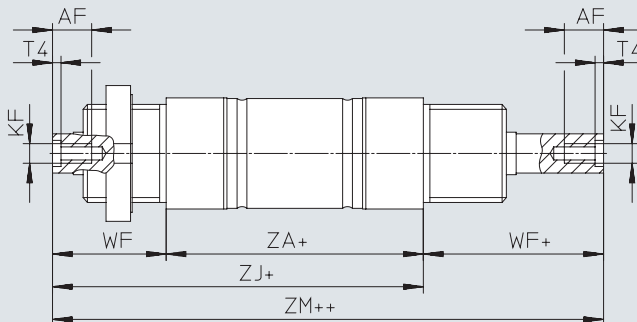

+ = plus stroke length
 ++ = plus 2x stroke length

Datasheet

∅ [mm]	AF	AM	B ∅ h9	BA h9	KF	KK
32	12	22	30	30	M6	M10x1.25
40	12	24	38	38	M8	M12x1.25
50	16	32	45	45	M10	M16x1.5
63	16	32	45	45	M10	M16x1.5
80	20	40	50	45	M12	M20x1.5
100	20	40	50	55	M12	M20x1.5

∅ [mm]	T4	VA	WF	XC ±1	ZA	ZJ	ZM
32	2.6	3	34	118	69.5	104	138
40	3.3	4	39	140	84.6	124	163
50	4.7	4	44	147	86.2	130	175
63	4.7	4	44	156	94.2	139	183
80	6.1	4	50	193	120.7	171	221
100	6.1	4	50	196	123.7	174	224

Datasheet

Dimensions

Download CAD data → www.festo.com

K2 – Extended male piston rod thread

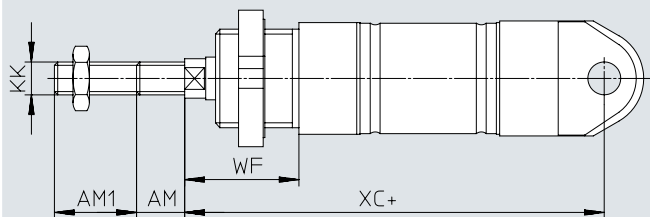

K3 – Female piston rod thread

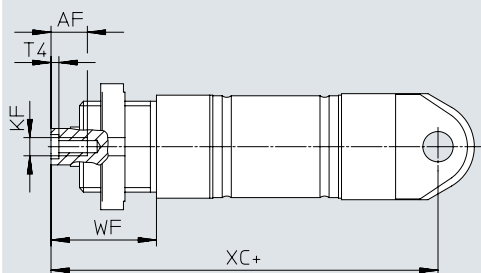

K5 – Special piston rod thread

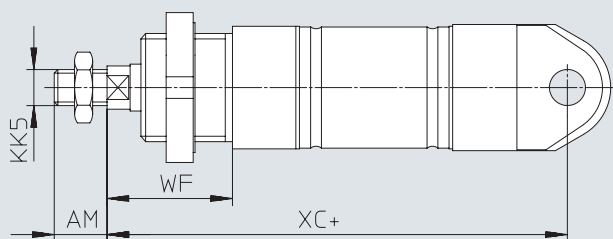

K8 – Extended piston rod

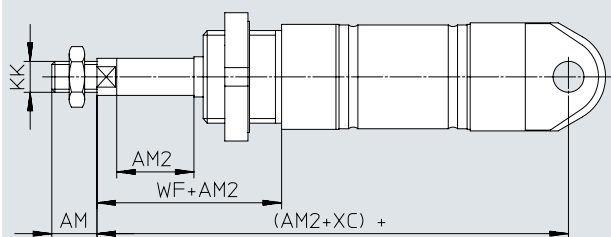

K3-K8 – Extended piston rod, with female thread

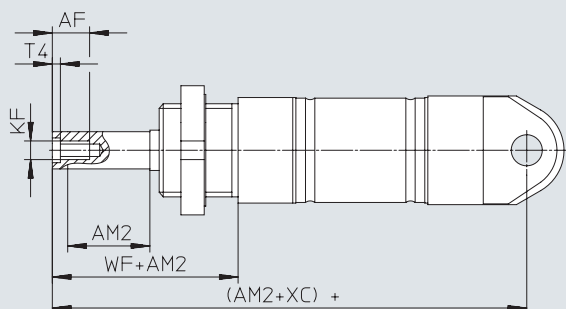

TT – Low temperature / A2 – Hard wiper

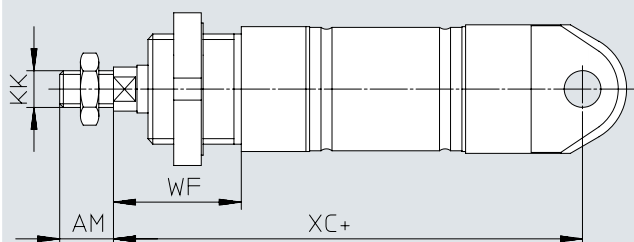

+ = plus stroke length

Datasheet

∅ [mm]	AF	AM	AM1 max.	AM2 max.	KF
32	12	22	1 ... 35	1 ... 500	M6
40	12	24	1 ... 35	1 ... 500	M8
50	16	32	1 ... 70	1 ... 500	M10
63	16	32	1 ... 70	1 ... 500	M10
80	20	40	1 ... 70	1 ... 500	M12
100	20	40	1 ... 70	1 ... 500	M12

∅ [mm]	KK	KK5	T4	WF	XC ±1
32	M10x1.25	M10	2.6	34	118
40	M12x1.25	M12	3.3	39	140
50	M16x1.5	M16	4.7	44	147
63	M16x1.5	M16	4.7	44	156
80	M20x1.5	M20	6.1	50	193
100	M20x1.5	M20	6.1	50	196

Ordering data

Ordering data				
Type	Piston ø	Stroke	P – Elastic cushioning rings/plates	
	[mm]		Part no.	Type
	32	10	8152637	CRDSNU-32-10-P-A
		25	8152638	CRDSNU-32-25-P-A
		40	8152639	CRDSNU-32-40-P-A
		50	8152640	CRDSNU-32-50-P-A
		80	8152641	CRDSNU-32-80-P-A
		100	8152642	CRDSNU-32-100-P-A

Ordering data – Parts in stock				
Type	Piston ø	Stroke	PPS – Pneumatic cushioning, self-adjusting at both ends	
	[mm]		Part no.	Type
	32	10	2176399	CRDSNU-B-32-10-PPS-A-MG-A1
		25	2176400	CRDSNU-B-32-25-PPS-A-MG-A1
		40	2176401	CRDSNU-B-32-40-PPS-A-MG-A1
		50	2176402	CRDSNU-B-32-50-PPS-A-MG-A1
		80	2176403	CRDSNU-B-32-80-PPS-A-MG-A1
		100	2176404	CRDSNU-B-32-100-PPS-A-MG-A1
		125	2176405	CRDSNU-B-32-125-PPS-A-MG-A1
		160	2176406	CRDSNU-B-32-160-PPS-A-MG-A1
		200	2176407	CRDSNU-B-32-200-PPS-A-MG-A1
		40	10	8073989
	25		8073988	CRDSNU-B-40-25-PPS-A-MG-A1
	40		8073987	CRDSNU-B-40-40-PPS-A-MG-A1
	50		8073986	CRDSNU-B-40-50-PPS-A-MG-A1
	80		8073985	CRDSNU-B-40-80-PPS-A-MG-A1
	100		8073984	CRDSNU-B-40-100-PPS-A-MG-A1
	125		8073983	CRDSNU-B-40-125-PPS-A-MG-A1
	160		8073982	CRDSNU-B-40-160-PPS-A-MG-A1
	200		8073981	CRDSNU-B-40-200-PPS-A-MG-A1

 **Note**

The bearing cap on stocked parts is made of one piece.
When ordered using the modular product system, the bearing cap is made of two pieces, which makes it possible to exchange the wiper in the event of a repair.

Ordering data

Ordering table – Modular product system										
Size	32	40	50	63	80	100	Conditions	Code	Enter code	
Module no.	552791	552792	552793	552794	8126418	8126417				
Version	Stainless steel							CR	CR	
Function	Round cylinder, double-acting							DSNU	DSNU	
Piston Ø [mm]	32	40	50	63	80	100		-...		
Stroke [mm]	1 ... 500						[1]	-...		
Cushioning	Elastic cushioning rings/plates at both ends							-P		
	Pneumatic cushioning, self-adjusting						[2]	-PPS		
	Pneumatic cushioning, adjustable at both ends							-PPV		
Position sensing	Via proximity switch							-A	-A	
Cylinder end cap	Short end cap without swivel mounting							-MQ		
	Bearing cap without mounting thread							-MG		
Wiper variant	Increased chemical resistance						[2]	-A1		
	Hard wiper				-		[2] [3]	-A2		
	Unlubricated operation						[2]	-A3		
Piston rod type	Through piston rod						[3] [4]	-S2		
Extended male thread	Extended male piston rod thread									
[mm]	1 ... 35		1 ... 70							-...K2
Female thread	Piston rod with female thread									
	M6	M8	M10	M10	M12	M12	[5]	-K3		
Custom thread	Special piston rod thread									
	M10	M12	M16	M16	M20	M20		-“...”K5		
Extended piston rod [mm]	1 ... 500							-...K8		
Temperature resistance	Heat-resistant seals max. +120 °C							-S6		
Low temperature	Seals and lubricating grease from -40 °C ... +80 °C				-		[3] [6]	-TT		
EU certification (ATEX)	II 2GD						[7]	-EX4		

- [1] -... Longer strokes on request
 [2] PPS, A1, A2, A3 Not with S6, TT
 [3] A2, S2, TT Not with MG
 [4] S2 Not with MQ
 [5] K3 Not with K2, K5
 [6] TT Not with S6
 [7] EX4 Not with S6, TT

Accessories

Foot mounting CRHBN

Scope of delivery:
CRHBN-... x1: 1 foot
CRHBN-... x2: 2 feet, 1 nut

Material:
High-alloy steel

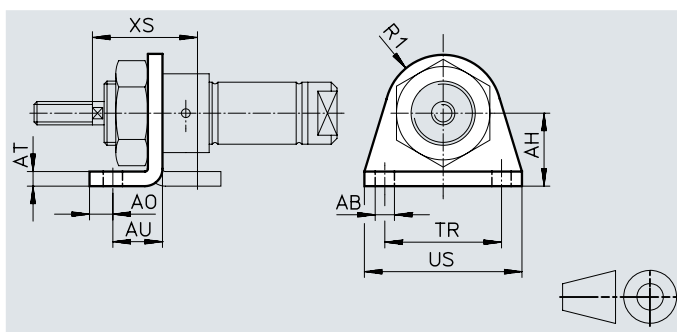

Dimensions and ordering data													
For \varnothing	AB \varnothing	AH	AO	AT	AU	R1	TR	US	XS	CRC ¹⁾	Weight	Part no.	Type
[mm]											[g]		
12	5.5	20	6	4	14	13	32	42	32	4	43	161866	CRHBN-12/16x1
16	5.5	20	6	4	14	13	32	42	32	4	107	162999	CRHBN-12/16x2
20	6.6	25	8	5	17	20	40	54	36	4	94	161867	CRHBN-20/25x1
25	6.6	25	8	5	17	20	40	54	40	4	236	162998	CRHBN-20/25x2

1) More information: www.festo.com/x/topic/crc

Foot mounting CRH

Material:
High-alloy steel

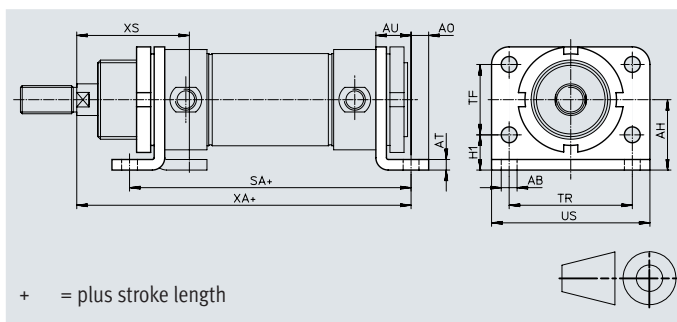

Dimensions and ordering data																
For \varnothing	AB \varnothing	AH	AO	AT	AU	H1	SA	TF	TR	US	XA	XS	CRC ¹⁾	Weight	Part no.	Type
[mm]														[g]		
32	7	28	7	4	14	14	124	28	52	66	148	48	4	237	162951	CRH-32
40	9	33	10	5	20	18	153	30	60	80	178	60	4	341	162952	CRH-40
50	9	40	10	6	20	20	160	40	70	90	190	64	4	559	162953	CRH-50
63	9	45	10	6	20	20	164	50	76	96	195	64	4	680	162954	CRH-63

1) More information: www.festo.com/x/topic/crc

Swivel mounting CRSBN

Material:
High-alloy steel

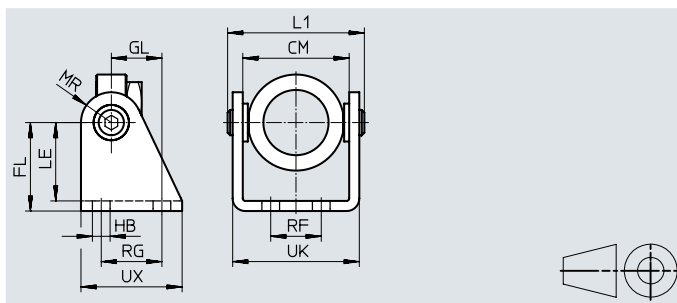
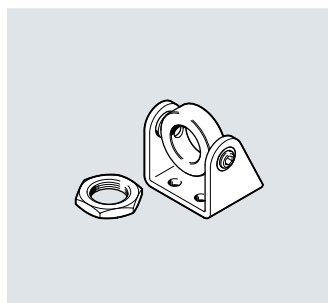

Dimensions and ordering data															
For \varnothing	CM	FL	GL	HB \varnothing	L1	LE	MR	RF	RG	UK	UX	CRC ¹⁾	Weight	Part no.	Type
[mm]													[g]		
20	38.1	35	20	7	55	31	12	20	24	50.1	40	4	230	552904	CRSBN-20/25
25															

1) More information: www.festo.com/x/topic/crc

Accessories

Flange mounting CRFBN

Material:
High-alloy steel

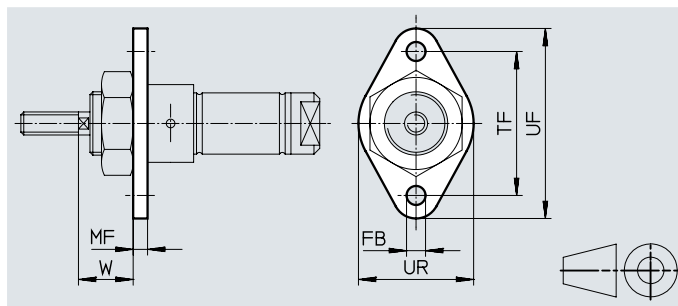

Dimensions and ordering data

For \varnothing	FB \varnothing	MF	TF	UF	UR	W	CRC ¹⁾	Weight	Part no.	Type
[mm]								[g]		
12, 16	5.5	4	40	53	30	18	4	26	161864	CRFBN-12/16
20	6.6	5	50	66	40	19	4	52	161865	CRFBN-20/25
25	6.6	5	50	66	40	23	4	52	161865	CRFBN-20/25

1) More information: www.festo.com/x/topic/crc

Flange mounting CRFV

Material:
High-alloy steel

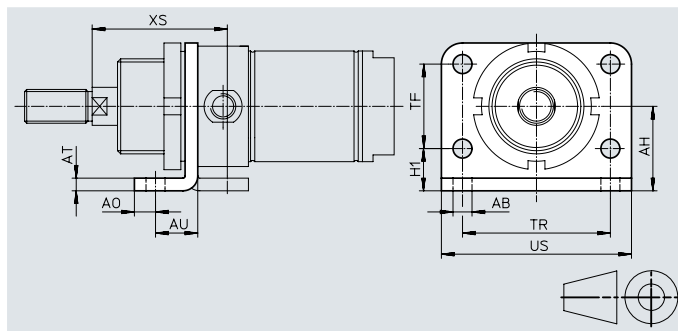

Dimensions and ordering data

For \varnothing	AB \varnothing	AH	AO	AT	AU	H1	TF	TR	US	XS	CRC ¹⁾	Weight	Part no.	Type
[mm]												[g]		
32	7	28	7	4	14	14	28	52	66	48	4	102	161858	CRFV-32
40	9	33	10	5	20	18	30	60	80	60	4	190	161859	CRFV-40
50	9	40	10	6	20	20	40	70	90	64	4	290	161860	CRFV-50
63	9	45	10	6	20	20	50	76	96	64	4	365	161861	CRFV-63

1) More information: www.festo.com/x/topic/crc

Accessories

Clevis foot CRLBN

Material:
High-alloy steel

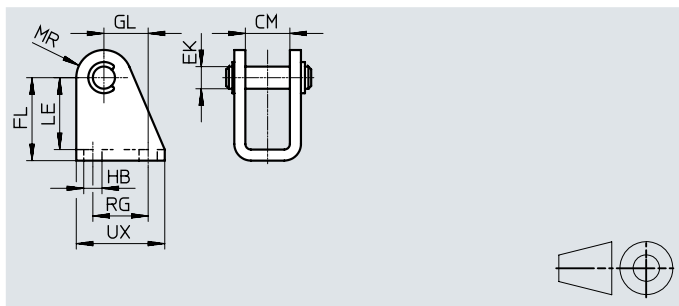
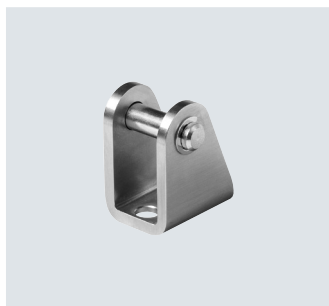

Dimensions and ordering data

For \varnothing	CM	EK \varnothing	FL	GL	HB	LE	MR	RG	UX	CRC ¹⁾	Weight [g]	Part no.	Type
12, 16	12.1	6	27 +0.3/-0.2	13	5.5	24	7	15	25	4	39	161862	CRLBN-12/16
20, 25	16.1	8	30 +0.4/-0.2	16	6.6	26	10	20	32	4	82	161863	CRLBN-20/25
32	16.1	10	35 +0.4/-0.2	18.5	6.6	31	11	24	35	4	106	195866	CRLBN-32
40	18.1	12	40 +0.4/-0.2	24.5	9	35	13	30	45	4	185	195867	CRLBN-40
50, 63	21.1	16	45 +0.5/-0.2	28	9	39	14	34	50	4	293	195868	CRLBN-50/63

1) More information: www.festo.com/x/topic/crc

Clevis foot LBG-...-R3

The pivot pin is secured against rotation with a spring pin.

Material: High-alloy stainless steel
RoHS-compliant

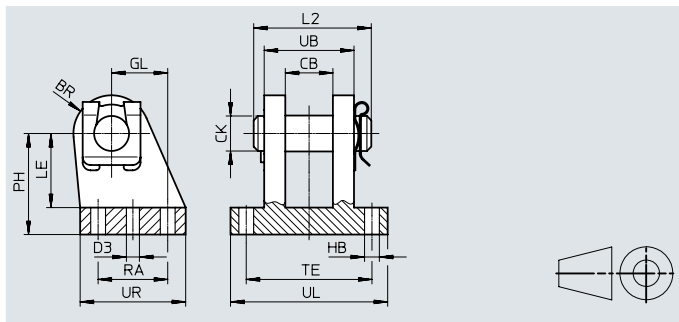
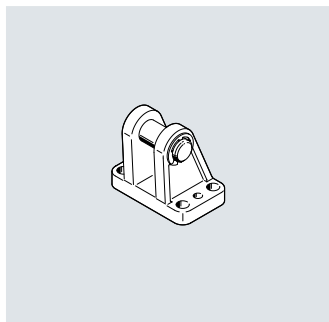

Dimensions and ordering data

For \varnothing	CL	CM	EK \varnothing	FL	GL	HB \varnothing	L2	LE	MR
80	50	25.1	20	63	30	11	60	49	18
100	50	25.1	20	71	41	11	60	56	22

For \varnothing	RF	RG	S1 \varnothing	UK	UX	CRC ¹⁾	Weight [g]	Part no.	Type
80	70	36	7.8	89	55	3	1050	2078797	LBG-80-R3
100	70	46	9.8	89	65	3	1375	2078799	LBG-100-R3

1) More information: www.festo.com/x/topic/crc

Accessories

Nut CR

Material:
High-alloy steel

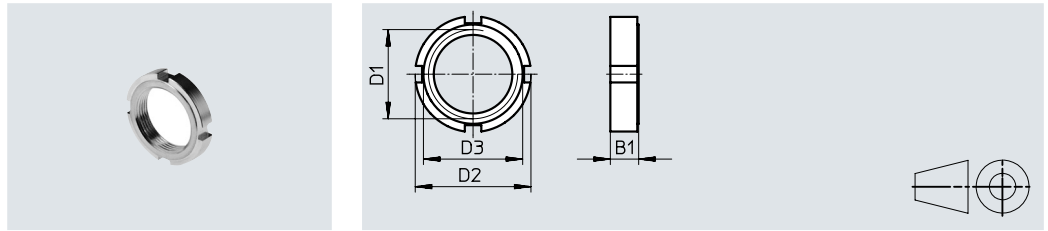

Dimensions and ordering data									
For \varnothing	B1	D1	D2	D3	CRC ¹⁾	Weight	Part no.	Type	
[mm]						[g]			
32	8	M30x1.5	42	36	4	40	197326	CR-M30x1.5	
40	10	M38x1.5	50	48	4	61	197327	CR-M38x1.5	
50, 63	10	M45x1.5	60	56	4	89	197328	CR-M45x1.5	
80, 100	13	M50x2	75	67	4	228	197329	CR-M50x2	

1) More information: www.festo.com/x/topic/crc

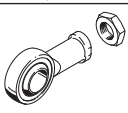
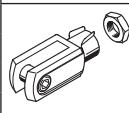
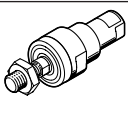
Ordering data – Piston-rod attachments, corrosion-resistant				Ordering data – Piston-rod attachments, corrosion-resistant			
	For \varnothing	Part No.	Type		For \varnothing	Part No.	Type
	12, 16	195580	CRSGS-M6		12, 16	13567	CRSG-M6
	20	195581	CRSGS-M8		20	13568	CRSG-M8
	25, 32	195582	CRSGS-M10x1.25		25, 32	13569	CRSG-M10x1.25
	40	195583	CRSGS-M12x1.25		40	13570	CRSG-M12x1.25
	50, 63	195584	CRSGS-M16x1.5		50, 63	13571	CRSG-M16x1.5
	80, 100	195585	CRSGS-M20x1.5		80, 100	13572	CRSG-M20x1.5
Self-aligning rod coupler CRFK							
	25, 32	2305778	CRFK-M10x1.25				
	40	2305779	CRFK-M12x1.25				
	50, 63	2490673	CRFK-M16x1.5				
	80, 100	2545677	CRFK-M20x1.5				

Datasheets → Internet: piston rod attachment

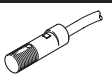
Ordering data – Proximity switches, magnetic reed CRSMEO				Ordering data – Proximity switches, magnetic reed CRSMEO	
	Electrical connection	Cable length	Part no.	Type	
	Cable	[m]			
	N/O				
	Corrosion-resistant				
	3-core	2.5	161775	CRSMEO-4-K-LED-24	

Datasheets → Internet: crsmeo

Ordering data – Mounting kits				Ordering data – Mounting kits	
	For \varnothing	Part no.	Type		
Mounting kit CRSMBR					
	12	164581	CRSMBR-12		
	16	164582	CRSMBR-16		
	20	164583	CRSMBR-20		
	25	164584	CRSMBR-25		
	32	163888	CRSMBR-32		
	40	163889	CRSMBR-40		
	50	163890	CRSMBR-50		
	63	163891	CRSMBR-63		

Datasheets → Internet: crsmbR

Accessories

Ordering data – Proximity switches CRSMT-8M for T-slot, magneto-resistive

Datasheets → Internet: crsmt

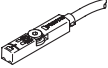
	Type of mounting	Switching output	Electrical connection	Cable length [m]	Part no.	Type
N/O contact						
	Inserted in the slot from above, flush with the cylinder profile	PNP	Cable, 3-core	5.0	574380	CRSMT-8M-PS-24V-K-5.0-OE
			Cable, 3-core	10.0	574381	CRSMT-8M-PS-24V-K-10.0-OE
			Plug M8x1, 3-pin	0.3	574383	CRSMT-8M-PS-24V-K-0.3-M8D
			Plug M12x1, 3-pin	0.3	574382	CRSMT-8M-PS-24V-K-0.3-M12

Connecting cables NEBA, straight, M8 connection

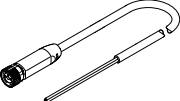
	Electrical connection 1, connection technology	Electrical connection 2, connection technology	Electrical connection 2, number of pins/cores	Cable length	Part no.	Type
	M8x1 A-coded to EN 61076-2-104	Open end	3	2.5 m	8078223	NEBA-M8G3-U-2.5-N-LE3
				5 m	8078224	NEBA-M8G3-U-5-N-LE3

Connecting cables NEBA, straight, M12 connection

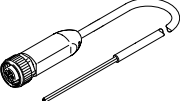
	Electrical connection 1, connection technology	Electrical connection 2, connection technology	Electrical connection 2, number of pins/cores	Cable length	Part no.	Type
	M12x1 A-coded to EN61076-2-101	Open end	3	2.5 m	8078236	NEBA-M12G5-U-2.5-N-LE3
				5 m	8078237	NEBA-M12G5-U-5-N-LE3

Connecting cables NEBA, angled, M8 connection

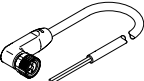
	Electrical connection 1, connection technology	Electrical connection 2, connection technology	Electrical connection 2, number of pins/cores	Cable length	Part no.	Type
	M8x1 A-coded to EN 61076-2-104	Open end	3	2.5 m	8078230	NEBA-M8W3-U-2.5-N-LE3
				5 m	8078231	NEBA-M8W3-U-5-N-LE3

Connecting cables NEBA, angled, M12 connection

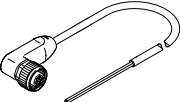
	Electrical connection 1, connection technology	Electrical connection 2, connection technology	Electrical connection 2, number of pins/cores	Cable length	Part no.	Type
	M12x1 A-coded to EN61076-2-101	Open end	3	2.5 m	8078245	NEBA-M12W5-U-2.5-N-LE3
				5 m	8078246	NEBA-M12W5-U-5-N-LE3

Accessories

Ordering data – Mounting kit SMBR		Part no.		Type	Datasheets → Internet: smbr
	For standards-based cylinder CRDSNU	538937	SMBR-8-8/100-S6		

Ordering data – One-way flow control valves CRGRLA			Part no.		Type	Datasheets → Internet: crgla
Connection Thread	For push-in fitting	Material				
	M5	CRQS/CRQSL/CRQST	Electropolished stainless-steel casting	161403	CRGRLA-M5-B	
	G1/8			161404	CRGRLA-1/8-B	
	G1/4			161405	CRGRLA-1/4-B	
	G3/8			161406	CRGRLA-3/8-B	
	G1/2			161407	CRGRLA-1/2-B	

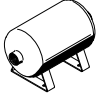
Ordering data – Air reservoirs CRVZS			Part no.		Type	Datasheets → Internet: crvzs
Connection Thread	Volume [l]	Material				
	G1/8	High-alloy stainless steel	160233	CRVZS-0.1		
	G1/4		160234	CRVZS-0.4		
	G1/4		160235	CRVZS-0.75		
	G1/2		160236	CRVZS-2		
	G1, G3/8		192159	CRVZS-5		
	G1, G3/8		160237	CRVZS-10		

Ordering data – Tubing		Part no.	Type	Datasheets → Internet: tubing
	Standard O.D. tubing	PLN, PFAN		