

**Back to Table of Contents**

**SK 19**  
**SK 26**

**A 8**  
**B 7**  
**C 8**  
**D 10**

**KAESER COMPRESSORS, Inc.**

511 Sigma Drive • P.O. Box 946 • Fredericksburg, Virginia 22 404  
Tel. (540) 898-5500 • Fax (540) 898-5520

# I N D E X

Page  
1

Section 1:	INDRODUCTION		
	1. Foreword		2
	2. Description		2
	3. To order parts		2
	4. Recommended spare parts list		2
	5. Caution		2
Section 2:	PARTS LIST	Code/Drawing No.	
	Frame, casing	A8	3
	Drawing system	B7	4
	Oil tubes, vent lines	C8	5
	Control tubes, compressed air tubes	D10 10	6
	Inlet valve	4.8595.5	7
	Combined discharge control valve	4.4579.1	8
	Combination valve	4.8690.1	9
	Minimum pressure check valve	4.7334.0	10
Section 3:	Recommended spare parts list		11-14

## SECTION 1

## I N T R O D U C T I O N

## 1. FOREWORD

This manual is provided for the operator's use and reference when ordering parts. An illustrated parts breakdown is included for identification. All compressor parts meet the manufacturer's highest quality used in the manufacture of the original equipment.

## 2. DESCRIPTION

The parts breakdown lists every part, assembly and sub-assembly of the compressor unit. Each part is identified with a number. The location of and relationship between parts are clearly illustrated. Questions pertaining to the number, description and quantities needed for each assembly are dealt with in the following pages.

## 3. TO ORDER PARTS

When ordering parts, furnish the following information to prevent any error:

- Model designation and serial number of the unit as shown on compressor nameplate.
- Reference number, part number, description and quantity required as listed.

## 4. RECOMMENDED SPARE PARTS LIST

A recommended spare parts list is provided at the end of this manual. The list indicates the description, part number, the quantity used in the compressor, and minimum quantities which should be carried to ensure maximum protection of the compressor. The recommended spare parts inventory to be kept on hand varies according to the location of the nearest distributor, and is broken down as follows:

- A. Local distributor
- B. Nearby distributor
- C. Remote distributor.

## 5. CAUTION

NEVER use parts other than the ones approved by the manufacturer and listed in this parts manual. The use of parts not approved by the manufacturer may result in hazardous conditions, over which the manufacturer has no control, bodily injury, and damage to the compressor unit. Such action would invalidate the manufacturer's warranty of the compressor unit.

Frame, Casing  
SK 19/26 type

**KAESER**  
COMPRESSORS

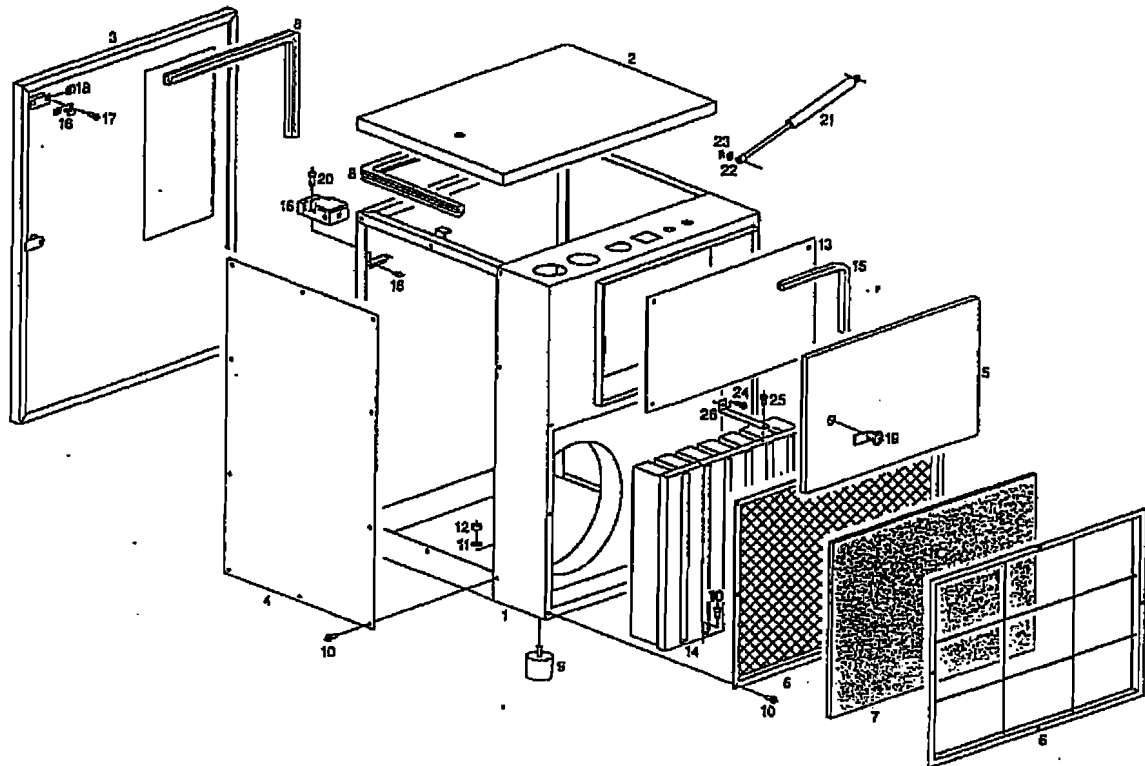

Ref.	Qty.	Part-No.	Description
1	1	2.7927.2	Frame
2	1	2.7940.1	Door
3	1	2.8024.1	Door
4	1	2.7941.0	Casing
5	1	202891.0	Door
6	1	6.1937.0	Change frame
7	1	6.1943.0	Filter mat
8	1	5.1398.0	Gasket profile 234 1/4"
9	4	6.1340.0	Rubber buffer dia. 50 x 43
10	19	6.2965.0	Phillips head screw M 4 x 10
11	4	6.0624.0	Washer
12	4	6.0885.0	Hex. nut M 10
13	1		Mounting plate
14	1	200046.0	Air inlet stencil
15	1	9.1554.0	Gasket profile 59"
16	2	7.2470.0	Door interlock switch
17	4	6.0916.0	Phillips head screw M 5 x 10
18	8	6.3118.0	Terminal clamp
19	1	6.2966.0	Fastener
20	4	6.3117.0	Phillips head screw M 5 x 25
21	1	5.1331.0	Gas spring
22	2	6.0623.0	Washer
23	2	5.1330.0	Split pin
24	2	6.3691.0	Phillips head screw M 6 x 12
25	2	6.2692.0	Sheet metal screw 3.5 x 9.5
26	2	200050.0	Support

Driving system  
SK 19/26 type

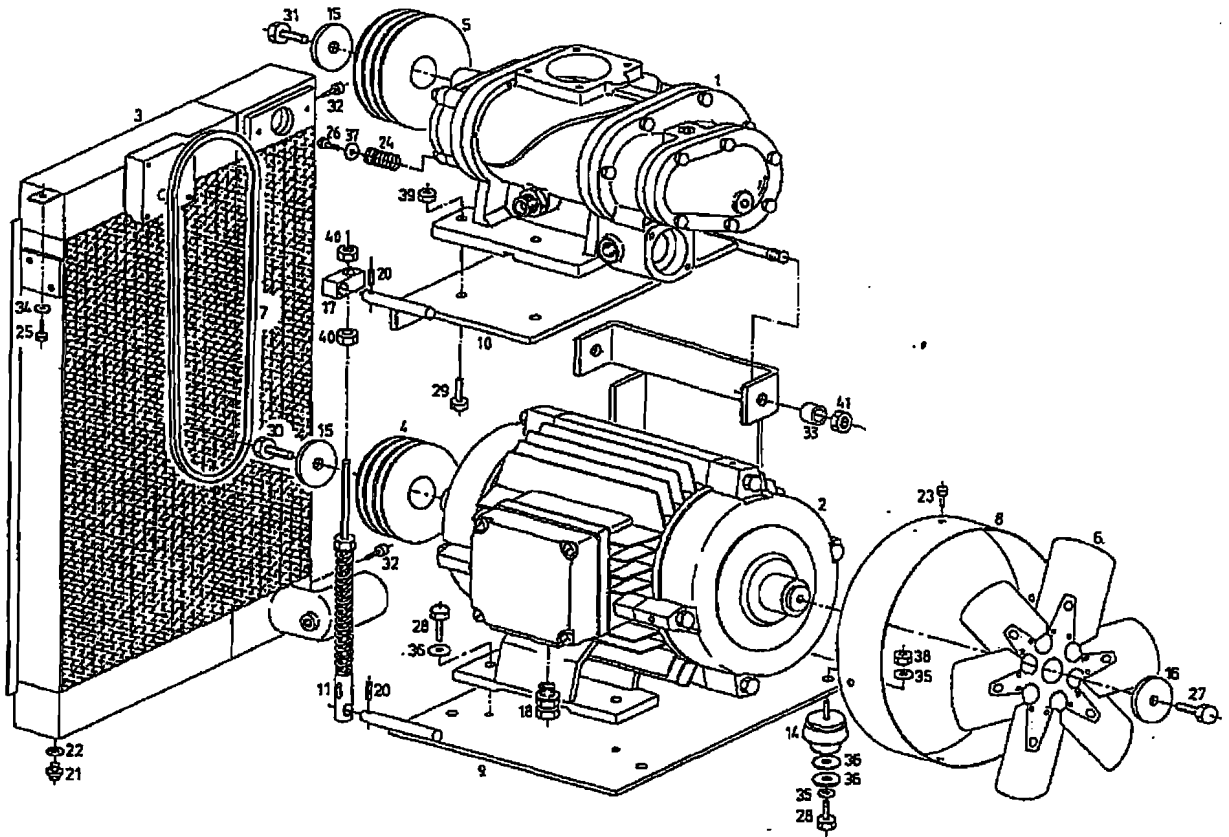

1.9760.20030 - 1.9765.20030

Ref.	Qty.	Part No.	Description
1	1	1.7147.1	Screw compressor Sigma 12
1-3) 2	1	7.2180.0	Motor, 3-phase 11 kW
4-6) 2	1	7.2183.0	Motor, 3-phase 15 kW
3	1	5.1026.00010	Cooler
1-2) 4	1	2.8144.0	Motor pulley dia. 3 7/8"
3) 4	1	2.8302.0	Motor pulley dia. 3 1/2"
4-6) 4	1	2.8300.0	Motor pulley dia. 5 1/8"
1) 5	1	4.4727.0	Compressor pulley dia. 5 5/8"
2) 5	1	2.8301.0	Compressor pulley dia. 6 1/2"
3) 5	1	2.8303.0	Compressor pulley dia. 7 1/8"
4) 5	1	4.4719.0	Compressor pulley dia. 5 3/8"
5) 5	1	2.6777.0	Compressor pulley dia. 6"
6) 5	1	2.8293.0	Compressor pulley dia. 7 1/8"
6	1	5.0682.0	Fan wheel dia. 11"
1) 7	1	6.2512.0	Set of v-belts
2) 7	1	6.2513.0	Set of v-belts
3) 7	1	6.2513.0	Set of v-belts
4) 7	1	6.2513.0	Set of v-belts
5) 7	1	6.2514.0	Set of v-belts
6) 7	1	6.2516.0	Set of v-belts
1-3) 8	1	4.7741.00010	Ring
4-6) 8	1	4.7741.0	Ring
9	1	200114.0	Swing frame
10	1	200116.0	Whip
11	1	4.7949.0	Balance adjustment
14	4	6.1328.0	Base of the machine
15	2	4.3848.0	Disk
16	1	5.0427.0	Disk
17	1	200118.0	Support
18	2	7.0644.0	Cable fitting PG 21
18	2	7.0645.0	Cable fitting PG 29
20	3	6.0604.0	Clamping sleeve dia. 4 x 20
21	1	6.0500.0	Locking screw G 1/4
22	1	6.0432.0	Gasket G 1/4

Ref.	Qty.	Part No.	Description
23	2	6.2216.0	Hex.-head screw M 6 x 8
24	1	5.1663.0	Compression spring
25	1	6.0720.0	Hex.-head screw M 6 x 15
26	1	6.0725.0	Hex.-head screw M 8 x 15
27	1	6.0761.0	Hex.-head screw M 10 x 20
28	8	6.0763.0	Hex.-head screw M 10 x 30
29	4	6.0768.0	Hex.-head screw M 12 x 40
30	1	6.2259.0	Hex.-head screw M 14x1.5x40
31	1	6.2260.0	Hex.-head screw M 14x1.5x40
32	2	6.2426.0	Cylinder screw with inside hex M 6 x 20
33	1	2.8089.0	Sleeve
34	1	6.2372.0	Washer
35	8	6.0624.0	Washer
36	12	6.2373.0	Washer
37	2	6.0631.0	Washer
38	4	6.0685.0	Hex. nut M 10
39	4	6.0686.0	Hex. nut M 12
40	2	6.0688.0	Hex. nut M 16
41	1	6.3013.0	Hex. nut M 16
1) Compressor			Unit SK 19/110 psig
2) Compressor			Unit SK 19/145 psig
3) Compressor			Unit SK 19/190 psig
4) Compressor			Unit SK 26/110 psig
5) Compressor			Unit SK 26/145 psig
6) Compressor			Unit SK 26/190 psig

Oil tubes,  
Vent lines  
SK 19/26 type

**KAESER  
COMPRESSORS**

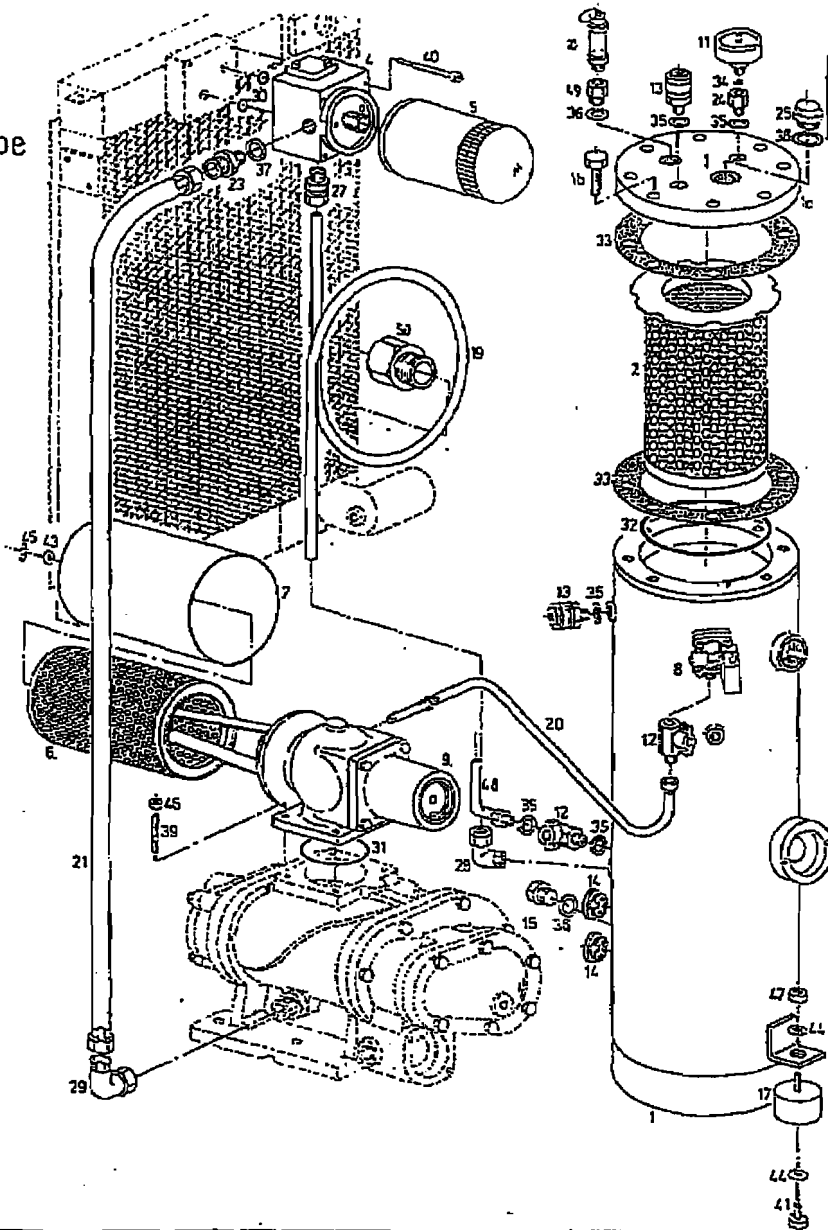

Ref.	Qty.	Part No.	Description
1	1	3.6127.2	Oil separator tank 5.5 gal
1a	1	2.8446.0	Cover
1b	8	6.2210.0	Hex.-head screw M 14 x 40
2	1	6.1931.1	Oil separator cartridge
4	1	4.8690.1	Combination valve
5	1	6.1585.0	Filter cartridge
6	1	6.2003.0	Filter cartridge
7	1	5.0973.2	Casing
8	1	4.4579.1	Combined discharge/auxiliary valve
9	1	4.8595.4	Inlet valve
2)	10	8.2054.1	Safety valve 1/4 NPT 130 psig
3)	10	8.2056.0	Safety valve 1/4 NPT 165 psig
4)	10	8.2070.0	Safety valve 1/4 NPT 210 psig
5)	10	8.2054.0	Safety valve 1/4 NPT 130 psig
6)	10	8.2066.0	Safety valve 1/4 NPT 165 psig
7)	10	8.2070.0	Safety valve 1/4 NPT 210 psig
11	1	8.0017.0	Pressure gauge G 1/4, 0-360/215 psig
12	2	8.0240.0	Ball cock G 1/4
13	2	9.0843.1	Hose coupling G 1/4
14	2	6.0105.0	Oil sight glass G 3/4
15	1	6.0501.0	Locking screw G 3/8
17	2	6.1334.0	Rubber buffer dia. 50 x 45
19	1	4.3862.0	Tube
20	1	8.1947.0	Hose line dia. 1/4" x 13 3/4"
21	1	8.1220.0	Hose line dia. 1/2" x 26 3/8"
23	1	5.0783.0	Double nipple G 1/2 x G 3/8
24	1	5.0876.0	Pressure gauge nipple G 1/4
25	1	6.2619.0	Locking screw G 3/4
27	1	6.0236.0	Pipe fitting R 3/8
28	1	6.0256.0	Angle fitting R 3/8
29	1	6.0286.0	Angle fitting
31	1	5.1491.0	O-ring dia. 74 x 3

Ref.	Qty.	Part No.	Description
32	1	5.1563.0	O-ring dia. 135 x 5
33	2	5.0474.1	Gasket
34	1	6.0470.0	Gasket for pressure gauge G 1/4
35	5	6.0432.0	Gasket G 1/4
36	2	6.0435.0	Gasket G 3/8
37	1	6.1521.0	Gasket G 3/8
38	1	6.0441.0	Gasket G 3/4
39	4	6.2350.0	Stud M 8 x 20
40	4	6.2902.0	Cylinder screw with inside hex. M 6 x 70
41	2	6.2213.0	Hex.-head screw M 10 x 14
43	1	6.0622.0	Washer
44	4	6.0624.0	Washer
45	1	6.2951.0	Thumb nut M 6
46	4	6.0684.0	Hex. nut M 8
47	2	6.0685.0	Hex. nut M 10
48	1	8.1259.0	Hose line DN 9 x 600
49	1	6.3201.0	Reducing socket 1/2 x 1/4 NPT
50	1	4.4444.0	Adapter G 1 x 1 NPT

Parts 2/32/33 are included in the complete oil separating cartridge set No. 6.2008.0

1) dependent upon the type

2) Compressor Unit 110 psig  
3) Compressor Unit 145 psig  
4) Compressor Unit 190 psig

Control tubes,  
compressed air tubes  
SK 19/26 type

**KAESER**  
COMPRESSORS

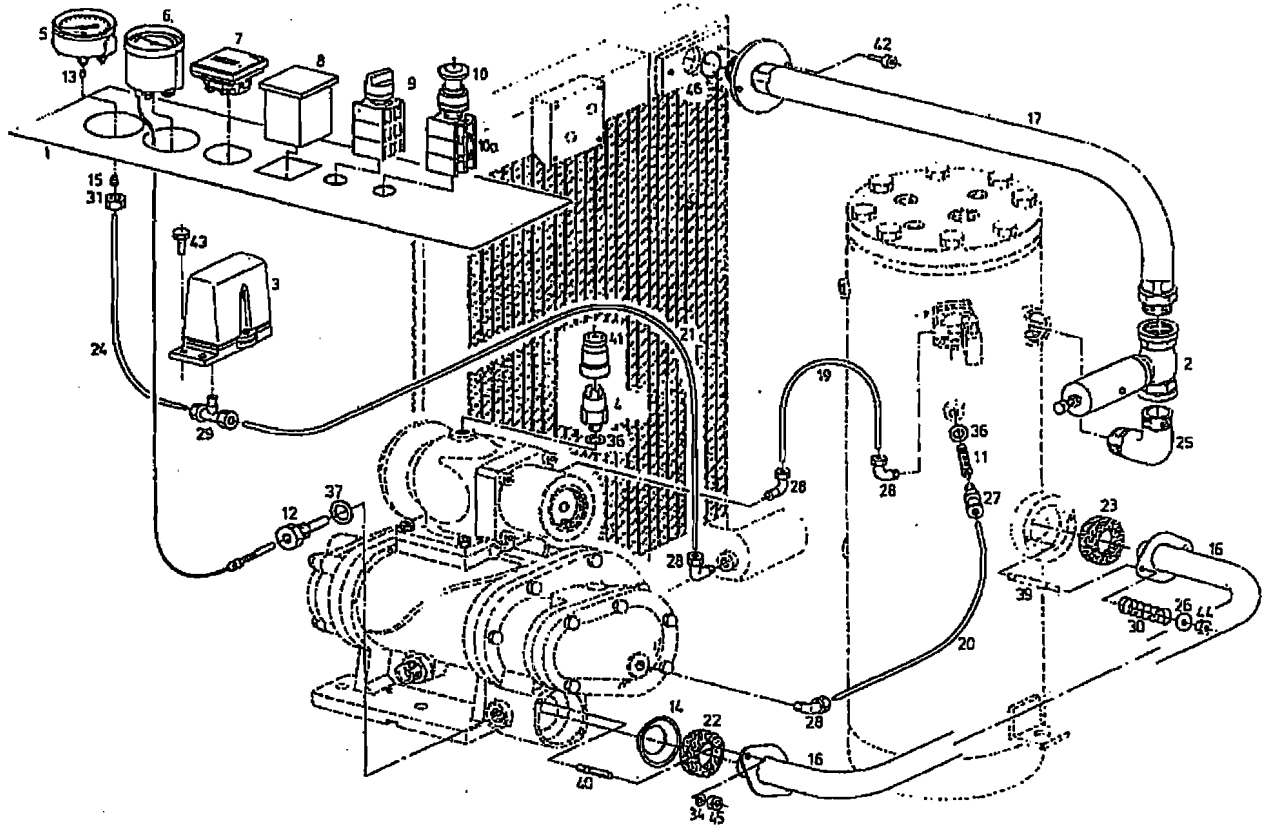

Ref.	Qty.	Part-No.	Description
1	1	5.2289.1	Foil label
2	1	4.7334.0	Minimum pressure check valve G 1
1) 3	1	7.2973.0	Pressure switch 116 psig
2,3) 3	1	7.2974.0	Pressure switch 232 psig
4	1	7.1422.0	Pressure switch 14,5 psig
1) 5	1	8.0153.0	Pressure gauge 0-145/110 psig
2) 6	1	8.0136.0	Pressure gauge 0-232/145 psig
3) 5	1	8.0138.0	Pressure gauge 0-232/190 psig
8	1	8.0197.0	Distance thermometer
7	1	7.0784.0	Hour meter
8	1	7.1082.00020	Malfunction relay
9	1	7.2778.1	Switch
10	1	7.3629.0	Emergency stop button
10a	1	7.3630.0	Contact
11	1	6.1143.1	Strainer
12	1	6.0929.0	Protection sleeve G 3/8
13	1	8.0165.0	Nozzle
14	1	5.7042.0	Disc
15	1	6.0353.00010	Stuffing cone
15	1	4.4580.1	Tube
17	1	8.1221.0	Hose line dia. 1" x 17 3/8"
19	1	2.8785.0	Control tube dia. 1/4" x 13 1/2"
20	1	9.0616.0	Control tube dia. 1/4" x 12 1/4"
21	1	201322.0	Control tube dia. 1/4" x 35 1/2"
22	1	5.2756.0	Gasket ring
23	1	5.2757.0	Gasket ring
24	1	2.8754.0	Control tube dia. 1/4" x 18 1/2"
26	1	6.1093.0	Angle R 1
26	2	6.0622.0	Washer
27	1	4.3873.0	Pipe fitting G 1/4
28	4	6.0266.0	Angle fitting R 1/8
29	1	6.0344.0	T pipe fitting R 1/8
30	2	5.1671.0	Compression spring
31	1	6.0373.0	Screw Cap
34	2	6.0623.0	Washer
36	2	6.0432.0	Gasket G 1/4

Ref.	Qty.	Part-No.	Description
37	1	6.1621.0	Gasket G 3/8
39	2	6.2398.1	Stud M 6 x 54,5
40	2	6.2350.0	Stud M 8 x 20
41	1	7.1505.0	Rubber cap
42	2	6.0790.0	Cylinder screw with inside hex. M 6 x 15
43	2	6.0721.0	Hex. head screw M 6 x 20
44	2	6.2430.0	Hex. nut M 6
45	2	6.2431.0	Hex. nut M 8
46	1	6.1567.0	O-ring dia. 24 x 3
			Part 11 is included in the complete oil separating cartridge set No. 6.2008.0
			1) Compressor Unit 110 psig
			2) Compressor Unit 145 psig
			3) Compressor Unit 190 psig

Inlet valve  
4.8595.4

**KAESER**  
COMPRESSORS

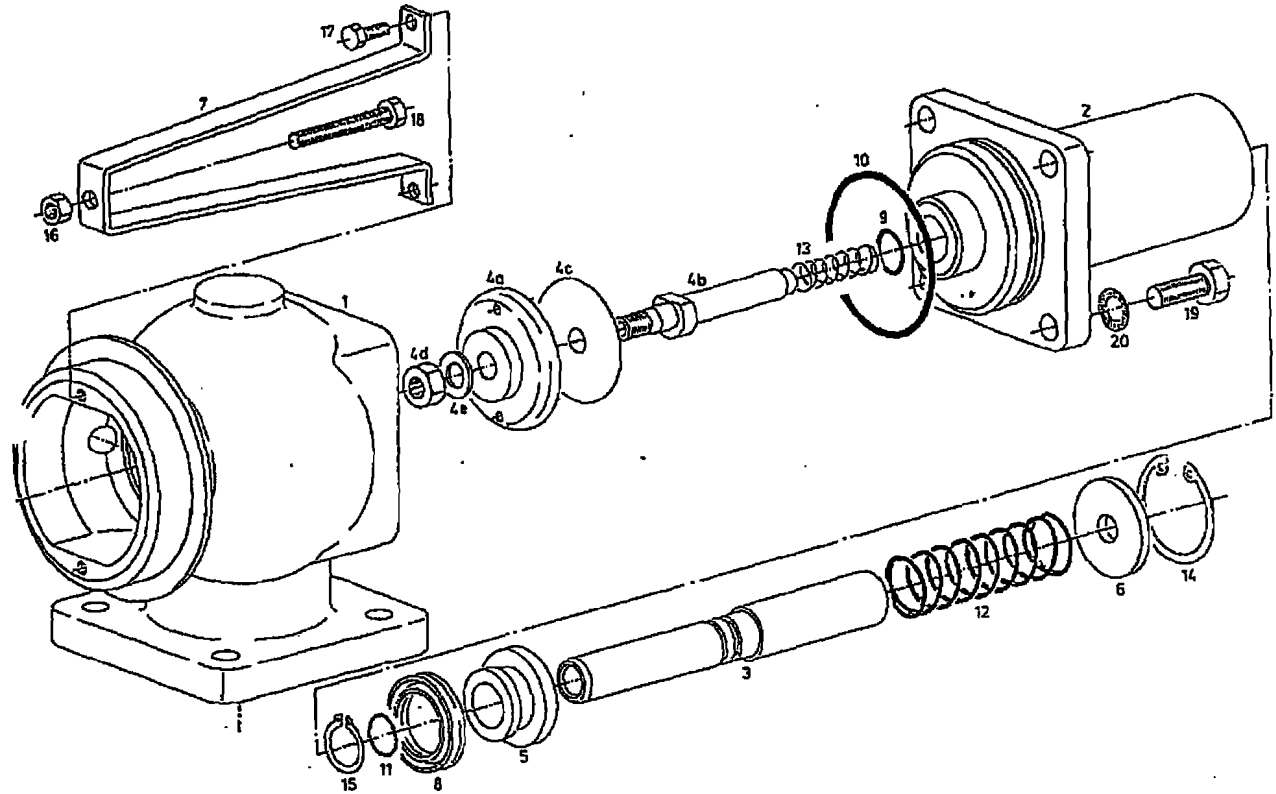

Ref.	Qty.	Part No.	Description
1	1	200487.0	Valve chamber
2	1	2.6267.0	Cylinder
3	1	200316.0	Piston
4	1	2.8294.1	Valve disk complete
4a	1	200319.0	Valve disk
4b	1	200318.0	Bolt
4c	1	2.5926.0	Lamina
4d	1	6.0684.0	Hex. nut M8
4e	1	6.2381.0	Washer
5	1	200317.0	Lip seal seat
6	1	6.3271.0	Washer
7	1	200516.0	Support for air filter
8	1	5.5014.1	Gasket for piston
9	1	5.1499.0	O-ring dia. 18 x 3
10	1	5.1500.0	O-ring dia. 63 x 2.5
11	1	5.1419.0	O-ring dia. 14 x 2
12	1	5.1408.0	Compression spring
13	1	5.1637.1	Compression spring
14	1	6.0554.0	Guard ring 42 x 1.75
15	1	6.2846.0	Guard ring 18 x 1.2
16	1	6.0682.0	Hex. nut M 6
17	2	6.0745.0	Hex.-head screw M 5 x 12
18	1	6.2293.0	Hex.-head screw M 6 x 40
19	4	6.0726.0	Hex.-head screw M 8 x 20
20	4	6.0672.0	Safety disk

Combined discharge  
control valve  
4.4579.1

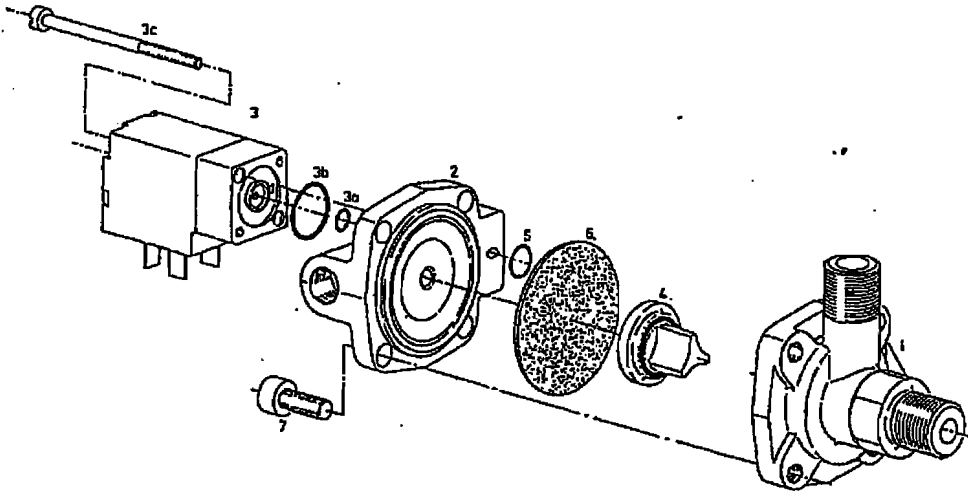

Ref.	Qty.	Part No.	Description
1	1	4.4582.0	Crankcase
2	1	4.4580.0	Cover
3	1	7.1384.1	Solenoid valve complete
3a	1	5.1586.0	O-ring dia. 3 x 1,5
3b	1	5.1536.0	O-ring dia. 12 x 1,5
3c	2	6.3110.0	Filister head screw M 3 x 45
4	1	4.9027.0	Piston complete
5	1	5.1582.0	O-ring dia. 6 x 1,25
6	1	5.1007.0	Diaphragm
7	4	6.2408.0	Cylinder screw with inside hex. M 5 x 12

4.4579.1

Combination valve  
4.8690.1

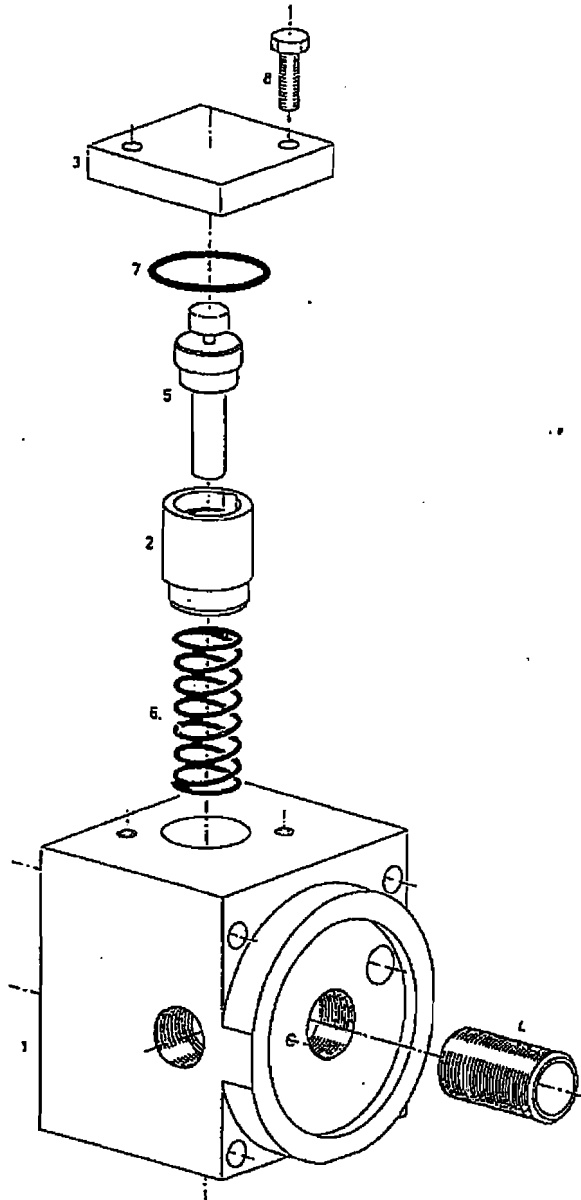

EL 4.8690.1-5/1

Ref.	Qty.	Part No.	Description
1	1	200361.0	Valve body
2	1	200359.0	Actuating piston
3	1	200360.0	Cover
4	1	5.1147.0	Thread nipple
5	1	7.2013.0	Working element
6	1	5.1615.0	Compression spring
7	1	5.1502.0	O-ring dia. 30 x 2
8	2	6.0721.0	Hex.-head screw M 6 x 20

Minimum pressure  
check valve  
4.7334.0

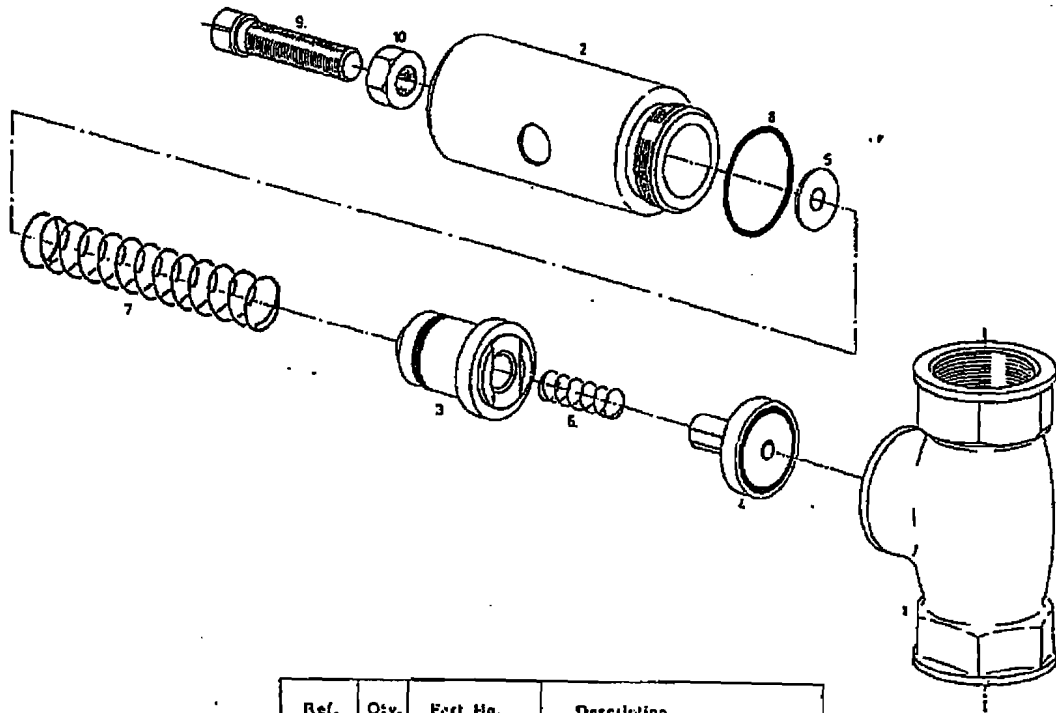

Ref.	Qty.	Part No.	Description
1	1	4.8571.0	Valve body G 1
2	1	4.8572.0	Cylinder
3	1	4.9024.0	Piston complete
4	1	4.9017.0	Valve disk complete
5	1	6.2370.0	Disk
6	1	5.0848.0	Compression spring
7	1	5.0647.0	Compression spring
8	1	5.1432.0	O-ring dia. 30 ± 2.5
9	1	6.0847.0	Square-head bolt M 8 x 30
10	1	6.0684.0	Hex. nut M 8

4.7334.0

## Section 1

## RECOMMENDED SPARE PARTS LIST

Model SK 19/26

DESCRIPTION	Part No.	Qty. per unit	LOCATION		Recommended Quantities		
			Section	Ref.	A	B	C
Oil filter cartridge	6.1985.0	1	Oil tubes, Vent lines	5	1	2	3
Oil separating cartridge complete set consists of	6.2008.1				1	1	2
Oil separator cartridge	6.1931.1	1	Oil tubes, Vent lines	2			
Gasket for tank	5.0474.1	2	Oil tubes, Vent lines	33			
O-ring dia. 140 x 50	5.1563.0	1	Oil tubes, Vent lines	32			
Silencer	5.1143.0	1	Control tubes, compressed air tubes	11			
V-belt set SK 19 110 psig	6.2512.0	1	Driving system	7	1	1	2
V-belt set SK 19 145 psig	6.2513.0	1	Driving system	7	1	1	2
V-belt set SK 19 190 psig	6.2513.0	1	Driving system	7	1	1	2
V-belt set SK 26 110 psig	6.2513.0	1	Driving system	7	1	1	2
V-belt set SK 26 145 psig	6.2514.0	1	Driving system	7	1	1	2
V-belt set SK 26 190 psig	6.2516.0	1	Driving system	7	1	1	2
Filter cartridge	6.2003.0	1	Oil tubes, Vent lines	6	2	3	4
Filter mat	6.1943.0	1	Frame, Casing	7	2	3	4
O-ring dia. 12 x 1.5	5.1539.0	1	Oil tubes, Vent lines	30	1	1	2
O-ring dia. 24 x 3	5.1567.0	1	Control tubes Compressed air tubes	46	1	1	2
O-ring dia. 50 x 2.5	5.1564.0	1	Control tubes	34	1	1	2
O-ring dia. 74 x 2	5.1563.0	1	Oil tubes, Vent lines	31	1	1	2
Gasket G 1/4	6.0470.0	1	Oil tubes, Vent lines	34	1	1	2
Gasket G 1/4	6.0432.0	5	Oil tubes, Vent lines	35	1	1	2
Gasket G 1/4	6.0432.0	2	Control tubes Compressed air tubes	36	1	1	2
Gasket G 3/8	6.0435.0	2	Oil tubes, Vent lines	36	1	1	2
Gasket G 3/8	6.1521.0	1	Oil tubes, Vent lines	37	1	1	2
Gasket G 3/8	6.1521.0	1	Control tubes Compressed air tubes	37	1	1	2
Gasket G 1/2	6.0438.0	2	Control tubes Compressed air tubes	38	1	1	2
Gasket G 3/4	6.0441.0	1	Oil tubes, Vent lines	38	1	1	2
Gasket ring	5.1398.1	2	Control tubes Compressed air tubes	22	1	1	2
Diaphragm	5.1007.0	1	Combined charge control valve	6	1	1	2

## Section 1

## RECOMMENDED SPARE PARTS LIST

Model SK 19/26

DESCRIPTION	Part No.	Qty per unit	LOCATION		Recommended Quantities		
			Section	Ref.	A	B	C
Pressure switch 115 psig	7.2973.0	1	Control tubes Compressed air tubes	3	0	1	1
Pressure switch 230 psig	7.2974.0	1	Control tubes Compressed air tubes	3	0	1	1
Pressure switch 145 psig	7.1422.0	1	Control tubes Compressed air tubes	4	0	1	1
Valve disk complete	2.8294.1	1	Inlet valve	4	1	1	2
Valve disk complete	4.9017.0	1	Minimum pressure check valve	4	1	1	2
Piston complete	4.9024.0	1	Minimum pressure check valve	3	1	1	2
Piston complete	4.9027.0	1	Combined discharge control valve	4	1	1	2
Compression spring	5.1637.0	1	Inlet valve	13	0	1	1
Compression spring	5.1608.0	1	Inlet valve	12	0	1	1
Compression spring	5.1615.0	1	Combination valve	6	0	1	1
Compression spring	5.0648.0	1	Minimum pressure check valve	6	0	1	1
Compression spring	5.0647.0	1	Minimum pressure check valve	7	0	0	1
Working element	7.2013.0	1	Combination valve	5	1	1	1
Inlet valve	4.8595.5	1	Oil tubes, Vent lines	9	0	0	1
Combined discharge control valve	4.4579.1	1	Oil tubes, Vent lines	8	0	0	1
Combination valve	4.8690.1	1	Oil tubes, Vent lines	8	0	0	1
Minimum pressure check valve	4.7334.0	1	Control tubes, Compressed air tubes	2	0	1	1