



EOSi PRESENTATION

Pamela Cateland



THE RANGE



Designation	Power (kW)
EOS 350i	5.5* kW
EOS 585i / EOS 350Qi	7.5 kW
EOS 730i / EOS 585Qi	11 kW
EOS 900i / EOS 730Qi	15 kW

Designation	Power (kW)
EOS 1300i	22 kW
EOS 1600i / EOS 1300Qi	30 kW
EOS 1900i / EOS 1600Qi	37 kW

EOS 350-900i



Hot / cool canopy

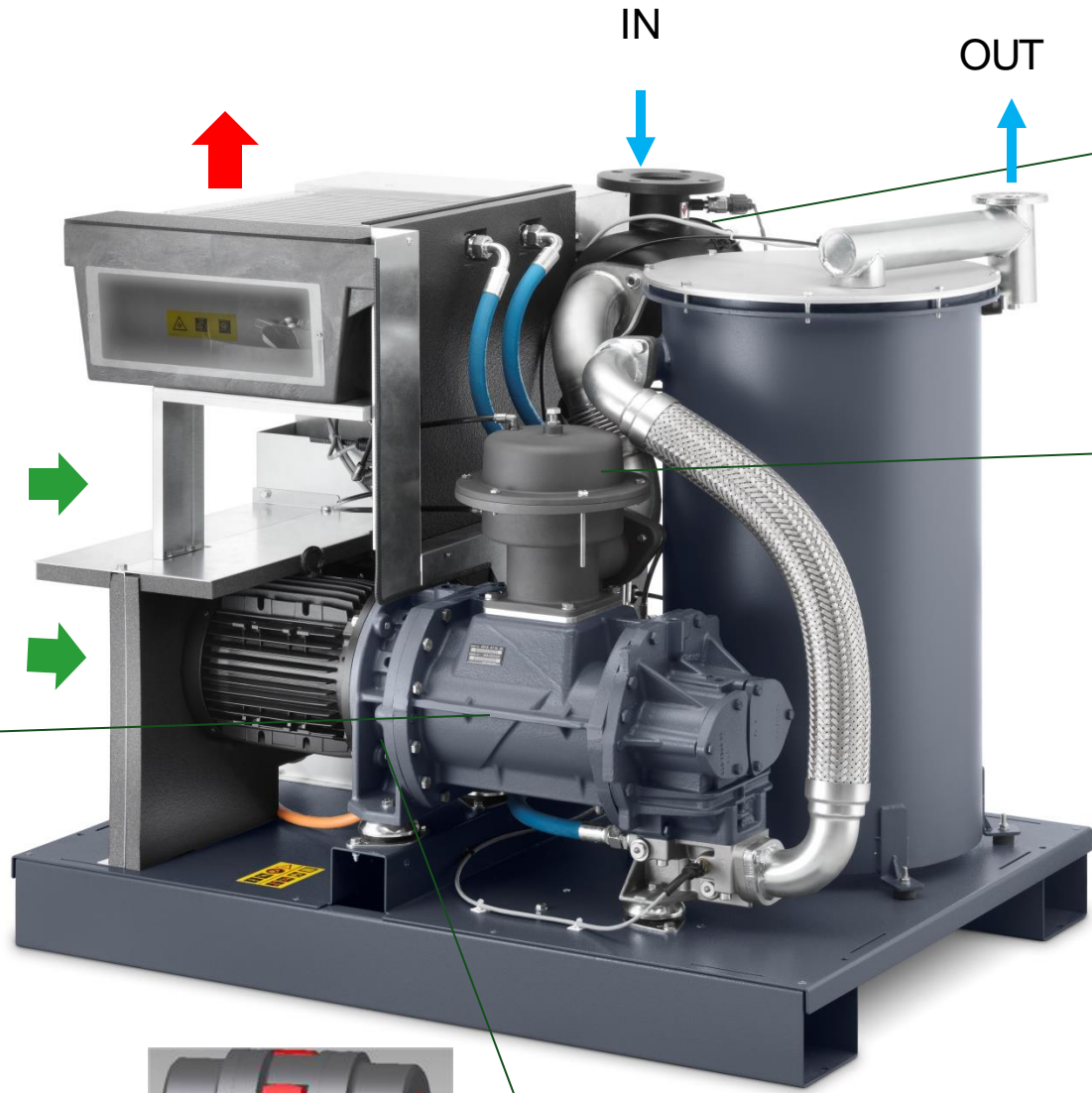

IN

OUT

Inlet filter

Inlet control valve

Screw element

Direct drive coupling



EOS 350-900i



EOS 350-900i

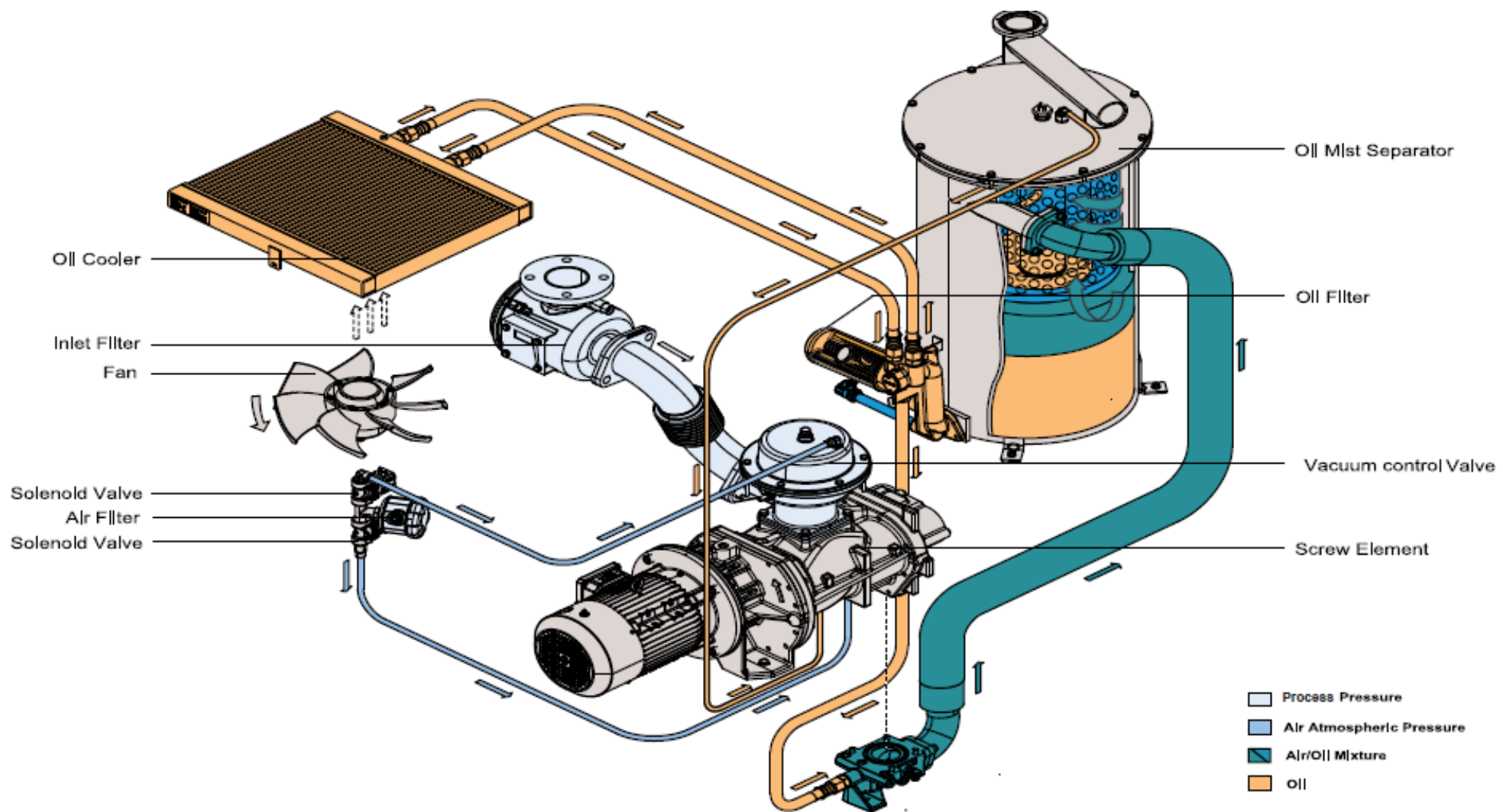

REGULATION

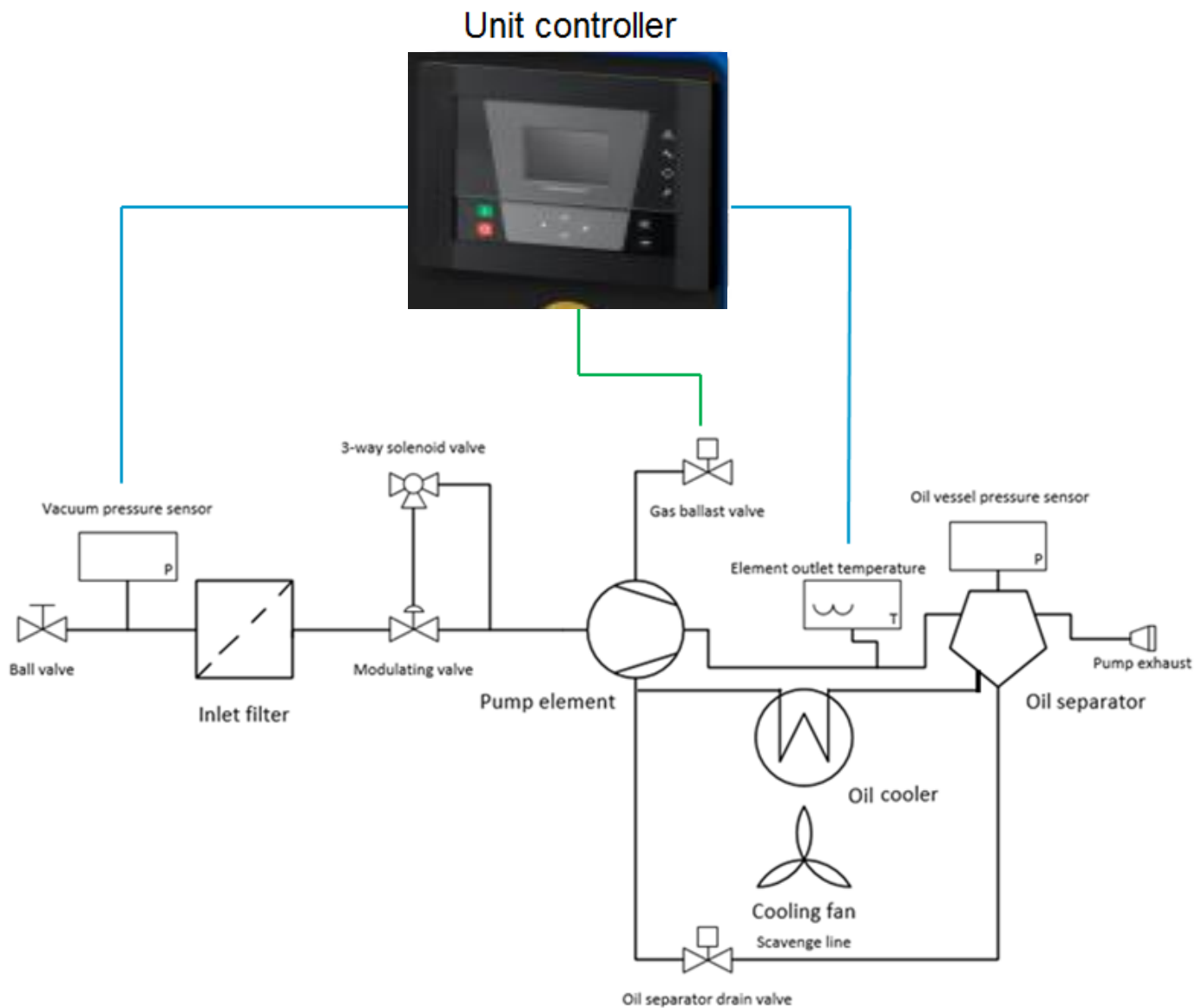

EOS 1300-1900i

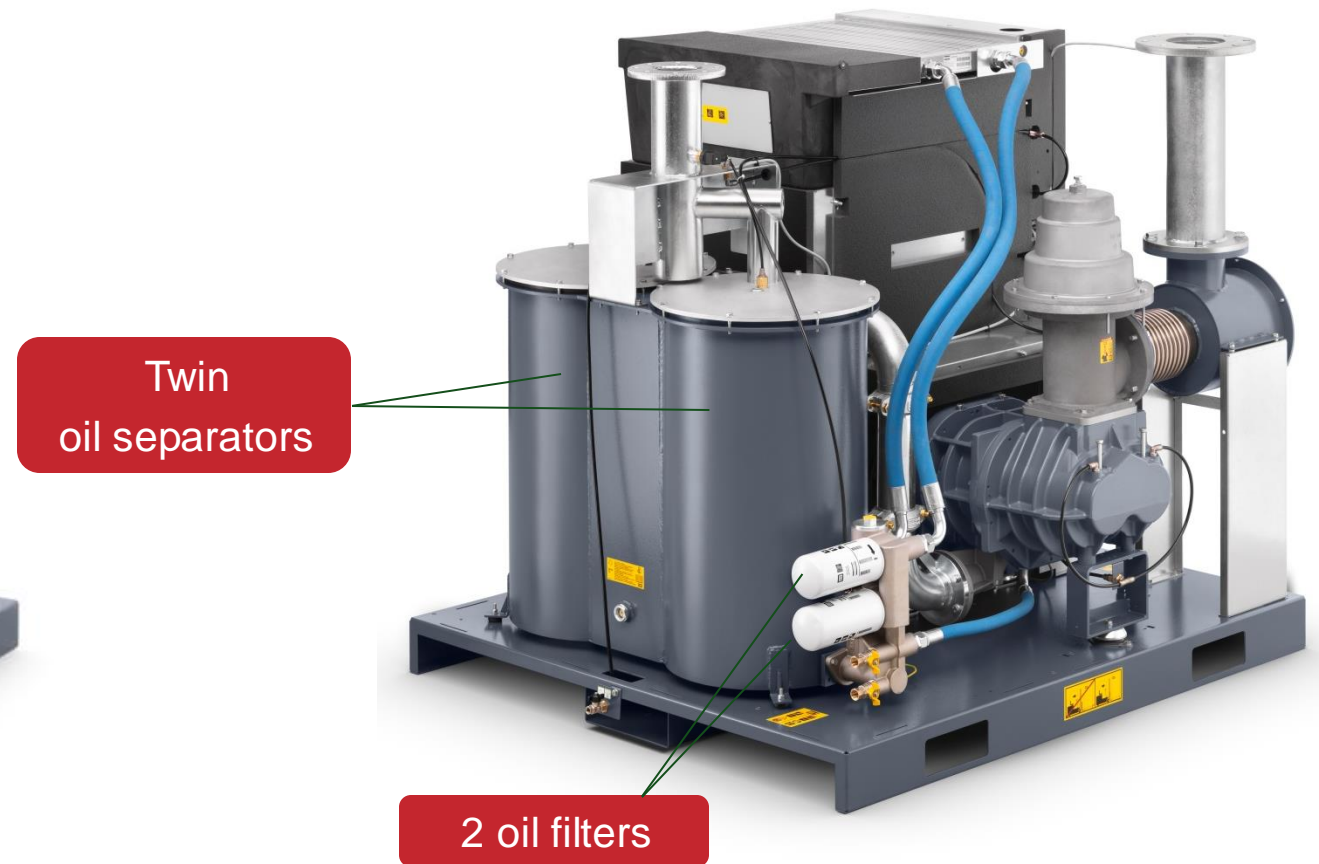
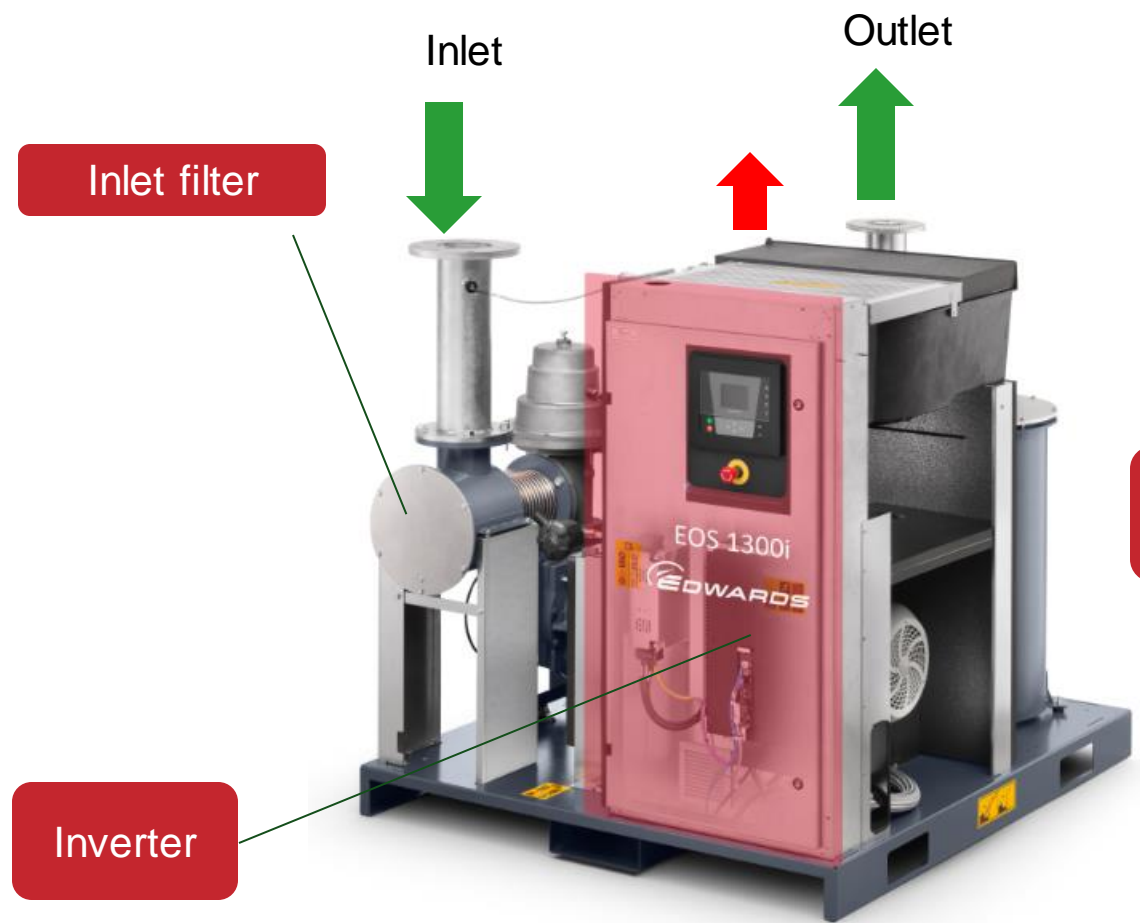

EOS 1300-1900i

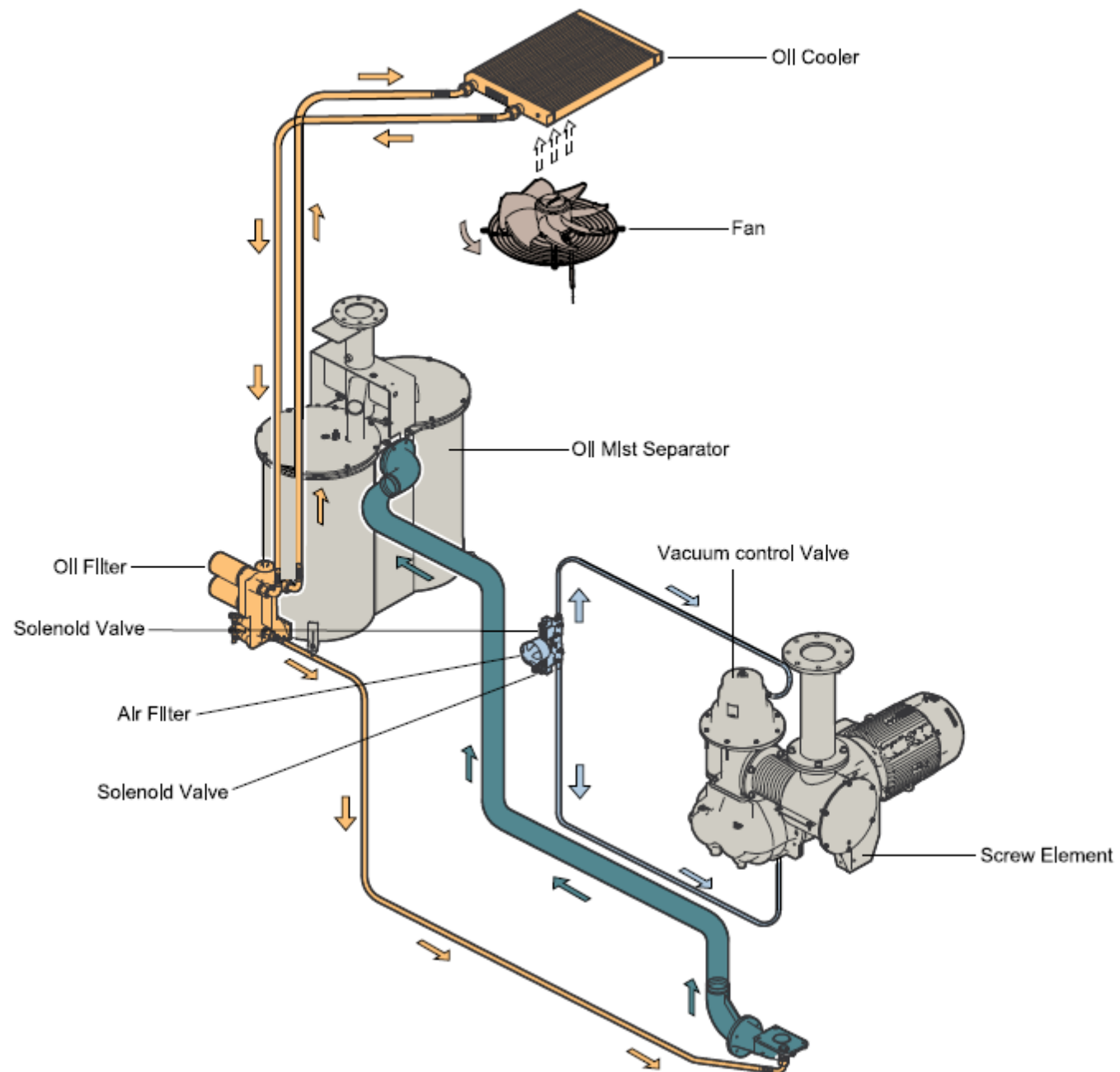



PERFORMANCES CURVES / AML

OIL SEALED ROTARY TECHNOLOGY FIXED SPEED

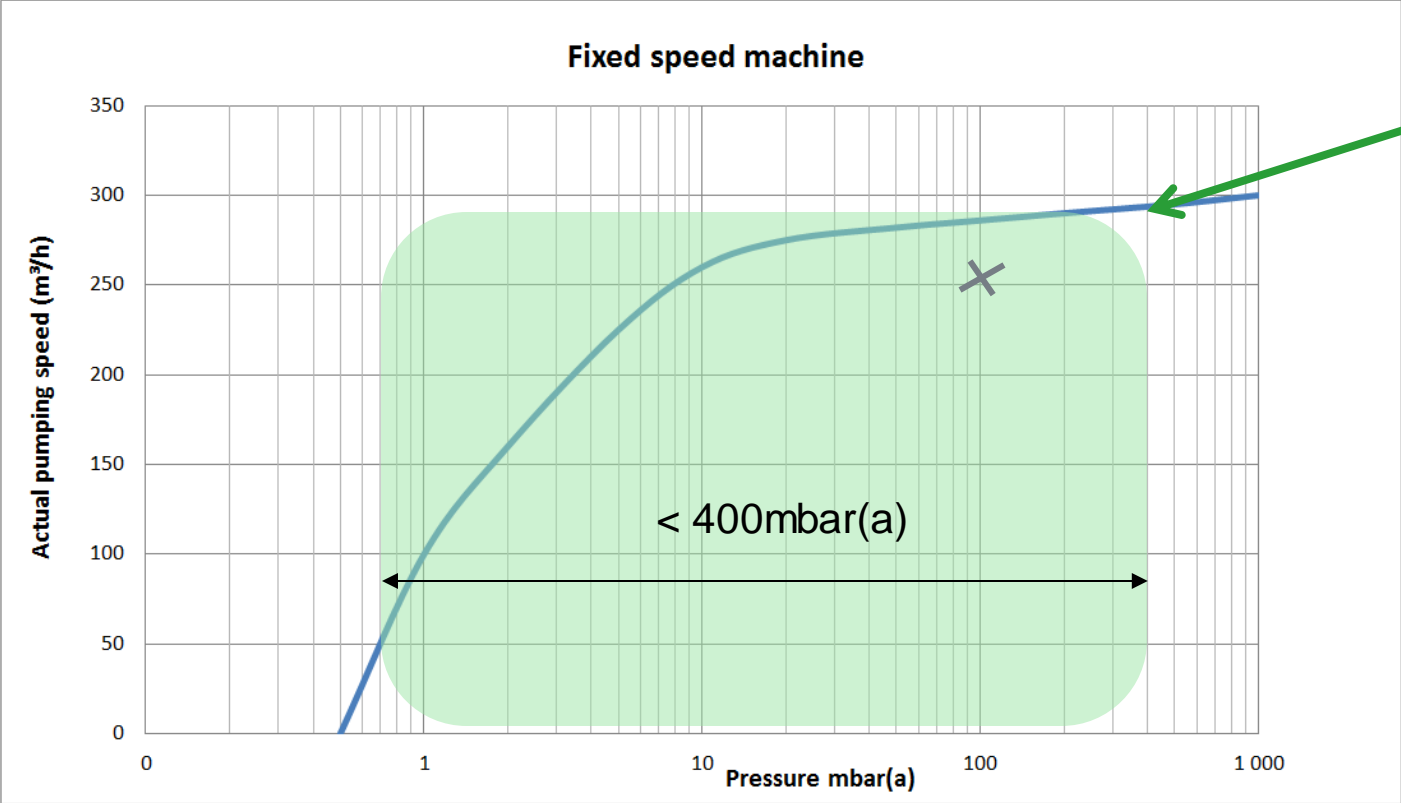

Only one pumping speed curve

Often oversized

What is the operating pressure band for what an oil sealed rotary technology have been designed for ?

EOSi CURVE

EOS900i

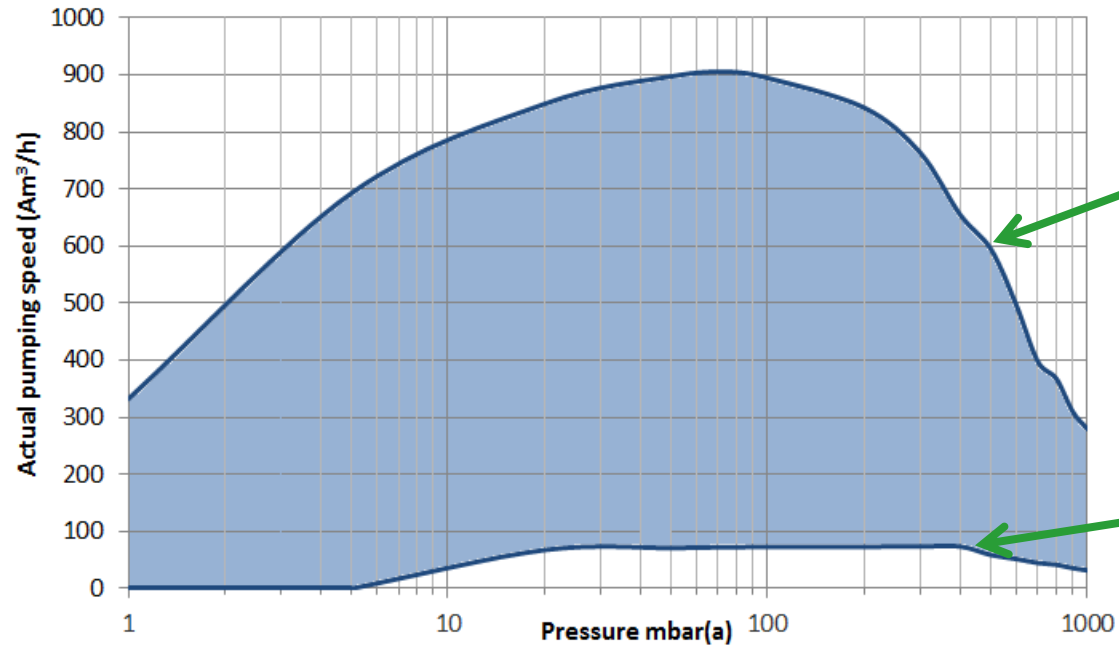

Maximum pumping speed curve

Minimum pumping speed curve

EOSi CURVE

EOS900i

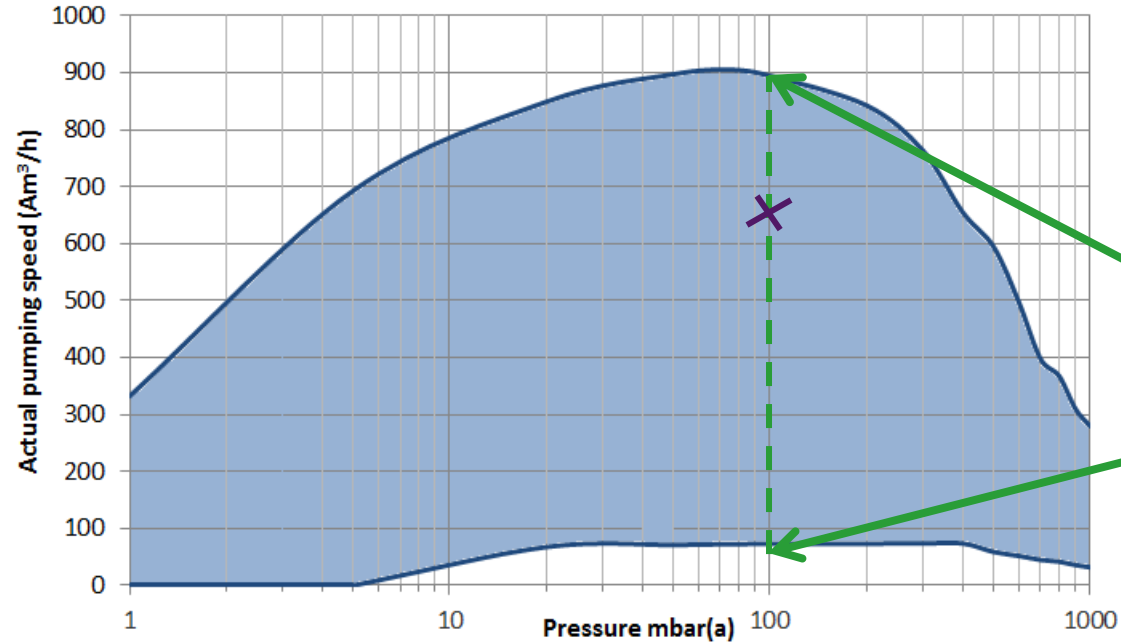

The rotor speed and the flow vary between the minimum and maximum to maintain the pressure set point.

➔ Match directly with the demand

EOSi CURVE

EOS900i

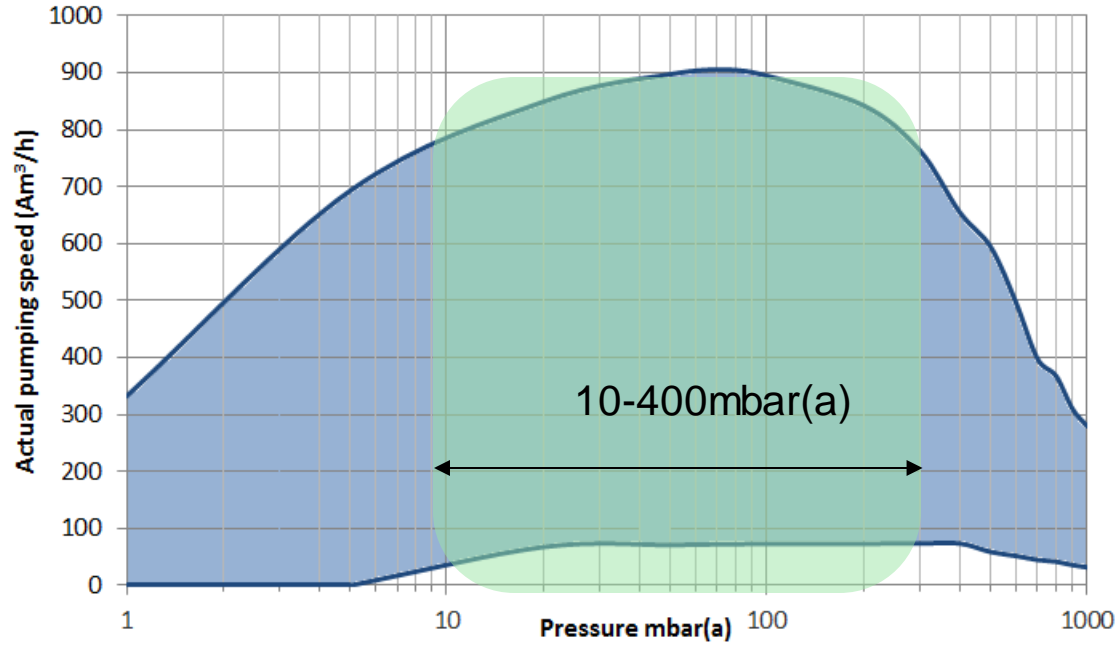

Designed operating range 10-400mbar(a)
-> great performances

EOS VS OIV

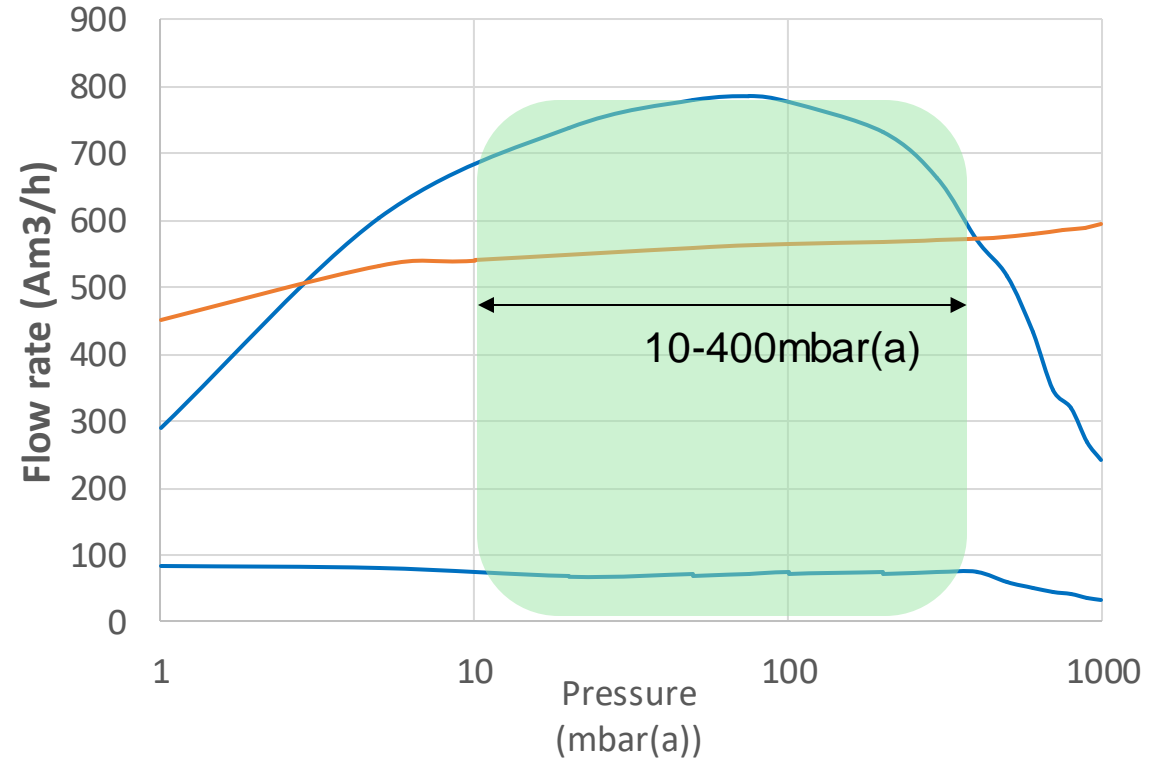
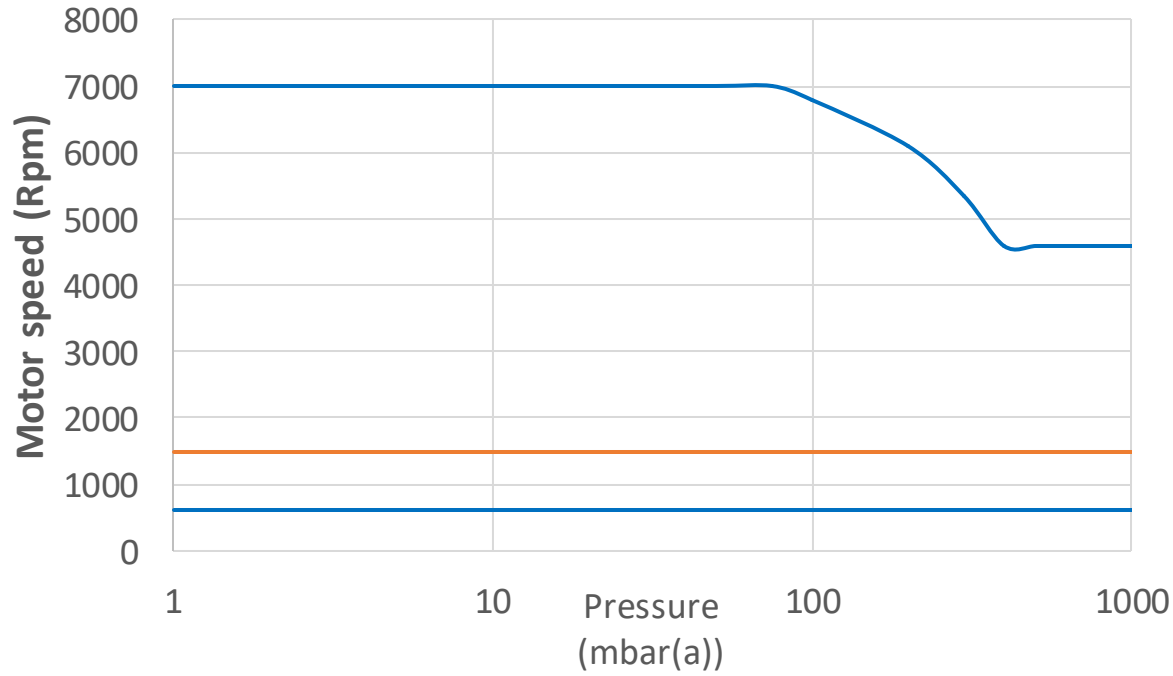
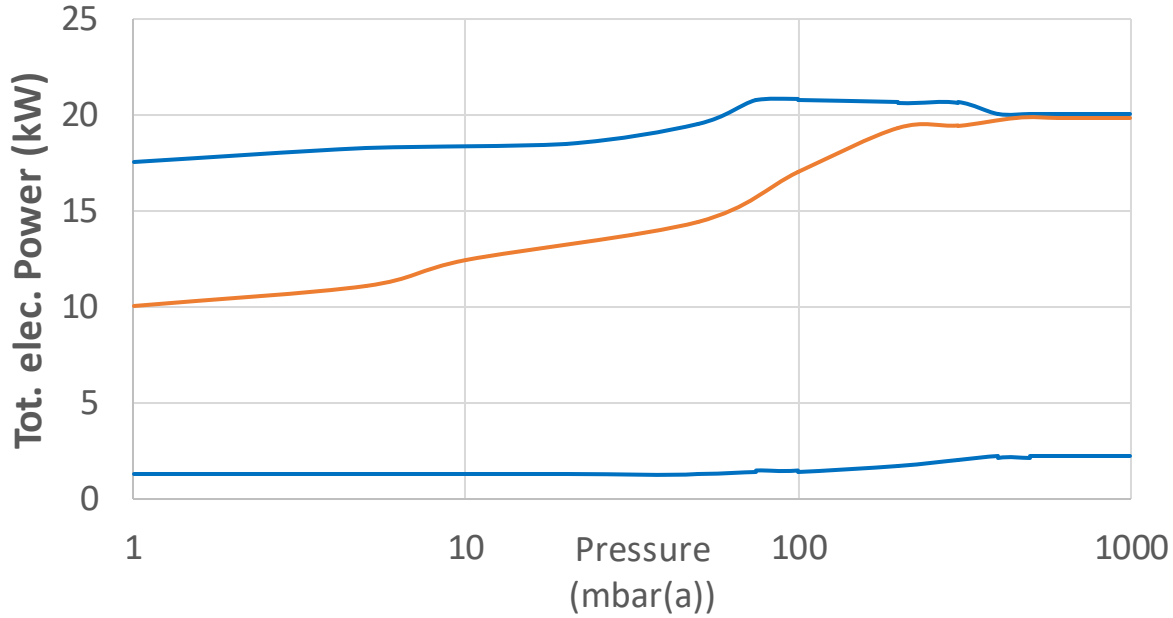

- The maximum rotor speed is depending of the inlet pressure.
- The max speed is reduced from atmosphere to 400mbar(a).
- More flow from 400-10mbar(a) compared to fixed speed machine with equivalent motor size.



EOSI BENEFITS & FEATURES

BENEFITS EOSI

- Energy efficiency
- Sustainable and environmental friendly
- Optimal reliability
- Easy, fast installation
- Wet and Quick versions



EOSI: HIGH ENERGY EFFICIENCY

AROUND 50% ENERGY SAVINGS

- Technology factor
- Limitation of the starting power
- Variable speed
- Selectable pressure (and accurate setpoint)

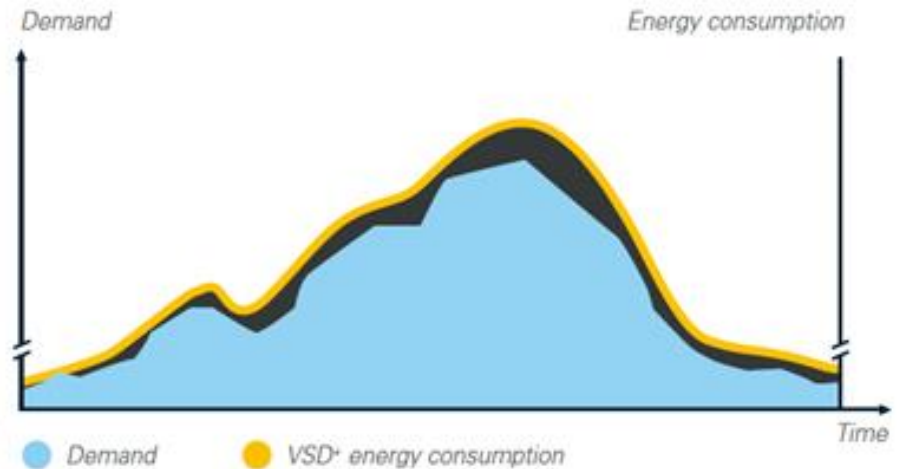
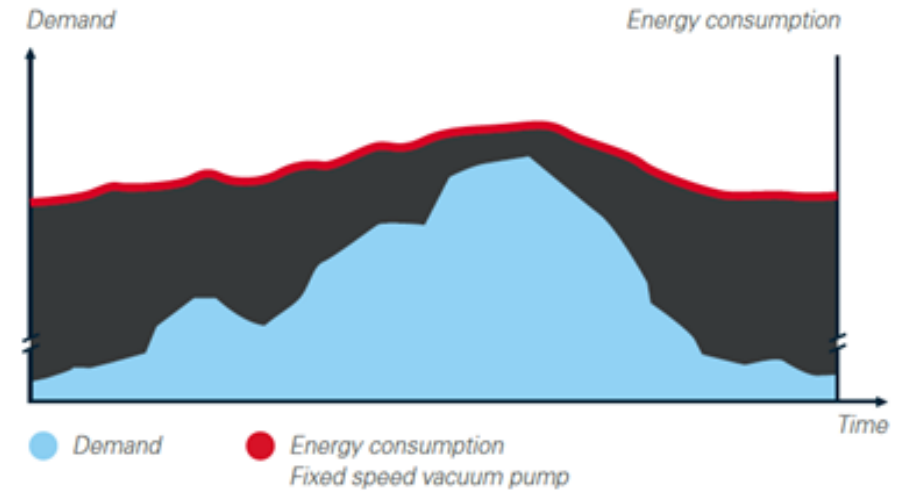

EFFICIENT OIL INJECTED SCREW TECHNOLOGY

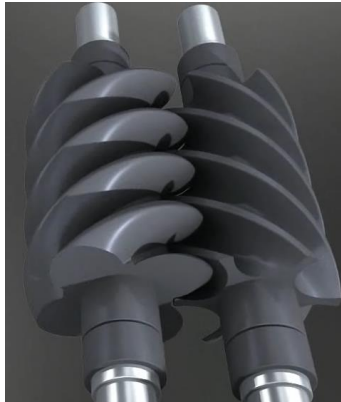
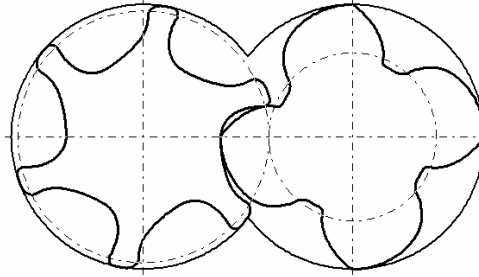

- Huge **efficiency** gains with state-of-the-art **screw technology**

- V111 : EOSi 350-900

- V146 : EOSi 1300-1900

- **IE3** – Premium efficiency motor

- Lafert : EOSi 350-900

- Siemens : EOSi 1300-1900

- **Direct drive**

➔ Outstanding performances – efficiency $\text{m}^3/\text{h}/\text{kW}$



ENERGY SAVINGS - IN 4 POINTS

Performances EOS 1900i at 150mbar(a)

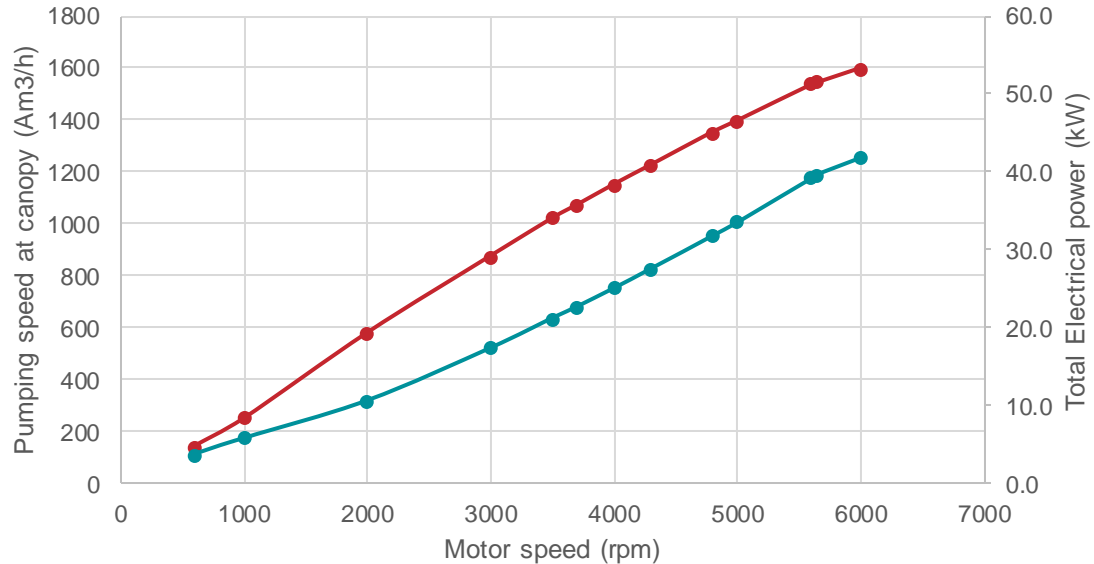

SER EOS 1900i at 150mbar(a)

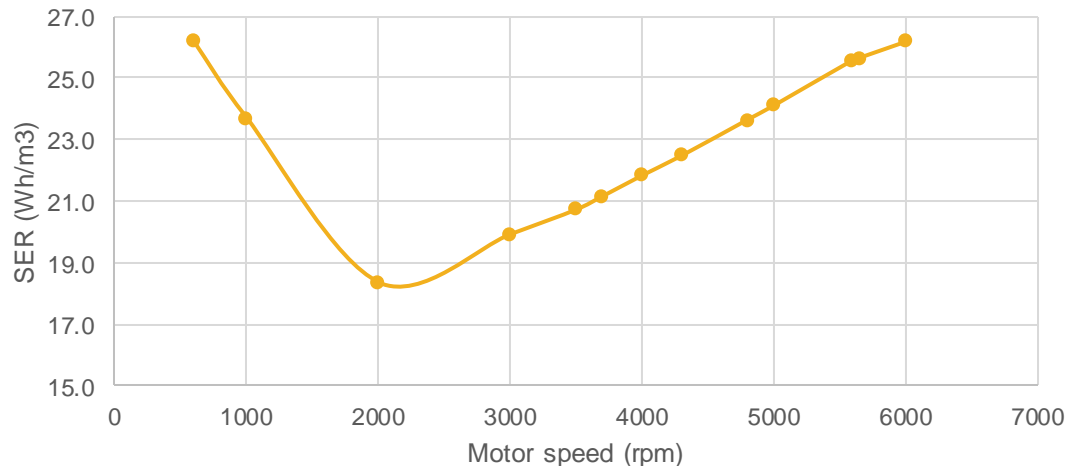

■ EFFICIENCY OF THE SCREW TECHNOLOGY

- The screw elements used in the EOSi has multiple decades of design refinement. The efficiency gain with oil injected screw technology offers a very low SER (Wh/m³).
- Operating pressure: 150 mbar(a)
- Pumping speed band: 143 - 1597 m³/h
- Total absorbed power: 3.8 – 41.8 kW
- SER: 18.4 – 26.2 Wh/m³

ENERGY SAVINGS - IN 4 POINTS

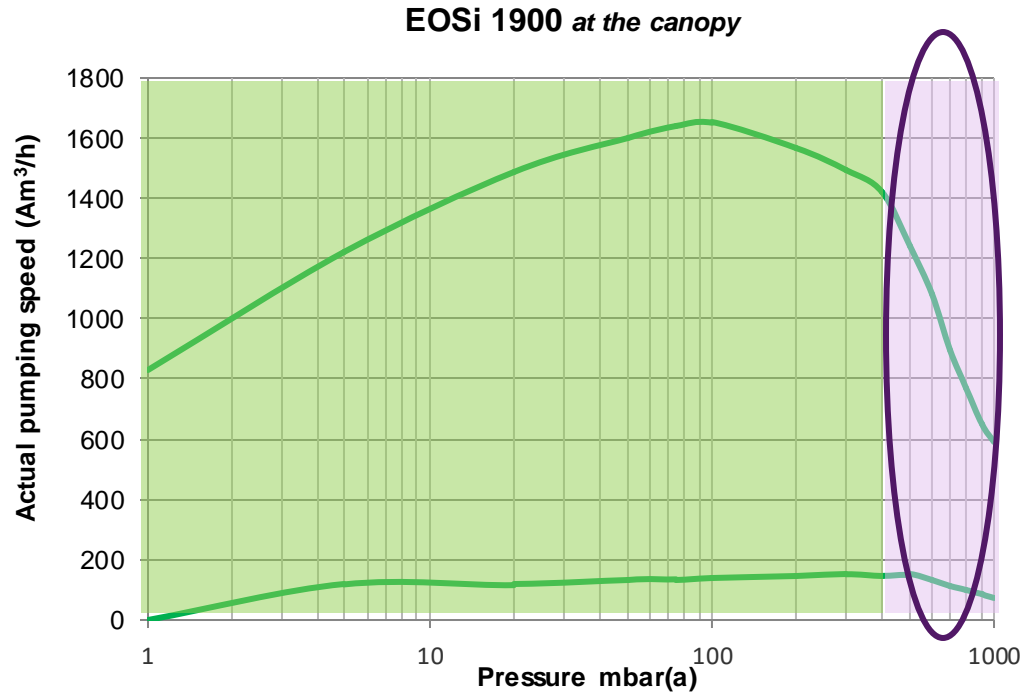

- **LIMITATION OF THE STARTING POWER**

- On start up the pumps are required to pump down from atmosphere. Between 1000mBar(a) and 400mBar(a) the EOSi **speed** is limited. If we limit the pump speed we limit the power. In addition the multifunction inlet valve is **modulating** (not fully open) and ensures a 400mBar(a) pressure in the screw element. This limits the flow and thus also power.
- Due to this smart design the EOSi can have a “one size” smaller installed motor.



SMART MODULATING INLET VALVE

- Innovative modulating inlet valve design
 - Modulating state : when the process pressure is in the range between 1000 and 400 mbar(a), pressure at the inlet of the pump element is constantly 400mbar(a) to control the flow at the start of pump down
 - ➔ lower power consumption
 - ➔ compact design oil separator vessel
 - ➔ no limitation on inlet pressure continuous operation at atmospheric pressure possible
 - Open state : when the process pressure is below 400mbar(a), the pressure at the inlet of the pump element is the same that the process pressure.
- Insure oil injection independent of the process pressure
 - ➔ eliminate oil pump circulation
- Acts as non return valve
 - ➔ protect the machine



ENERGY SAVINGS - IN 4 POINTS

■ VARIABLE SPEED DRIVE

- When the pressure decreases the EOSi will slow down, matching the demand and power requirement exactly.
- When the monitored pressure increases, the EOSi will speed up. The EOSi will run at 100% power until it reaches its set point. Once the set point is reached the EOSi can slow down to as low as 10% of its full package power.
- If there is no demand, the EOSi will simply stop. There is no limitations on number of starts and stops on the EOSi.

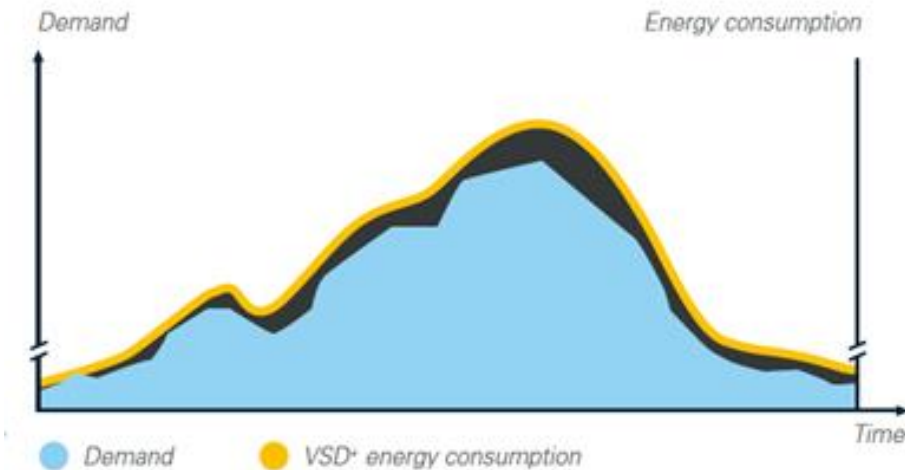
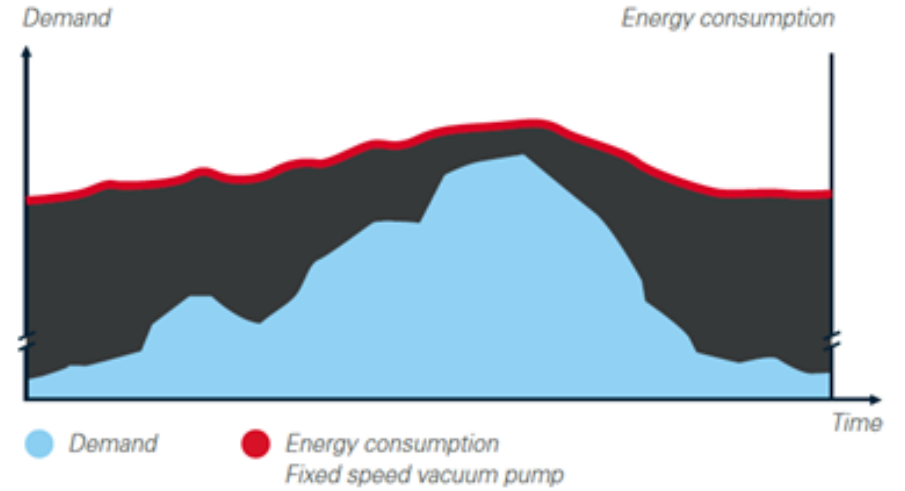
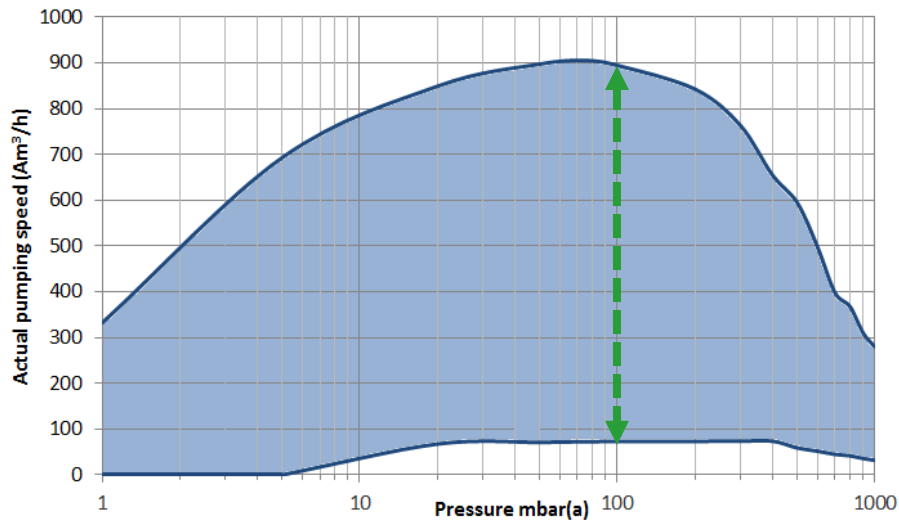

ENERGY SAVINGS - IN 4 POINTS

- **STABLE PRESSURE SETPOINT**

- The EOSi can operate at a user selectable vacuum level
- Smaller pressure band with several EOSi and ES system

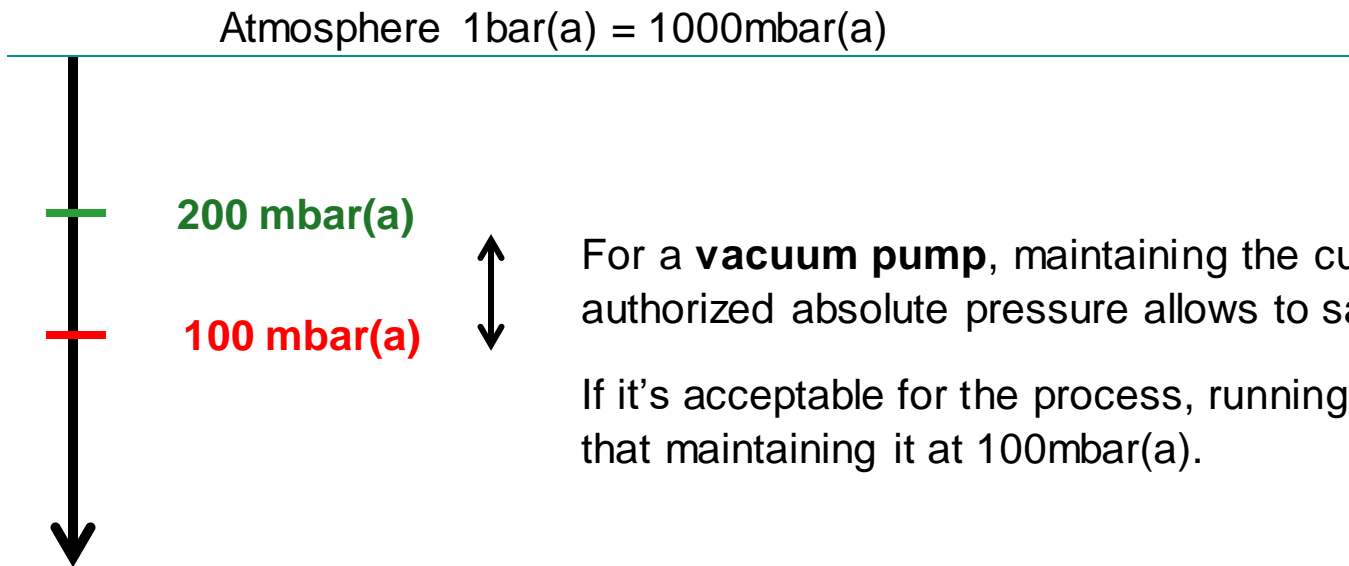

For a **vacuum pump**, maintaining the customer process at the maximum authorized absolute pressure allows to save energy.

If it's acceptable for the process, running at 200mbar(a) costs less energy that maintaining it at 100mbar(a).

MAXIMUM AUTHORIZED PRESSURE

- Example : a EOSi 585 runs at 90% max speed at **50mbar(a)**

→ Actual load demand = 479 m³/h at 50mbar(a)

→ Total power = 8.5 kW

But for the process, the *maximum pressure authorized is 75mbar(a)*.

Which flow does the process need at 75mbar(a) ?

$P \times V = \text{constant}$ → $50 \times 479 / 75 = 319$ m³/h at 75mbar(a)

→ Total power = 5.4 kW

→ **36% of energy savings !**

Conclusion :

- ✓ Working at lower pressure than needed is wasting energy!
- ✓ Optimum pressure = maximum authorized pressure

75 mbar(a)			50 mbar(a)		
Motor shaft speed	Pumping speed at the canopy	Total electrical power	Motor shaft speed	Pumping speed at the canopy	Total electrical power
rpm	Am ³ /h	kW	rpm	Am ³ /h	kW
600	72	1,2	600	71	1,2
1000	121	2,1	1000	119	1,9
2000	242	4,1	2000	237	3,9
2250	272	4,6	2250	267	4,3
2620	319	5,4	3000	364	5,9
3000	368	6,3	3500	421	7,2
3500	422	7,5	4000	479	8,5
4000	486	9,0	4500	523	10,1
4500	534	10,9			

BEST IN CLASS EFFICIENCY

- The EOSi delivers an average of 50% energy savings compared to traditional fixed speed vacuum pumps.
- This is achieved by:
 - Efficient technology
 - Start Up Current Limitation
 - VSD Matching
 - Selectable Set Point

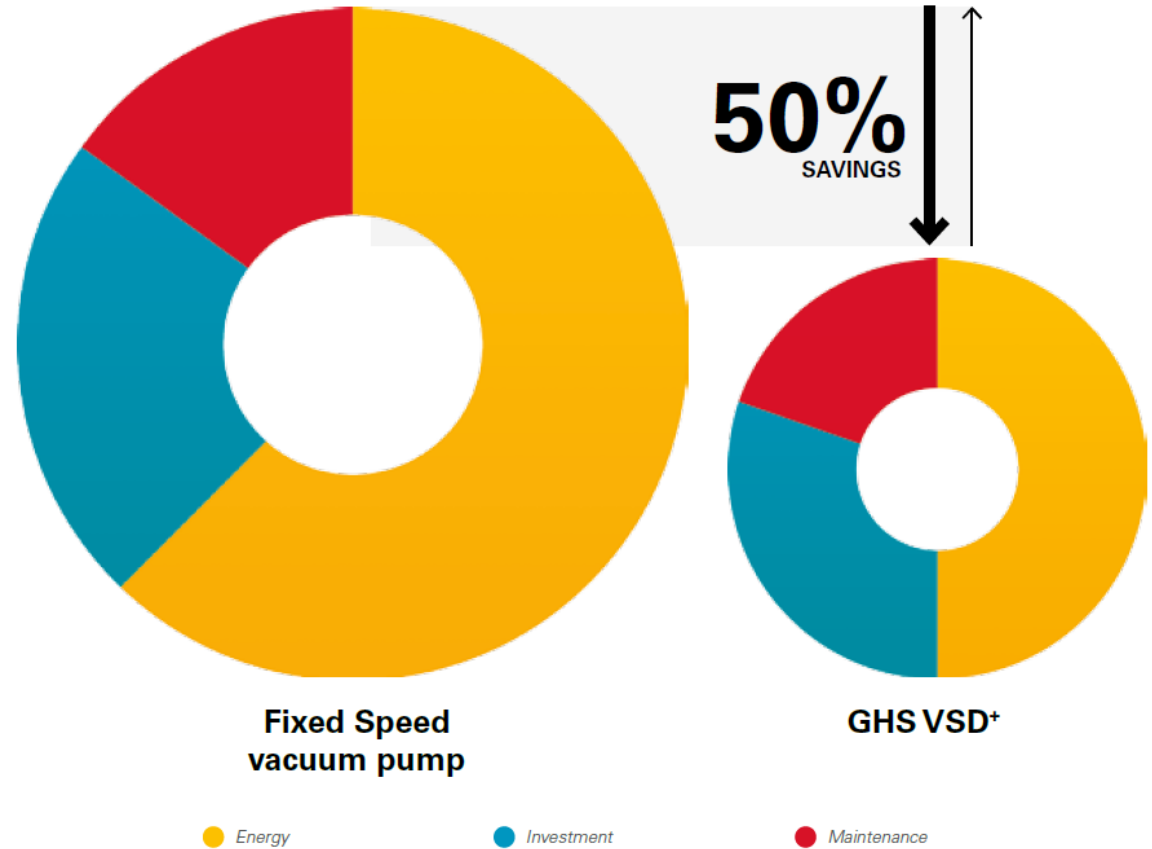



EOSi : SMART CONTROL AND MONITORING

AIRLOGIC

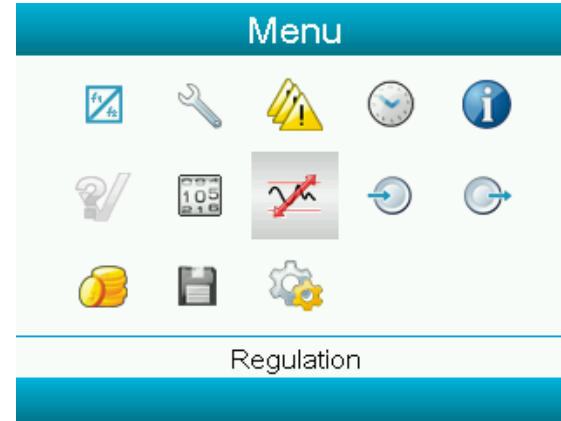
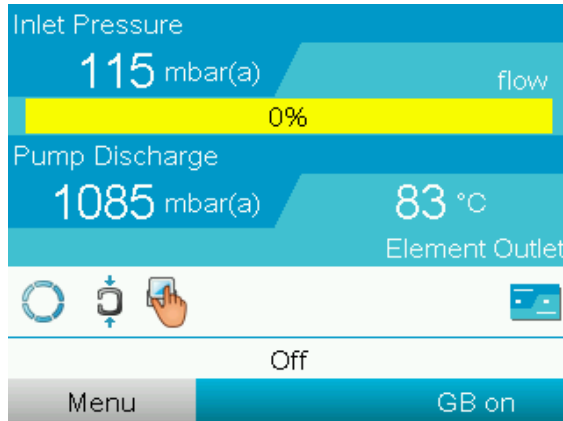

Regulation

Setpoint 1	50 mbar(a)
Indirect Stop Level 1	40 mbar(a)
Setpoint 2	250 mbar(a)
Indirect Stop Level 2	240 mbar(a)
	Modify

Counters

VSD 1-20% RPM	0%
VSD 20-40% RPM	85%
VSD 40-60% RPM	12%
VSD 60-80% RPM	1%

- All the functionalities of the Airlogic:
 - Runnings hours
 - Counters with speed range
 - Preventive maintenance
 -
- ➔ User-friendly controller



STANDARD PRESSURE TRANSDUCER

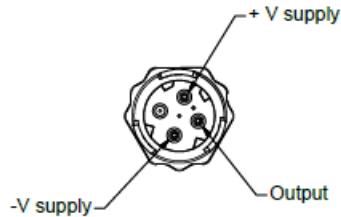
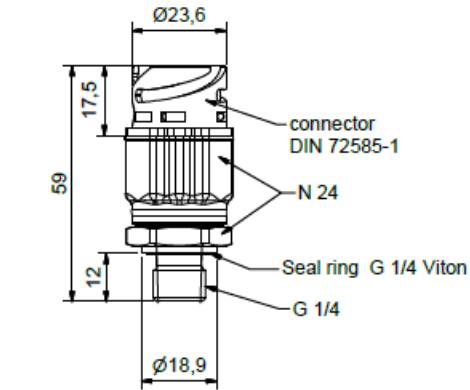
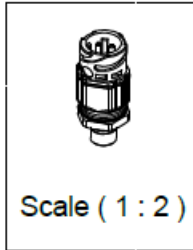

Technical data:

- Jumo Teile-number: 00613298
- Type: 401010/999-998-412-521-20-53/630 3
- Pressure range: 0...1000 mbar abs
0...14503,8 psi a
- Overpressure (min.): 1,5 bar abs
21,76 psi a
- Burst pressure: 3 bar abs
43,5 psi a
- Supply voltage (nominal): DC 5V ± 0,25V
- Output: 0,5...4,5V; 3-wire
- Accuracy 0.5...100mbar abs: ± 0.4% (4mbar) / Fs at 20...80°C
± 0.6% (6mbar) / Fs at 10...20°C
± 0.7% (7mbar) / Fs at 0...10°C
- Accuracy 100...1000mbar abs: 2% / Fs at 0...80°C
- Power consumption: max. 25mA
- Material: 1,4301
- Protection: IP 67
- Media and storage-temperature: -20...+100°C
- Specific feature: enlarged pressure-channel
- Media compatibility:
Oil (mineral-, screw compressor oil, PAO synthetic), water, air
- Torque for mating plug (based on DIN 72585-2):
locking: max. 1,2 Nm
extraction: min. 0,5 Nm - max. 1,2 Nm
- essential mating plug: Grote & Hartmann No. 17984 000 002
- Process-connection torque: max. 30Nm
- Markings to be applied to the housing:
see label 40101000A02Z001K009
- For more technical data see data-sheet-no. 40.1010
- Constructed for high vacuum strength
- Functional specification: 9820726208

- Below 100mbar(a), the accuracy is +/- 7mbar

Tolerances, if not indicated, according to:		General tolerances			
ATLAS COPCO STANDARD CLASS		1350K - m			
Name TRANSDUCER				Confidentiality Class acc. to 1102 K	
Material See Drawing				Confidential	
Treatment See Drawing				INV	
Scale 1:1		Family		Compare	
		Blank nr.		Replaces	
Version Drwg		Blank wt		Designation	
Kg		Kg		0,01 Kg	
Date		Date		Date	
28/03/2014		28/03/2014		28/03/2014	
Approved		Des checked.		Prod checked.	
Approved		Approved		Approved	
1625390276		1625390276		1625390276	

03	supplier type corrected	18/05/2015	1625390276		
Ed	Position	Modified from	Date	Int./Appd.	Parent 3D model
					Ed. Version 3D

HIGH ACCURATE PRESSURE TRANSDUCER (OPTION)

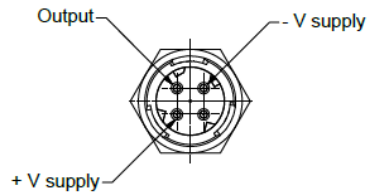
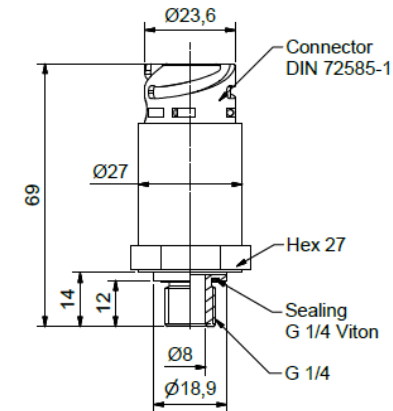
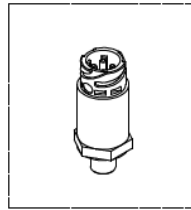

Technical data:

- Jumo Teile-number: 00643651
- Type: 401006/999-998-412-521-20-53/630
- Pressure range: 0...1000 mbar abs
0...14,50 psi a
- Overpressure (min.): 1,5 bar abs
21,76 psi a
- Burst pressure: 3 bar abs
43,5 psi a
- Supply voltage (nominal): DC 5V ± 0,25V
- Output: 0,5...4,5V; 3-wire
- Accuracy 0.5...10mbar abs: ± 0.2% (2mbar) / Fs at 0...10°C
- Accuracy 10...1000mbar abs: ±2% / Fs at 0...80°C
- Material: 1,4571, 1,4435
- Protection: IP 67
- Media and storage-temperature: -20...+100°C
- Constructed for high vacuum strength
- Specific feature: enlarged pressure-channel
produced and calibrated in research laboratory
- Media compatibility:
Oil (mineral-, screw compressor oil, PAO synthetic), water, air
- Torque for mating plug (based on DIN 72585-2):
locking: max. 1,2 Nm
extraction: min. 0,5 Nm - max. 1,2 Nm
- Essential mating plug: Grote & Hartmann No. 17984 000 002
- Process-connection torque: max. 30Nm
- Markings to be applied to the housing:
see label 40100600A02Z001K009
- For more technical data see data-sheet-no. 401006

- For application where the vacuum level is equal or below 10 mbar(a) : accuracy +/-2mbar.

Tolerances, if not indicated, according to:		General tolerances			
ATLAS COPCO STANDARD CLASS		1350K - m			
Name	TRANSDUCER			Confidentiality Class acc. to 1102 K	
Material	See drawing			Confidential	
Treatment	See Drawing			INV	
	Scale	1:1	Family	Compare	Drawing owner
	Drawn by	INEnic	Blank nr.	Replaces	API
Drawing format	Blank wt	kg	Fin wt.	0,000 kg	Designation
SRIS	A3				Sheet 1 / 1
Approved	Des checked.	Prod checked.	Approved.	Date 26/03/2014	1625390487

00			30/8/2015		1625390487		
Ed	Position	Modified from	Date	Intr./Appd.	Parent 3D model	Edition 3D	

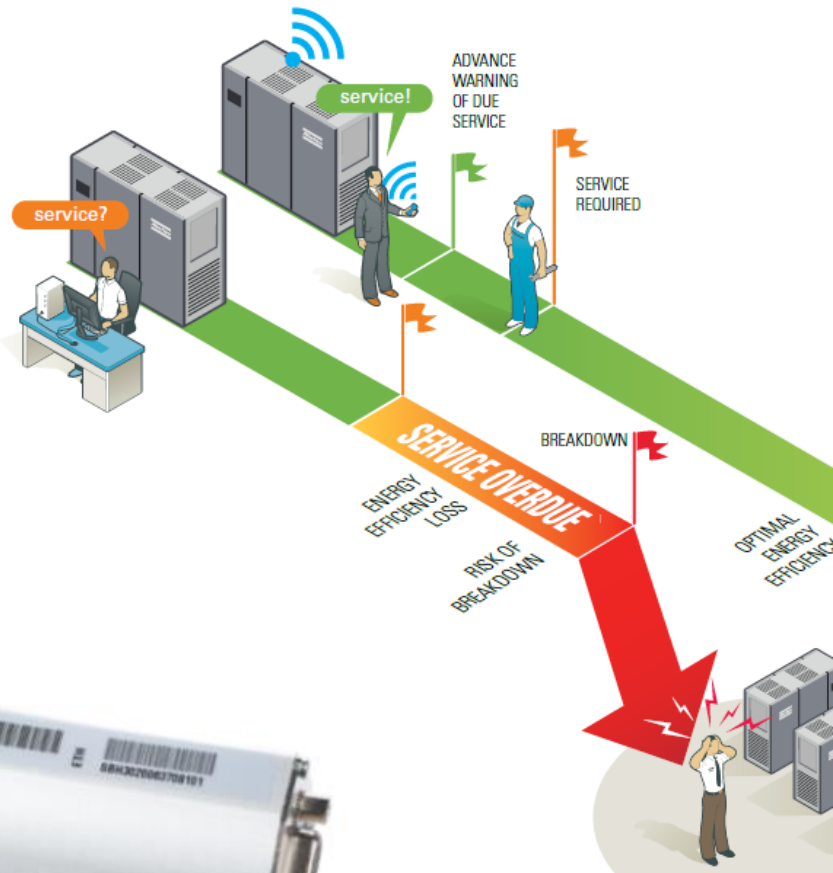

Helping to detect service needs, developing problems and potential for optimization and energy savings !

■ ICONS SERVICE

- Remote information of your machines status for Atlas Copco

■ ICONS UPTIME

- Keep you effortlessly informed of pump performance and maintenance requirements
- SMS/email notification (service, failures, warnings)

■ ICONS ENERGY

- Energy savings report provided monthly





EOSi: ENVIRONMENTAL FRIENDLY

OPTIMAL OIL RETENTION

- Market-leading oil retention for optimal exhausted air quality: innovative and patented design
 - Cyclonic air – oil separator vessel, projecting 95% of the oil particles on the separator wall
 - Vertical oil separator elements – oil retention < 3 mg/m³ even under the greatest load
- Separator elements never overloaded thanks to the inlet modulating valve which limits the flow at the start pump down

	Number OSE
EOSi350	3
EOSi585	4
EOSi730	5
EOSi900	6
EOSi 1300	8
EOSi 1600	10
EOSi 1900	12

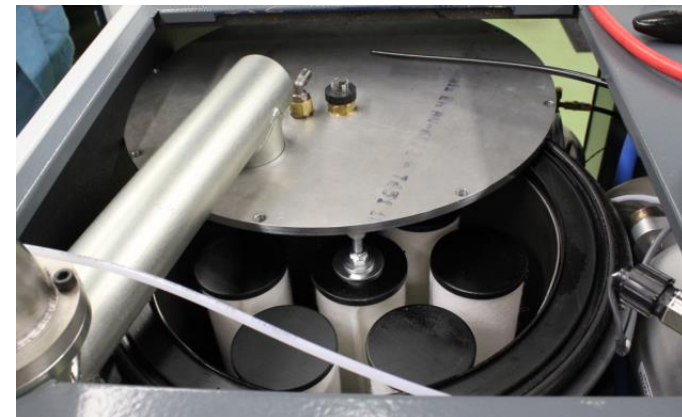

HALF THE NOISE LEVEL

- Half the noise level of comparable technologies :
 - Canopy
 - Variable speed, lower noise at low speeds
- Silent components as the cooling fan

EOS 350i	51-65 dB(A)
EOS 585i	51-68 dB(A)
EOS 730i	51-73 dB(A)
EOS 900i	51-76 dB(A)
EOS 1300i	65-75 dB(A)
EOS 1600i	65-79 dB(A)
EOS 1900i	65-80 dB(A)

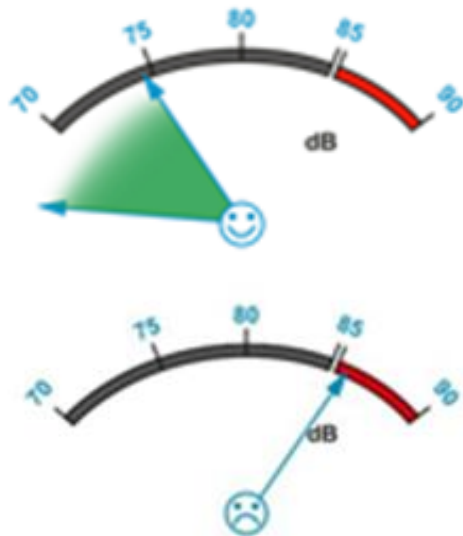



EOSi: OPTIMAL RELIABILITY AND SUSTAINABILITY

SUSTAINABILITY, LONG LASTING COMPONENTS

- Screw element life : overhaul at 48 000hrs for normal applications
- Oil separator elements never overloaded and longer life : 4000hrs for normal applications
- Long life oil filter : 4000hrs for normal applications
- Resistant air inlet filter with polyester element

	Oil quantity (synthetic oil)
EOS 350-900i	16 L
EOS 1300-1900i	40 L

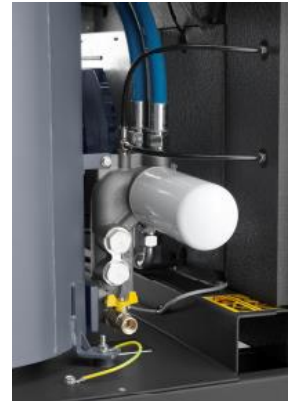

COOLING AIR – HOT & COOL ZONES CANOPY

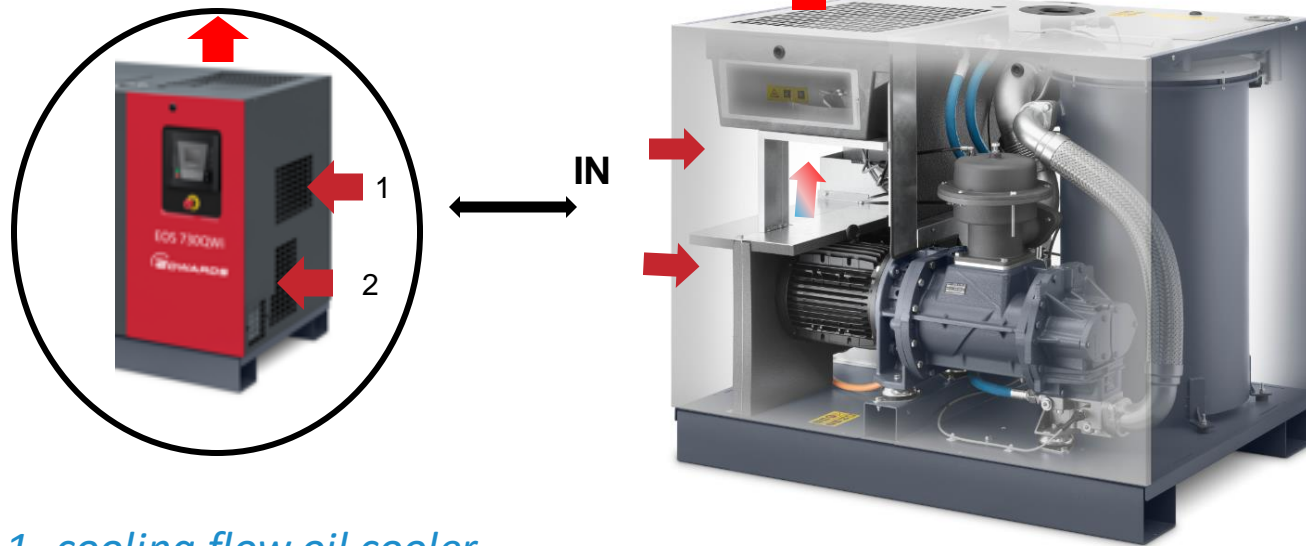

1- cooling flow oil cooler

2- cooling flow motor and inverter

Results in canopy with
hot/cool zones



Isolate all heat producing and temperature critical components (motor, oil separator, element) from all other components.

➔ Long life electronic components

INVERTER IMPERIUM ON EOS 1300-1900i



- Inverter designed by Atlas Copco
 - **Simple** : exactly what a VSD vacuum pump needs, no more.
 - **Robust, compact and reliable** :
 - no needless digital outputs and developed to work with AIRlogic MK5
 - Can operate in harsh conditions : until 50°C ambient, dusty applications, IP5X enclosure protection

PROTECTION

- Temperature sensor at the outlet of the element
 - Fan control on this temperature sensor
- Pressure switch connected to the oil separator vessel housing
 - Switch off the machine if the pressure in the oil separator is above 1.5 bar(a)
- Temperature switch connected at the top of the oil separator
 - Switch off the machine if the temperature is above 120°C



Temperature sensor

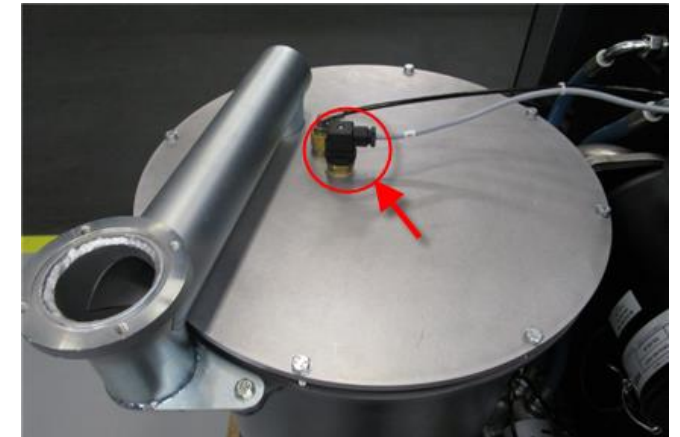

Temperature switch



EOSi : EASY FAST INSTALLATION

PLUG & PLAY UNIT

- Inlet, outlet and cable entry at the top
- Machine provided with the inlet filter, the cubicle, canopy, controller



Machine type	Dimensions L × w × h
EOS 350-900i	1.3×0.9×1.1 m
EOS 1300-1900i	1.58×1.59×1.47 m

THREADED FLANGE CONNECTION

- In option on the EOS 350-900i :
 - 0000086552 : G-threaded inlet
 - 0000086554 : G-threaded outlet
 - 0000086553 : NPT-threaded inlet
 - 0000086555 : NPT-threaded outlet

- In standard for the inlet of the EOS 1300-1900i and in option for the outlet :
 - 0000086754 : G-threaded outlet
 - 0000086755 : NPT-threaded outlet

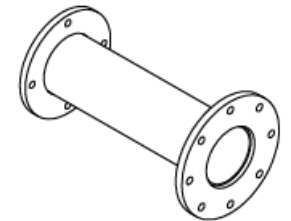
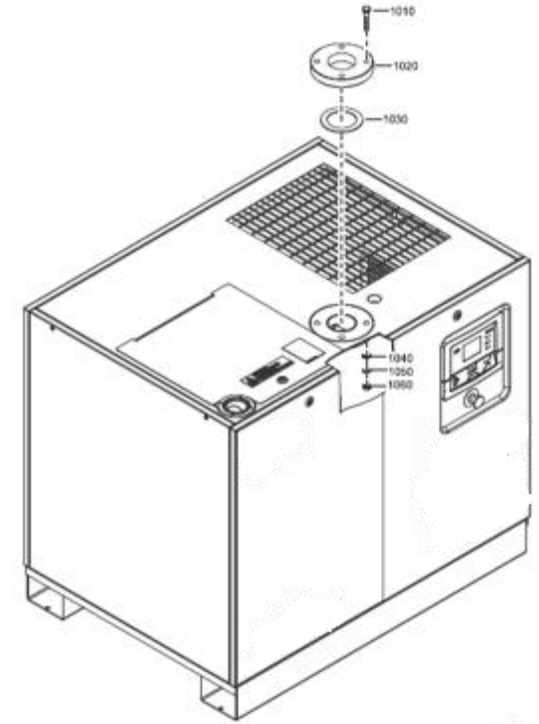



QUICK VERSION

QUICK VERSION

- For cycling application
 - Bigger motor and braking resistor for the inverter for high dynamic loads.
 - Highest minimum speed curve
 - Different program settings on the PI control: lower proportional band and integration time
- ➔ Reduce cycle time and increase process productivity

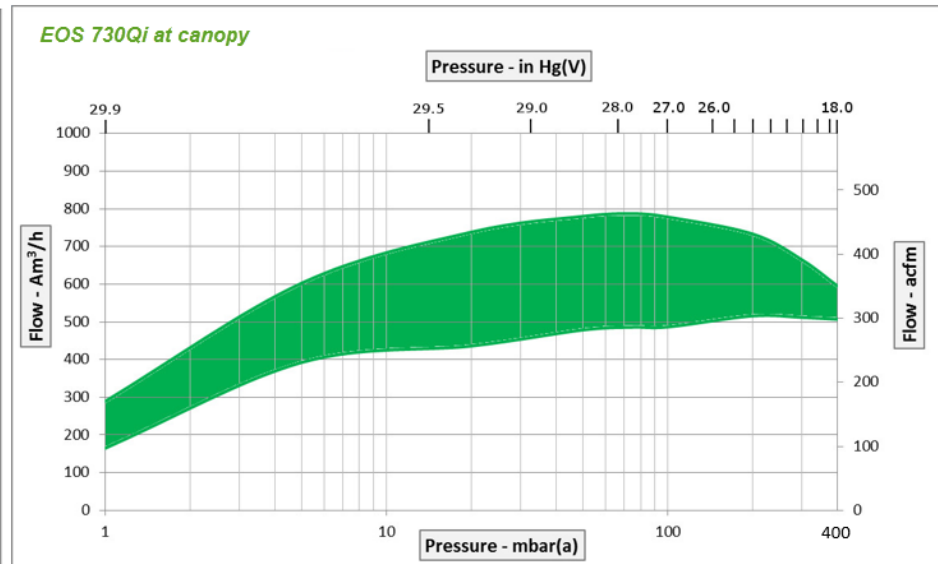
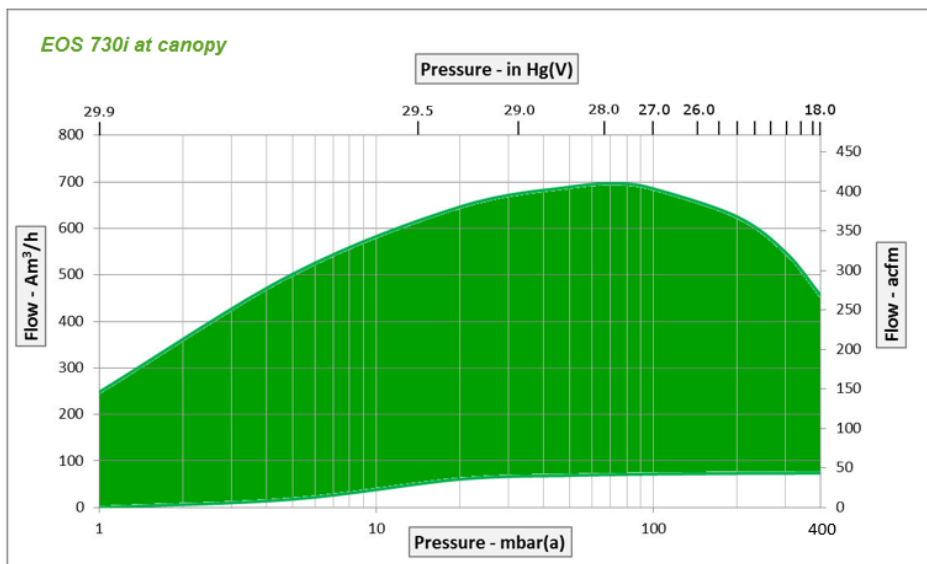

PI SETTINGS

- The Elektronikon uses a PI-controller to adapt its flow (motor speed) to achieve the pressure setpoint.
- The **proportional band** multiplies the error between the actual pressure and the setpoint. The proportional band mainly has effect on the responsiveness of the system. Low proportional bands have better responsiveness, but too low proportional bands may cause pressure oscillations.
- The **integration time** integrates the error between the actual pressure and the setpoint over time. So the longer the error is present, the more the speed will increase. The integration time has mainly effect on the steady state error, e.g. pressure setpoint is 50 mbar, but the pressure does not go below 60 mBar. Too low integration times may cause instable behavior.

Range: $5\% \leq \text{Proportional band} \leq 15\%$

Initial value: **Proportional band = 10%**

Range: $0.5 \text{ seconds} \leq \text{Integration time} \leq 10 \text{ seconds}$

Initial value: **Integration time = 5 seconds**

Regulation	
Digital Pressure Band Selection	Off
Maximum Speed Factor	100 %
Proportional Band	10.0 %
Integration Time	5.0 s
Modify	

For **Quick Version**, **Proportional band = 5%** and **Integration time = 0.5s**

OTHERS SETTINGS FOR QUICK VERSION

- Runtime at minimum pressure :
 - To maintain a very dynamic pump, the runtime at minimum pressure can be set. This is a settable delay when the pump reach its Stoplevel before going to Standby or Purge. It will keep the pump running, inlet valve closed, for a next cycle without stopping
 - ➔ Set a runtime at minimum pressure enough high to span the time between 2 cycles

Range: 0 seconds ≤ **Runtime at minimum pressure** ≤ 180 seconds

Initial value: **Runtime at minimum pressure** = 30 seconds

NEW QUICK PROGRAM (AVAILABLE SOON!)

- **Goal** : achieve a faster pump down time when vacuum is required and save more energy when vacuum is not required
- **Principle** : thanks to a relay/switch open/closed, put the EOS Q in different modes :
 - Switch closed (phase 1) → pump is forced to maximum speed, *like with the CTS commissioning program to test the ultimate vacuum*
 - Switch open (phase 2) → pump regulates on pressure set point control

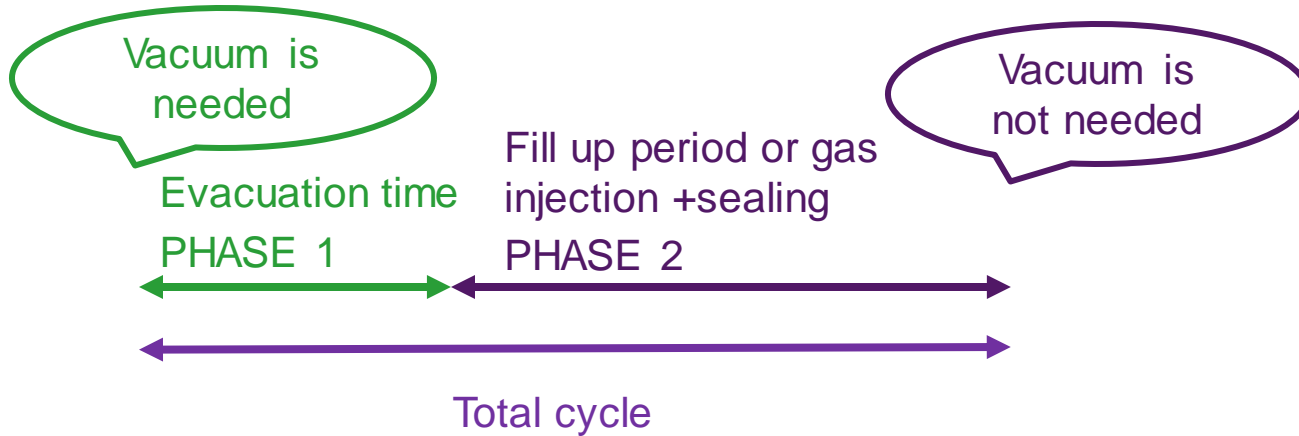

NEW QUICK PROGRAM (AVAILABLE SOON!)

XML Config General Settings Special Alarms Counters Internal Data Service Plan Week Timers

IP Settings
Machine Definition
Display Preferences
Control Timers
Bar Info Mainscreens
ARAVE
Start Check Timer
CCM Change Options
CCM4b Communication Timeout
Passwords
Saved Data
Temperature Control
Inlet Control Valve
Oil Drain
Gas Ballast
Audit Data Settings
Audit Data Curves
Analog IO Function
Converters
Dig IO Functions
ES
Fans
Setpoint And Speed Control
Setpoint Control
VSD Vacuum Speed Setup
 GHS350 VSD+ [76]
 GHS585 VSD+ [74]
 GHS730 VSD+ [67]
 GHS900 VSD+ [68]
 GHS350 VSD+ Turbo [73]
 GHS585 VSD+ Turbo [75]
 GHS730 VSD+ Turbo [72]
 GHS1300 VSD+ [84]
 GHS1600 VSD+ [85]
 GHS1900 VSD+ [93]
 GHS1300 VSD+ Turbo [95]
 GHS1600 VSD+ Turbo [94]
VSD Vacuum Regulation
Digital Pressure Setpoint Selection
External Speed Control
 Maximum RPM Line Influence
 Minimum RPM Line Influence
 Temperature Speed Adjustment
 Temperature Speed Adjustment 2
 Current Speed Adjustment
 Current Speed Adjustment PI

Features/Options
0
MODEL
GHS900VP15 gen. 1

Dataset
Find Create Report Help Screenshot Compare to

Speeds used for VSD Vacuum Regulation.

Filter Maximum Speed

Up/Down line Maximum N2:	7000	rpm
Up/Down line Minimum N1:	4600	rpm
Pressure Down Line P2:	400	mBar
Pressure Down Line P1:	75	mBar
Pressure Up Line P2:	390	mBar
Pressure Up Line P1:	65	mBar

Filter Minimum Speed

Minimum Line P2:	0	mBar
Minimum Line N2:	600	rpm
Minimum Line P1:	0	mBar
Minimum Line N1:	600	rpm

Specific Speeds

Pre Run RPM:	1500	rpm
Modulation Speed:	3500	rpm
Auto RPM Offset:	40	rpm
Pre Purge Speed:	7000	rpm
Post Purge Speed:	1000	rpm

- To save more energy, you can set the minimum speed at 600rpm via Modi5 (at the commissioning)

➔ The pump will consume almost nothing when vacuum is not needed



WET VERSION

WET VERSION

- To avoid condensation :
 - Keep the oil hotter thanks to a 87°C thermostatic valve (instead of a 83°C thermostatic valve)
 - Purge Time :
 - Manual purge : to activate the purge mode : button on the screen, digital input or via week timer
 - Pre-purge : start to open the inlet valve of the pump after the oil has reached 80°C (pre-purge program) → time or temperature
 - Post-purge the oil during few minutes – inlet valve closed – before stopping the pump (post-purge program). During the Post-Purge the Airlogic will adapt the motor speed to achieve an element outlet temperature between 97°C and 102°C to evaporate all accumulated water → time
 - Gas ballast open

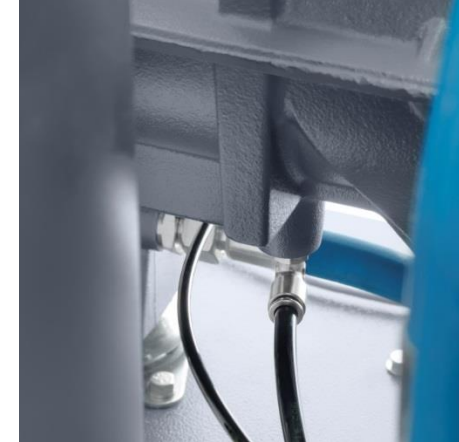

Regulation	
Purge	Activated
Pre Purge Time	15 min
Post Purge Time	30 min
Manual Purge Time	30 min
Modify	

WET VERSION

- Maintain all the water vapors under vapor state
- Possibility to drain if condensates from the exhaust pipe



Horizontal pipe then drip leg



ENERGY RECOVERY

EOS1300-1900i

ENERGY RECOVERY

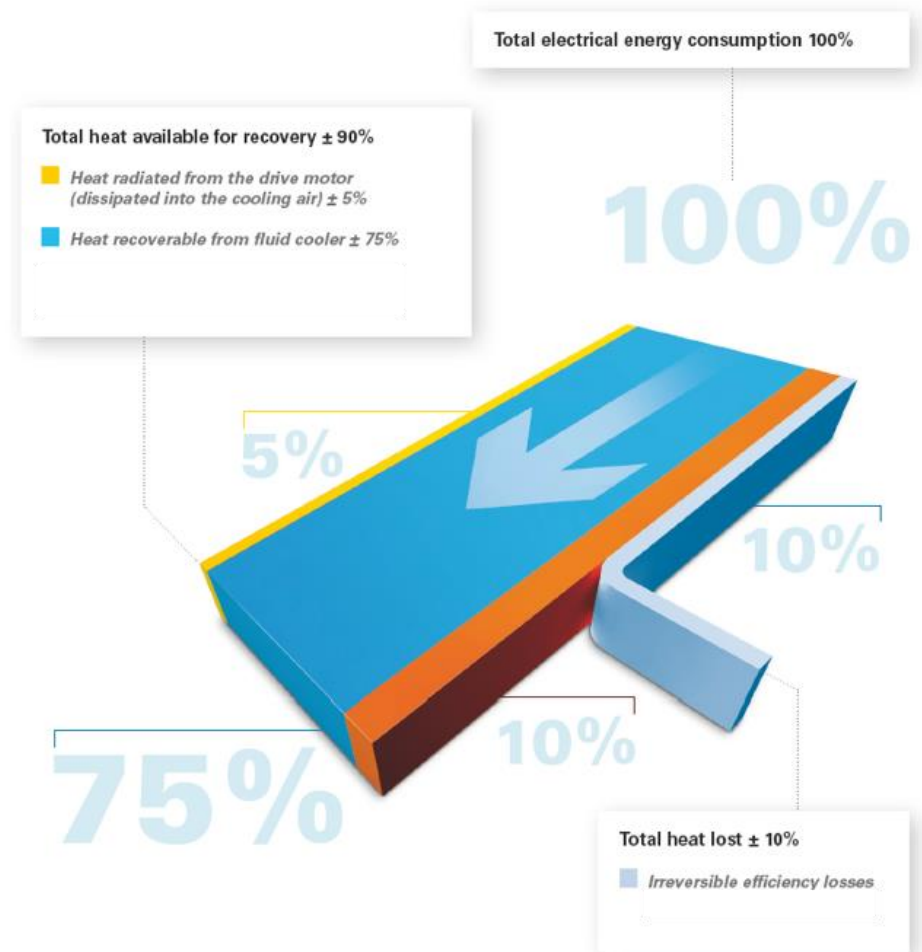
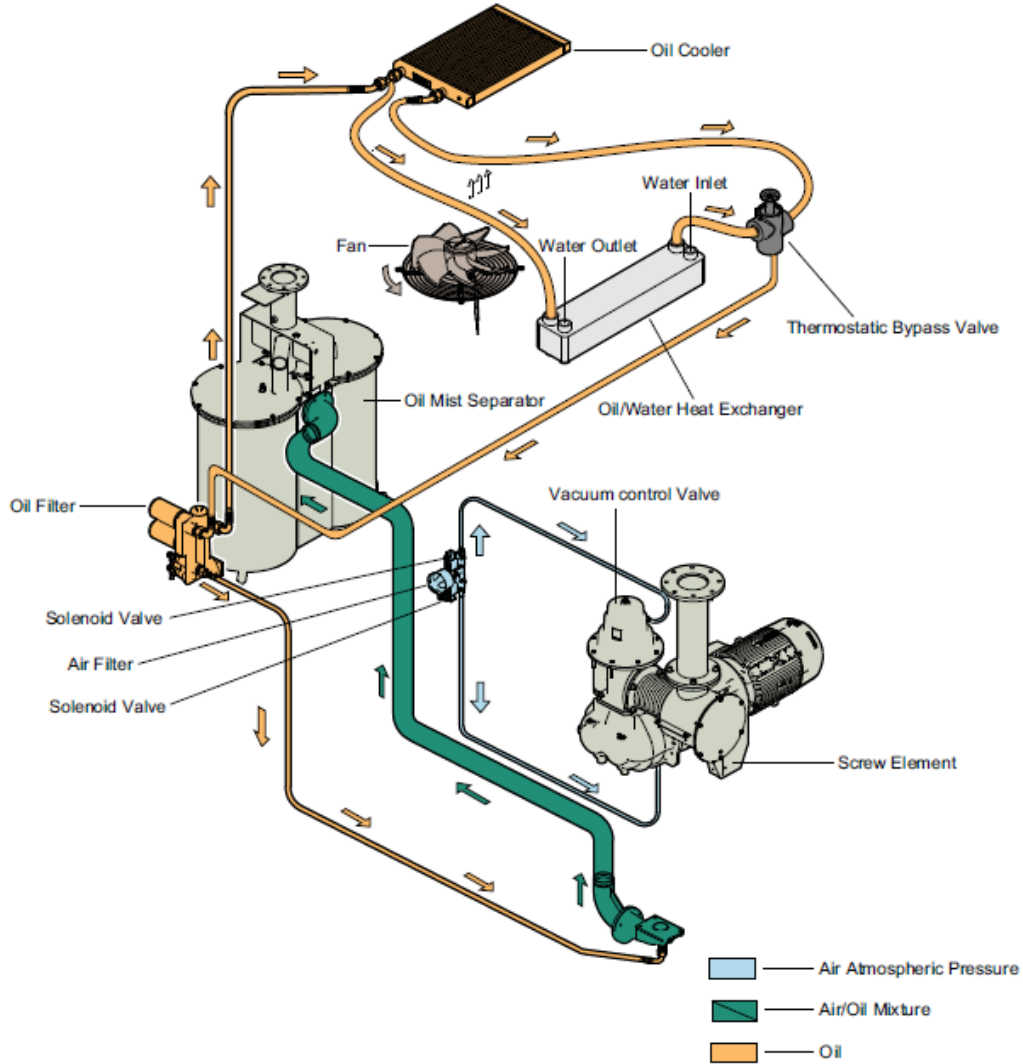

- Allowing to recover up to 70%-80% of the total power consumption
- Helping to fulfill the energy & environmental commitments according to ISO 50001/14001

ENERGY RECOVERY

Data for low temperature rise/high water flow systems

Parameter	Unit	EOS 1300i		EOS 1600i		EOS 1900i	
		5 mbar	400 mbar	5 mbar	400 mbar	5 mbar	400 mbar
Recoverable energy	kW	22.9	15.3	26.9	18.0	31.2	20.8
Recoverable energy	hp	30.7	20.5	36.1	24.1	41.8	27.9
Water flow	l/min	33	22	39	26	45	30
Water flow	cfm	1.17	0.78	1.38	0.92	1.59	1.06
Temperature at inlet	°C	40	40	40	40	40	40
Temperature at inlet	°F	104	104	104	104	104	104
Temperature at outlet	°C	50	50	50	50	50	50
Temperature at outlet	°F	122	122	122	122	122	122
Pressure drop over ER assembly	bar	0.090	0.044	0.121	0.059	0.159	0.076
Pressure drop over ER assembly	psig	0.131	0.065	0.176	0.085	0.231	0.110

Data for high temperature rise/low water flow systems

Parameter	Unit	EOS 1300i		EOS 1600i		EOS 1900i	
		5 mbar	400 mbar	5 mbar	400 mbar	5 mbar	400 mbar
Recoverable energy	kW	23.4	15.6	27.4	18.3	31.7	21.4
Recoverable energy	hp	31.4	20.9	36.7	24.5	42.5	28.6
Water flow	l/min	17	11	20	13	23	16
Water flow	cfm	0.6	0.39	0.71	0.46	0.81	0.57
Temperature at inlet	°C	20	20	20	20	20	20
Temperature at inlet	°F	68	68	68	68	68	68
Temperature at outlet	°C	40	40	40	40	40	40
Temperature at outlet	°F	104	104	104	104	104	104
Pressure drop over ER assembly	bar	0.029	0.016	0.038	0.020	0.048	0.025
Pressure drop over ER assembly	psig	0.043	0.024	0.055	0.029	0.070	0.037



Recovered energy (kW) = 4.2 × water flow (l/s) × water temperature rise (°C)

The logo features a red curved line that starts on the left, arches over a black arrow pointing to the right, and ends on the right. The word "EDWARDS" is written in a bold, red, italicized sans-serif font, positioned to the right of the graphic.

EDWARDS